

Instruction Manual

optoCONTROL 2500

MICRO-EPSILON
Eltrotec GmbH
Heinkelstraße 2

73066 Uhingen / Germany

Tel. +49 (0) 7161 / 98872-300

Fax +49 (0) 7161 / 98872-303

eltrotec@micro-epsilon.de

www.micro-epsilon.com

Certified in compliance with DIN EN ISO 9001: 2008

From serial number 1007379:

Software version V1020

Contents

1.	Safety	5
1.1	Symbols Used	5
1.2	Warnings.....	5
1.3	Notes on CE Identification.....	6
1.4	Proper Use.....	6
1.5	Proper Environment	6
2.	Laser Class	7
3.	Functional Principle, Technical Data	8
3.1	Measurement Principle.....	8
3.2	Structure of a Complete Measurement System.....	8
3.3	Controller	9
3.3.1	Front View of the Controller.....	9
3.3.2	Rear View of the Controller.....	9
3.4	Operating Modes.....	10
3.5	Technical Data	11
3.6	Block Diagram	12
3.7	Analog Output	13
3.8	Zero-Setting Input.....	13
3.9	Synchronization.....	13
3.10	Error Output.....	13
3.11	Laser Switch-off	13
4.	Delivery	14
4.1	Supplied Items.....	14
4.2	Storage	14
5.	Installation and Mounting	14
5.1	Precautions.....	14
5.2	Mounting the Sensor Unit.....	14
5.3	Mounting the Controller.....	17
5.4	Supply Voltage	17
5.5	Connecting of Terminal Equipment.....	18
5.5.1	Connectivity Overview	18
5.5.2	PCI-Interface Card IF2008.....	19
5.5.3	Universal Controller CSP2008.....	21
5.5.4	Connecting an Analog Terminal Device	21
5.5.5	RS232 and RS422	22
5.6	Switching Outputs	24
5.7	Switching Inputs	24
5.8	Synchronization Input.....	24
6.	Operation	25
6.1	Putting into Operation	25
6.2	Menu Structure	25
6.3	Operating the System.....	26
6.3.1	Key Functions	26
6.3.2	Display	26
6.3.3	Main Menu	26
6.3.4	Options	27
6.3.5	Video Signal.....	27
6.3.6	Select Measurement Program	28
6.3.7	Edit Measurement Program (User-Specific Programs)	29
6.3.7.1	Zero-Setting Function.....	30
6.3.7.2	Mastering	30
6.3.7.3	Measurement Programs Segment and 2-Segment.....	31
6.3.7.4	Display Scaling.....	31
6.3.7.5	Limit Monitoring	32
6.3.7.6	Averaging.....	33

6.4	Analog Output	33
6.4.1	Setup	33
6.4.2	Measurement Conversion	33
6.4.3	Error Handling	34
6.5	Synchronization of optoCONTROLS	35
6.6	Timing	36
6.7	Error Effects	36
6.7.1	Extraneous Light.....	36
6.7.2	Effects on the Light Beam	37
6.7.3	Contamination	38
6.7.4	Transparent Targets.....	38
7.	Digital Interface	39
7.1	Interface Parameters	39
7.2	Data Conversion.....	39
7.3	Control Commands	40
7.4	Commands	41
7.4.1	Overview	41
7.4.2	Information Command	42
7.4.3	Start Command	42
7.4.4	Stop Command	42
7.4.5	Reset Command.....	43
7.4.6	Change the Measurement Program.....	43
7.4.7	Change Edges (Segment and 2-Segment Programs)	44
7.4.8	Read Out Min / Max Values	44
7.4.9	Read Out Min / Max Values Followed by Reset.....	44
7.4.10	Read Option Data.....	45
7.4.11	Write Option Data	46
7.4.12	Save Option Data	47
7.4.13	Read Measurement Program Data	48
7.4.14	Write Measurement Program Data.....	49
7.4.15	Save Measurement Program Data	50
7.4.16	Error Responses.....	50
8.	Accessories	51
9.	Warranty.....	51
10.	Service, Repair	52
11.	Decommissioning, Disposal	52
12.	Annex	53
12.1	Operating Menu.....	53
12.1.1	Initialization and Operation in the Measurement Mode	53
12.1.2	Dialog and Procedure for Saving	54
12.1.3	Option (General Settings)	55
12.1.4	Selecting the Measurement Program	56
12.1.5	Editing the Measurement Program	57
12.1.6	Generate a Segment Program	58
12.2	Default Procedure.....	59

1. Safety

The operation of the system requires knowledge of the operating manual.

1.1 Symbols Used

In this operating manual the following designations are used:



Indicates a hazardous situation which, if not avoided, may result in minor or moderate injury.



Indicates a situation which, if not avoided, may lead to property damage.



Indicates an user action.



Indicates an user tip.

1.2 Warnings



Connect the power supply and the display / output device according to the safety regulations for electrical operating equipment.

- > Danger of injury.
- > Damage to laser / receiver or the controller.



Avoid shock and knocks on the laser / receiver and the controller.

- > Damage to laser / receiver or the controller.

Supply voltage must not exceed specified limits

- > Damage to laser / receiver or the controller.

Avoid damage (scratches) to the protective windows of the laser and receiver through unsuitable cleaning methods or cleaning solvents.

- > Inaccurate, erroneous measurements.

Do not touch the protective windows of the laser and receiver with the fingers. Wipe off any finger prints immediately.

- > Inaccurate, erroneous measurements.

Do not pug or unplug the connectors on the laser or receiver with the controller switched on.

- > Damage to laser / receiver or the controller.

Protect cables from damage.

- > Failure of the measurement device.

Avoid permanent action of dust or splashed water on the measurement channel. Blow off or use protective housing.

- > Damage to laser / receiver or the controller.

1.3 Notes on CE Identification

The following applies to the optoCONTROL 2500 measurement system:

- EU directive 2004/108/EC
- EU directive 2011/65/EC, "RoHS" category 9

Products which carry the CE mark satisfy the requirements of the quoted EU directives and the European standards (EN) listed therein. The EC declaration of conformity is kept available according to EC regulation, article 10 by the authorities responsible at

MICRO-EPSILON Eltrotec GmbH
Heinkelstraße 2
73066 Uhingen / Germany

The measuring system is designed for use in industry and satisfies the requirements.

1.4 Proper Use

The optoCONTROL 2500 is designed for applications in the industrial field.

It is employed for

- displacement, distance, edge and offset measurement,
- edge crack testing,
- position acquisition of components or machine parts.

The measurement system may only be operated within the range of figures specified in the technical data, see Chap. 3.5.

The system should only be used in such a way that in case of malfunction or failure personnel or machinery are not endangered.

With safety-related applications precautions must also be taken for safety and for damage prevention.

1.5 Proper Environment

- Protection class

Laser / receiver:	IP 64 (applies only with connected cable)
Controller:	IP 40
- The level of protection does not apply to the optical paths during operation, because if they become contaminated, the function is impaired or fails completely.
- Operating temperature: 0 - 50 °C (with free air circulation)
- Relative humidity: 5 - 95 % (non-condensing)
- Ambient pressure: Atmospheric pressure
- Vibration: according to IEC 68-2-6 (only for laser / receiver)
- Mechanical shock: according to IEC 68-2-29 (only for laser / receiver)
- Storage temperature: -20 up to +70 °C
- Only use screened leads or the original cable from the range of accessories for connecting a power supply unit and for the outputs.

- **i** The protection class is restricted to water (no drilling emulsions, etc.)!
Use a protective housing if the effects of water are continuous.

2. Laser Class

The light source for the optoCONTROL 2500 consists of a semiconductor laser. The wave length is 670 nm (visible / red) with a maximum optical output power of 0.39 mW. The sensors are classified in Laser Class 1.

The accessible radiation is harmless under predictable conditions.

The following information labels are fitted to the laser housing, see Fig. 1:

The laser warning labels for Germany are already printed on the housing. The warning labels for the EU region and the USA are enclosed and must be fitted by the user for the relevant applicable region before putting the equipment into operation.

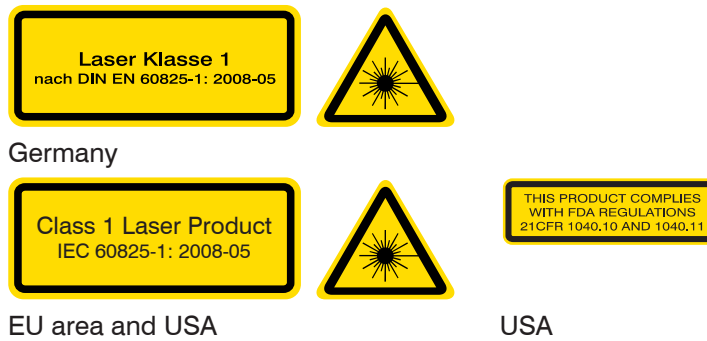

Fig. 1 Warning labels

Impairment of color vision and inconvenience may not be excluded for class 1 laser devices, e. g. through glare.

On the controller („Laser On“) and on the light source, an LED signals through its illumination that laser radiation is being emitted from the optical opening on the light source, see Fig. 2, see Fig. 7.

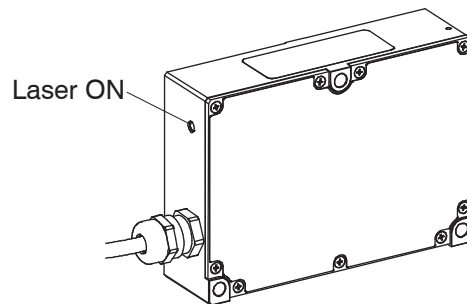

Fig. 2 LED on the light source

Consequently, you can use Class 1 laser equipment without further protective measures. Class 1 lasers are not subject to registration and a laser protection officer is not required.

- ⓘ The housing of the receiver and laser may only be opened by the manufacturer!
- ⓘ For repairs and service the sensor must always be sent to the manufacturer!



Fig. 3 Sensor unit with warning labels

3. Functional Principle, Technical Data

3.1 Measurement Principle

optoCONTROL 2500 is a laser-based measurement system with an integral high resolution line scan camera for the measurement of geometrical quantities. The optoCONTROL 2500 measures the dimension of a target or the position of an edge on a body according to the shadow principle and without making physical contact. A parallel light curtain is produced with the laser light source. The line scan camera in the receiver measures the contour of the target with high accuracy using the shadow created.

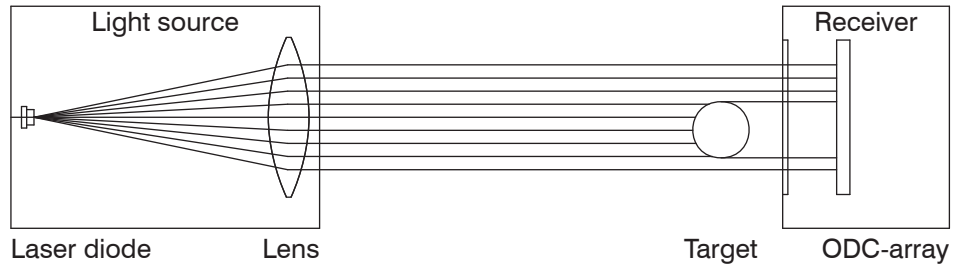

Fig. 4 Measurement principle

3.2 Structure of a Complete Measurement System

optoCONTROL 2500 consists of a sensor unit SU and a controller CU. The sensor unit incorporates a laser light source and a receiver with a line scan camera which are mounted on the mounting rail enclosed with the supplied items. The sensor unit is controlled and evaluated by an intelligent controller with graphical display for operation and measurement indication. The data obtained with the various selectable measurement programs are output via analog and digital interfaces.

i The light source and receiver are assigned to specific separate controller and must not be switched.

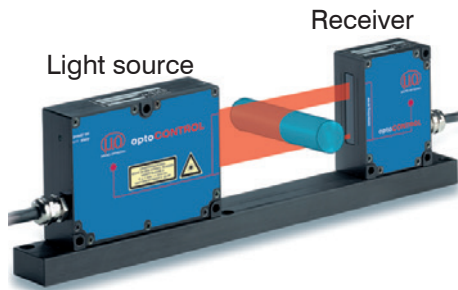

Fig. 5 Sensor unit SU



Fig. 6 Controller CU

- A measurement system consists of:
- laser
 - receiver
 - controller

3.3 Controller

3.3.1 Front View of the Controller

The interactive operation is supported by an LC graphical display with illuminated screen. The controller is operated with the four keys on the front panel, see Fig. 7.

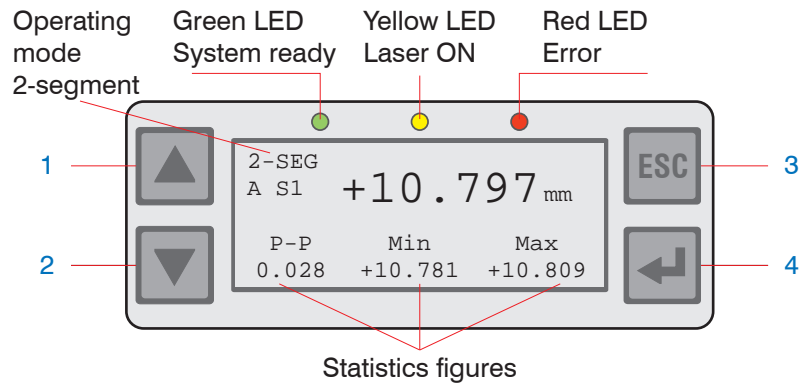

Fig. 7 Keypad and display on the front panel of the controller

The following functions are assigned to the keypad, see Fig. 7:

- (1), (2) Up / down movement in menus,
- value input: (1) greater, (2) smaller
- (3) Quitting a menu point, change to the next higher hierarchical level
- (4) Entry into the selected menu point, confirmation of entry

Below the operating mode (e.g. DIA, EDGE) A for absolute or R for relative measurement is displayed.

In the „2-segment“ operating mode (2-SEG) the code for the selected segment also appears (S1 or S2).

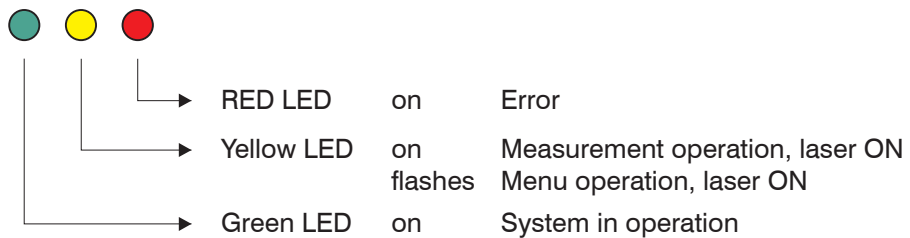

Fig. 8 LEDs on the front panel of the controller

3.3.2 Rear View of the Controller

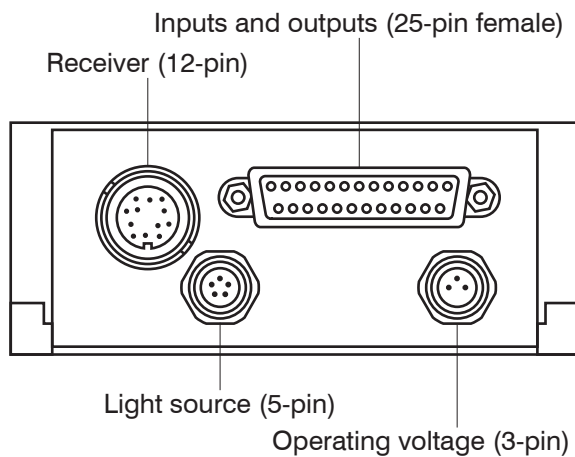
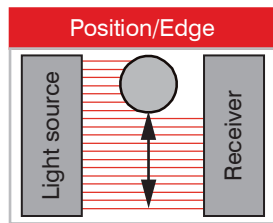

Fig. 9 Connectors at the back of the controller

3.4 Operating Modes

The following operating modes are selectable via a menu-assisted („Select measurement program“, see Chap. 6.3.6) selection:



Position of an edge (dark - bright)

EDGELH			
A	+26.411 mm		
P-P	Min	Max	
+0.812	+25.896	+26.708	

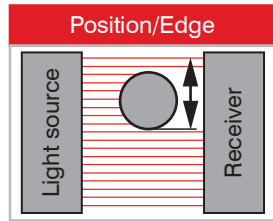

Position of an edge (bright - dark)

EDGEHL			
A	+14.661 mm		
P-P	Min	Max	
+0.972	+14.011	+14.983	

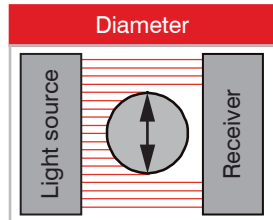

Diameter of a target

DIA			
A	+15.074 mm		
P-P	Min	Max	
+0.005	+15.071	+15.076	

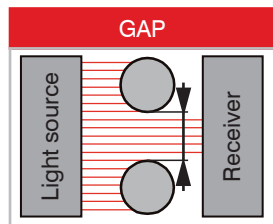

Gap between two targets

GAP			
A	+11.763 mm		
P-P	Min	Max	
+0.487	+11.575	+12.062	

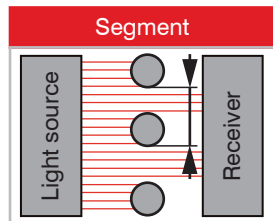

Distance between two selectable edges (segment) (in the example segments 2-4)

SEG_2_4			
A	+17.100 mm		
P-P	Min	Max	
+16.983	+0.466	+17.450	

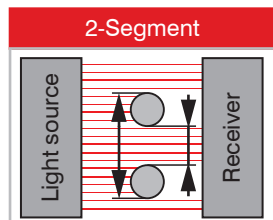

Alternating measurement of two freely selectable segments (in the example segments 1-4 and 2-3)

2-SEG			
A S 1	+14.815 mm		
P-P	Min	Max	
+0.012	+14.810	+14.822	

2-SEG			
A S 2	+11.768 mm		
P-P	Min	Max	
+0.010	+11.761	+11.771	

Fig. 10 Methods of operating

For each measurement program 2 limits and 2 warnings can be programmed.

For the 2-segment program only 2 limits per segment can be programmed.

Application-specific measurement programs can also be generated by menu.

3.5 Technical Data

Measurement range	0.5 mm ... 34 mm	
Measuring rate (sampling rate)	2.3 kHz	
Smallest measurable diameter or gap	0.5 mm	
Minimum distance from diameter step (recess) on target to the measuring point	0.2 mm	
Distance of light source - receiver (free space)	150 ... 700 mm	
Linearity, typical for calibrated distances object - receiver:		
20 ±5 mm ¹	±10 μm	
50 ±5 mm ¹	±15 μm	
100 ±5 mm ²	±18 μm	
150 ±5 mm ²	±20 μm	
Resolution ³	1 μm	
Reproducibility	3 μm	
Light source	Semiconductor laser 670 nm, red Power < 0.39 mW, Laser Class 1	
Analog output voltage	0 to 10 VDC, range ±10 VDC, selectable	
Digital output	RS232: max. 115.2 kBaud or RS422: max. 691.2 kBaud	
Switching output	Error, 2x limit, 2x warning, max. 30 VDC; 100 mA;	
Error output	max. 30 VDC; 100 mA; separate for each channel	
Operating temperature	0 ... 50 °C	
Storage temperature	-20 up to 70 °C	
Cable length	Standard:	2 m
Controller-Laser or Controller - camera	Extension:	3 m or 8 m
Extraneous light	Outside of the receiver range approximately 8.000 Lux (direct radiation 1.000 Lux)	
Operating voltage	+24 VDC ±15 %, < 1 A	
Level of protection	IP 64 (Light source, receiver) IP 40 (controller)	
Measurement programs	<ul style="list-style-type: none"> - Edge bright - dark - Edge dark - bright - Diameter - Gap - Segment - 2-segment - 4 user programs (can be edited) 	
Dimensions	H x W x D	
Light source	110 x 72 x 28 (4.33 x 2.83 x 1.10)	
Receiver	54 x 72 x 28 (2.13 x 2.83 x 1.10)	
Controller (without connector)	191 x 110 x 45 (7.52 x 4.33 x 1.77)	
Mounting rail (for light source and receiver)	15 x 30 x 494 (.59 x 1.18 x 19.4)	
Weight	Controller	1000 g
	Light source	400 g
	Receiver	300 g
	Mounting rail	600 g

Dimensions mm (inches)

Displays	<ul style="list-style-type: none"> - LCD-display (value, maximum, minimum, (peak-to-peak)) - Measurement indication in mm or inch, selectable - Menu language in German or English, selectable - 3x LED (Power on, Laser on, Error)
Vibration ⁴	acc. IEC 60068-2-6 2 g / 20 ... 500 Hz
Shock ⁴	acc. IEC 60068-2-29 15 g / 6 ms
Inputs	<ul style="list-style-type: none"> - Zero point (Zero) - Synchronization - Laser on / off (can be turned off via menu)
Accessories, optional	<ul style="list-style-type: none"> - Cable extensions for light source and receiver (3 m or 8 m) - Power supply cable (3 m or 10 m) - Signal output cable (signal and switching outputs): Analog (3 m) + RS232 (3 m) Analog (3 m) + RS422 (10 m)

The quoted data apply for a constant room temperature of 20 °C, sensor in continuous operation.

- 1) Measured at a distance, light source - receiver 150 mm
- 2) Measured at a distance, light source - receiver 300 mm
- 3) Display resolution
- 4) Data apply to the sensor unit
- 1) +2) Operating Mode: Edge

3.6 Block Diagram

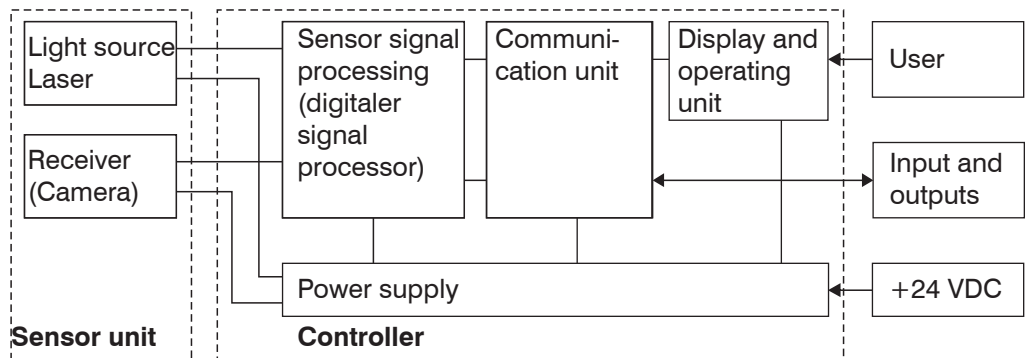

Fig. 11 Block diagram of the ODC2500 measuring system

3.7 Analog Output

Output voltage (without offset):	0 ... 10 VDC
Max. output range (with offset, gain):	-10.0 V ... +10.0 VDC
Output span (= 100 % of measurement range):	U_{OUT} 10.0 VDC
Output voltage (with error indication)	-10.04 V ... +10.04 VDC
Internal resistance:	100 Ohm
Minimum load resistance:	1 kOhm
Recommended load resistance:	1 MOhm
Maximum capacitive load	47 nF

Analog output, see Chap. 6.4.

3.8 Zero-Setting Input

By briefly connecting (0.5 to 3 s) together the inputs „Set zero“ (Signal and GND) during measurement, the measurement is set to the default master value, see Chap. 6.3.7.2 . If a master value has not yet been entered, the measurement is set to 00.000 during zero setting.

- Zero-setting input on the 25-pin connector:
- ! Pin 5: Signal Pin 18: GND

If the zero-setting input is activated for between 3 and 6 s (closed), resetting occurs to the measurement without masters or zeroes.

Pulses which are shorter than 0.5 s or longer than 6 s are not processed.

The zero-setting input is only active in the measurement mode with valid measurements.

In the „2-segment“ operating mode and with erroneous measurements, no zero-setting is possible.

The zero-setting input only affects the display and the analog output. The digital output is not affected.

3.9 Synchronization

If two or more optoCONTROL 2500s are operated on the same target, they can be synchronized to one another, see Chap. 6.5.

As Master, Controller 1 then synchronizes Controller 2.

All synchronization signals are electrically isolated by optocouplers.

3.10 Error Output

If an error is detected by the measurement system (e.g. no target present, too much extraneous light, etc.), then the switching output „Error“ becomes conducting. The error output always refers to the unaveraged measurements (at a rate of 2.3 kHz).

The red light emitting diode (Error LED) also indicates the error.

Output wiring, see Chap. 12.

- The error output is provided on the 25-pin connector.
- ! Pin 1: Error output Pin 2: GND

3.11 Laser Switch-off

In the menu Options you can also activate the switching input for the external laser switch-off. The light source is then active (Laser on) when the input is short-circuited.

As supplied the input is not activated, so that nothing needs to be connected to the 25-pin socket in order to put the system into operation.

4. Delivery

4.1 Supplied Items

- 1 Controller
- 1 Light source
- 1 Receiver
- 1 Mounting rail with mounting screws for light source and receiver
- 1 25-pin Sub-D plug
- 1 3-pin circular plug
- 1 Operating manual

➤ Carefully remove the components of the measuring system from the packaging and ensure furthermore that the goods are forwarded in such a way that no damage will occur.

ⓘ Do not touch the optical windows. Dirt on the optical window will eventually affect the functionality.

➤ Check the measuring system for completeness and transport damage immediately after unpacking.

➤ Immediately contact your supplier in the case of damage or incompleteness.

4.2 Storage

Storage temperature -20 up to +70 °C

Relative humidity up to 95 % RH, non-condensing

5. Installation and Mounting

5.1 Precautions

No sharp-edged or heavy object should be allowed to affect the cable. The connecting cables from the light source and receiver are compatible with use as trailing cables. Kinks in the cables must always be avoided.

ⓘ Do not touch the optical windows. Dirt on the optical window will eventually affect the functionality.

5.2 Mounting the Sensor Unit

The sensor unit, consisting of the light source, receiver and mounting rail, see Fig. 12, is pre-assembled. The light source can be fitted to the mounting rail at two different distances (150 or 300 mm) to the receiver.

ⓘ Sensor unit and controller form a unit. Do not change with components of different serial numbers.

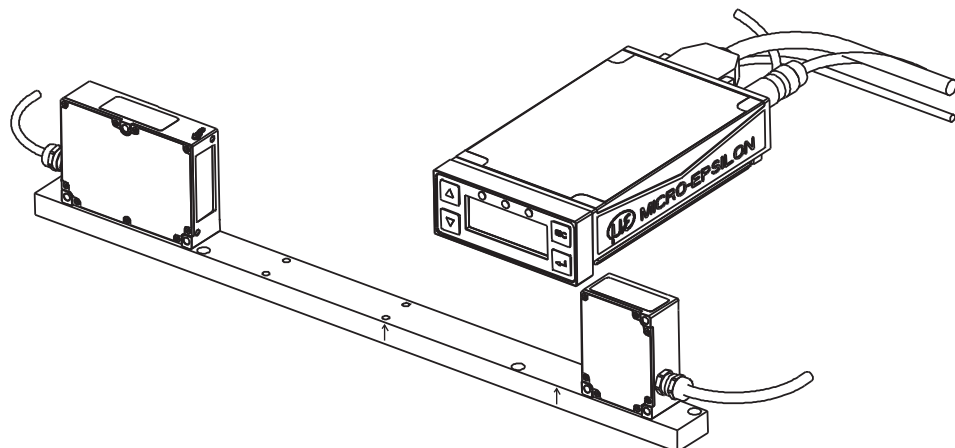

Fig. 12 Mounted sensor unit with controller

The mounting rail must be fixed so that it is not bended respectively twisted.

The sensor unit is calibrated in the controller to four different measurement distances:

- Receiver - target: 20 mm and 50 mm, distance between light source and receiver 150 mm

and

- Receiver - target: 100 mm and 150 mm, distance between light source and receiver 300 mm.

Other distances of the light source to the receiver are possible, but may slightly affect the linearity of the measurement. The maximum distance (free space) between the light source and receiver is 700 mm.

- Standard setting receiver - target: 20 mm and 50 mm, distance between light source and receiver: 150 mm

A dimensioned drawing of the sensor unit, see Fig. 13.

With the free mounting of the light source and receiver sensor components, attention must be given to the precise alignment of the housing edges. The housing edges must lie in one plane. The maximum angular deviation is 1°. A try square or rail are suitable aids for alignment.

The supplied mounting screws or other suitable M4 screws should be used for fixing. Please note the threaded depth of 5 mm in both components.

For bolting on, the three 4.5 mm through holes in each component can be also used. A horizontal measurement arrangement reduces contamination on the optical system and should therefore be preferred.

NOTICE

Mount the sensor only to the existing holes on a flat surface. Clamps of any kind are not permitted.

> Inaccurate, erroneous measuring values

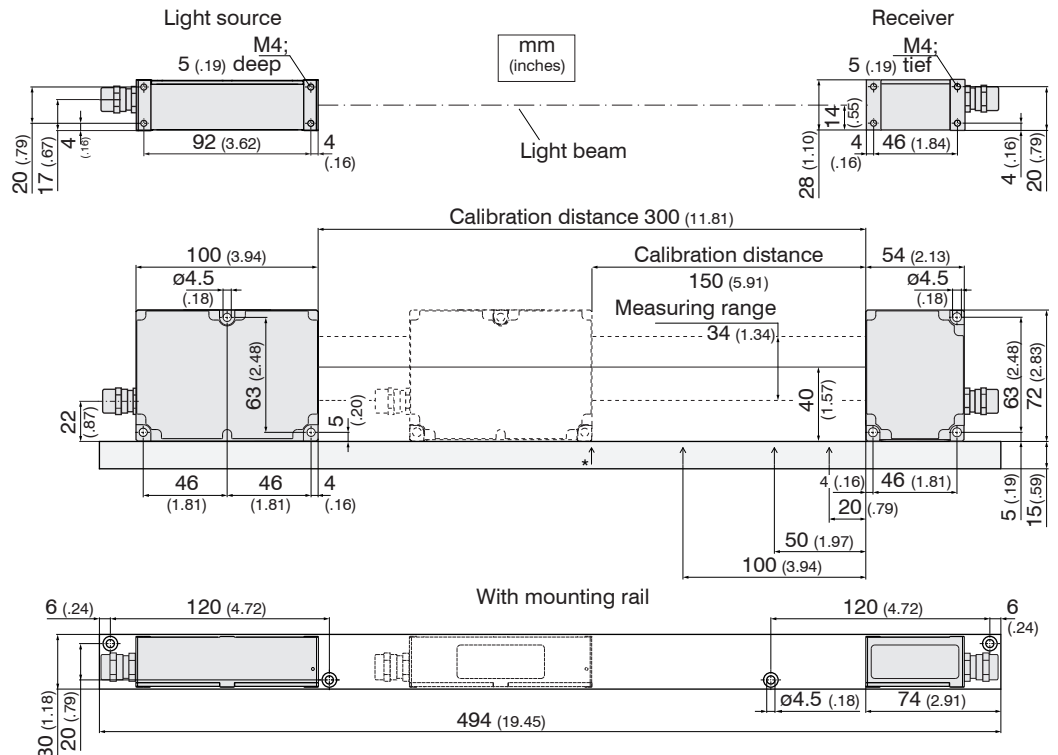

Fig. 13 Dimensional drawing sensor unit, dimensions in mm (inches), not to scale

Arrows on the mounting rail show you the calibrated target positions

Minimum cable bending radius

Light source (5-pin)	flexible: 35 (1.38)	fixed: 23 (.91)
Light source extension cable CE2500-x	flexible: 35 (1.38)	fixed: 23 (.91)
Receiver (12-pin)	flexible: 49 (1.93)	fixed: 33 (1.39)
Receiver extension cable CE1800-x	flexible: 49 (1.93)	fixed: 33 (1.39)

➡ Connect the light source (5-pin) and the receiver (12-pin) with the controller.

The max. distance between light source and receiver is 700 mm.

ⓘ The light source and receiver must lie in one plane and must not be tilted with respect to another.

Control the centred alignment of the light beam at the receiver after installation of the light source and of the receiver in the correct displacement. You may control the concentric orientation of the light beam both in the horizontal and the vertical orientation.

For this purpose it is recommended, to keep a white paper as a projection plane ahead of the receiver and to cover the window halfway through, see Fig. 14, see Fig. 15. For the vertical orientation also the color filter on the sensors surface can be used. The light beam should illuminate this up to the edge (± 0.5 mm) symmetrically. For the horizontal alignment use the engraved lines on the sensors surface, which have to be illuminated also.

You may loosen the light source for an accurate positioning if required.

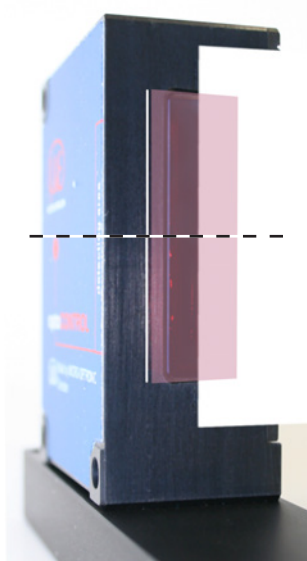

Fig. 14 Vertical adjustment controlling with white paper

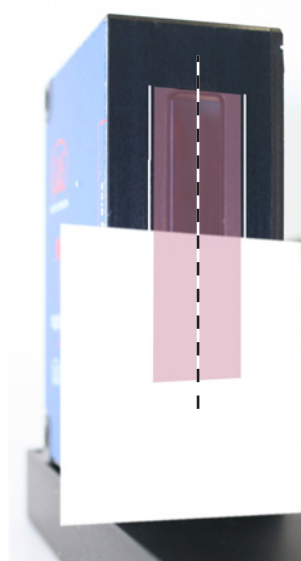

Fig. 15 Horizontal adjustment controlling with white paper

5.3 Mounting the Controller

The controller can be mounted in any orientation.

- ➔ The controller should be mounted with four M4 screws (not included in the supplied items) on a flat mounting plate.
- ➔ Make sure there is sufficient space for the connector and cable.

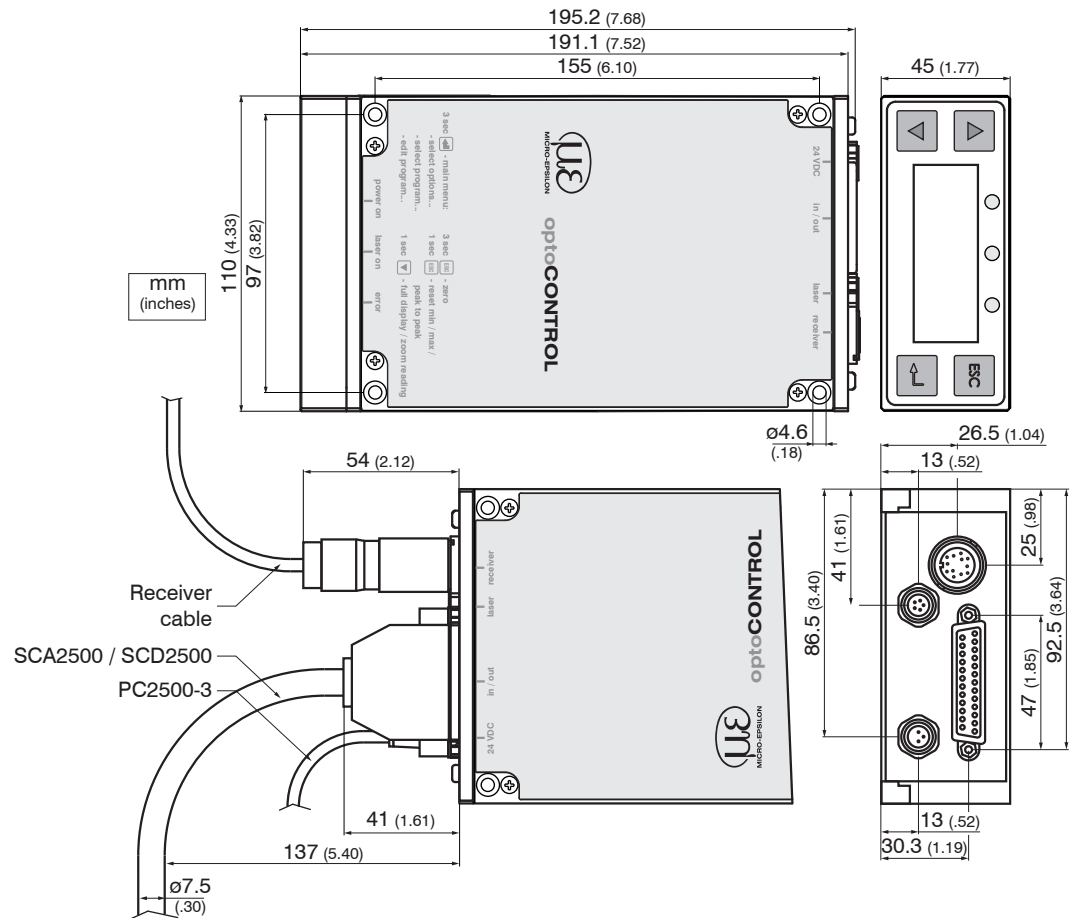

Fig. 16 Dimensional drawing controller, dimensions in mm (inches), not to scale

Minimum cable bending radius

Signal output cable	flexible: 96 mm (3.78 inches)	fixed: 40 mm (1.57 inches)
SCA2500 / SCD2500		
Supply cable PC2500-3	flexible: 70 mm (2.75 inches)	fixed: 50 mm (1.97 inches)

5.4 Supply Voltage

- ➔ Connect the 24 VDC female connector with a 24 V power supply.

The operating voltage is preferably connected via a screened two-core cable, e.g. via the supply cable PC2500-3. Route the cable screen to a potential equalization terminal in the vicinity of the power supply unit. The controller contains a inverse-polarity protection.

Pin-no.	Signal	Conductor coloring PC2500, (old version)	
1	GND of operating voltage	black	(brown or blue)
2	N.C.	---	
3	+24 VDC ($\pm 15\%$), < 1 A	red	(white)
Housing	Cable screen	tin-plated	

Fig. 17 3-pin male cable connector (type Binder), view on solder pin side

- The operating voltage is protected against reverse connection.
- The sensor should be furnished with the expected noise on the supply voltage caused by inductive loads (eg motors, contactors, solenoid valves, etc.) from a small separate power supply for measuring equipment.

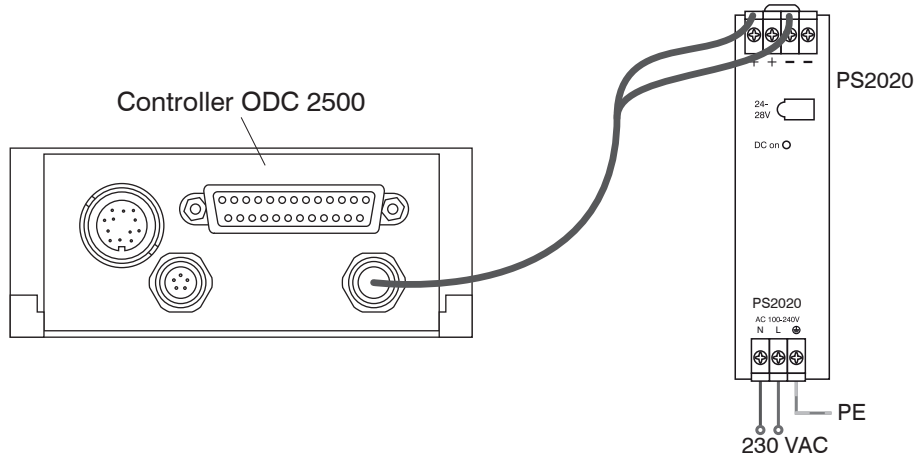

Fig. 18 Power supply of the ODC2500 with a PS2020

5.5 Connecting of Terminal Equipment

5.5.1 Connectivity Overview

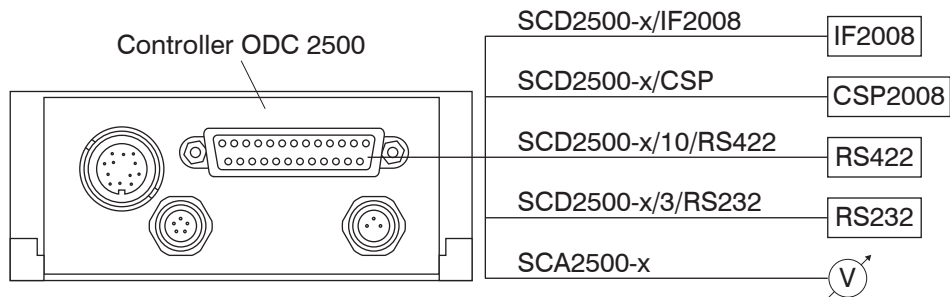

Fig. 19 Connectivity ODC2500

Pin-No.	Signal	Signal type / connector type
1	Error output (Signal)	Switching output
14	Error output (GND)	Switching output
2	High limit (Signal)	Switching output
15	High/low limit (GND)	Switching output (common connection)
3	Low limit (Signal)	Switching output
16	High warning (Signal)	Switching output
4	High/low warning (GND)	Switching output (common connection)
17	Low warning (Signal)	Switching output
5	Zero point (Signal)	Switching input (Zero)
18	Zero point (GND)	Reference potential for ZERO
6	Input Laser OFF (Signal)	Switching input
19	Input Laser OFF (GND)	Reference potential for switching input
20	RS422 Receive (inverted)	Optocoupler input (positive)
7	RS422 Receive (positive)	Optocoupler input (negative)
8	RS422 Send (positive)	Serial output (negative impedance)
21	RS422 Send (inverted)	Serial output (positive impedance)
9	RS232 Receive (RxD)	Serial input (RS232)
22	RS232 DGND	Reference potential for RS232
10	RS232 Send (TxD)	Serial Output (RS232)
23	Synchronization output (+)	Digital output (SYNC)
11	Synchronization output (-)	Reference potential (DGND)
24	Synchronization input (+)	Optocoupler - Input (positive)
12	Synchronization input (-)	Optocoupler - Input (negative)
25	Analog output (AGND)	Reference potential for analog signal
13	Analog output (Signal)	Analog signal (voltage)

Fig. 20 Sub-D connector, 25-pin

Comment:

- All GDN signals are connected internally with one another and with the minus pole (GND) of the 24 V operating voltage.
- DGND and AGND are internally electrically connected, but isolated from the minus pole (GND) of the 24 V operating voltage.

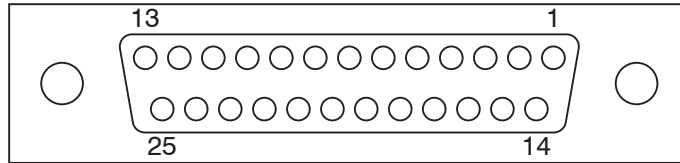

Fig. 21 25-pin Sub-D male connector, solder pin side

5.5.2 PCI-Interface Card IF2008

The IF2008 enables the synchronous capture of up to 4 digital sensor signals and 2 encoders.

An ODC 2500 Controller is connected to the IF2008 Interface card from MICRO-EPSILON Eltrotec GmbH via the SCD2500-x/IF2008 signal output cable on the socket X1 (Sensor 1).

A second ODC 2500 can be plugged onto the X2 socket (Sensor 3).

For the connection of more than two ODC 2500 sensors to one IF2008 you require an IF2008-Y adapter cable from MICRO-EPSILON Eltrotec GmbH.

The interface parameters on the ODC 2500 must be set to the active RS422 interface and the following standard settings made:

Baud rate: 691200 Baud

Data format: 8 data bits, no parity, 1 stop bit (8, N, 1)

➡ First switch on downstream computers and after that the controller.

All inputs are electrically isolated by optocouplers both on the ODC 2500 controller and on the IF2008 Interface Card.

Further information can be found in the documentation for the IF2008, ICONNECT and LibOPTO from MICRO-EPSILON Eltrotec GmbH.

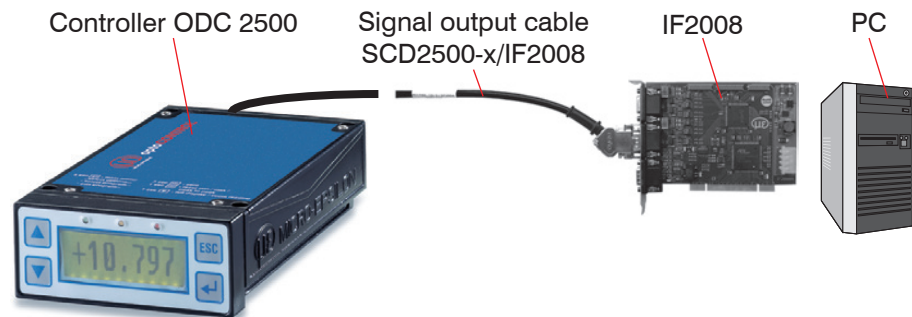

Fig. 22 System setup for the operation of Interface card IF2008

	Pin on Controller (HD-Sub 25)	Interface card IF2008 Bush X1 (oder X2)	15-pin Sub-D, IF2008	
Controller ODC 1	7	Sensor 1 (3) TxD+	2	IF2008, X1 und X2, 15-pin Sub-D
	20	Sensor 1 (3) TxD-	1	
	8	Sensor 1 (3) RxD+	4	
	21	Sensor 1 (3) RxD-	3	
	24	Sync In+	6	
	12	GND	15	
		NC	7	
		NC	8	
		NC	9	
		NC	10	
Controller ODC 2	7	Sensor 2 (4) TxD+	2	
	20	Sensor 2 (4) TxD-	1	
	8	Sensor 2 (4) RxD+	4	
	21	Sensor 2 (4) RxD-	3	
	24	Sync In+	6	
	12	GND	15	

Fig. 23 Pin assignment on the RS422 between IF2008 and ODC2500

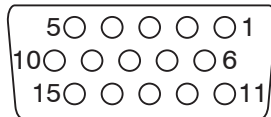

Fig. 24 15-pin HD sub-miniature connector, viewed on solder side.

25-pin Sub-D	Signal	15-pin Sub-D	Core colors
1	Error output (Signal)		red
14	Error output (GND)		blue
2	High limit (Signal)		violet
15	High/low limit (GND)		black and brown
3	Low limit (Signal)		white
16	High warning (Signal)		pink
4	High/low warning		gray and gray / pink
17	Low warning (Signal)		red / blue
20	RS422 Receive (inverted)	1	
7	RS422 Receive (positive)	2	
8	RS422 Send (positive)	4	
21	RS422 Send (inverted)	3	
24	Synchronization input (+)	6	
12	Synchronization input (-)	15	
25	Analog output (AGND)		black (inside conductor)
13	Analog output (Signal)		green
			black (outer shield to connector housing 25-pin.)

Fig. 25 Pin assignment for SCD2500-x/IF2008 (15-pin)

5.5.3 Universal Controller CSP2008

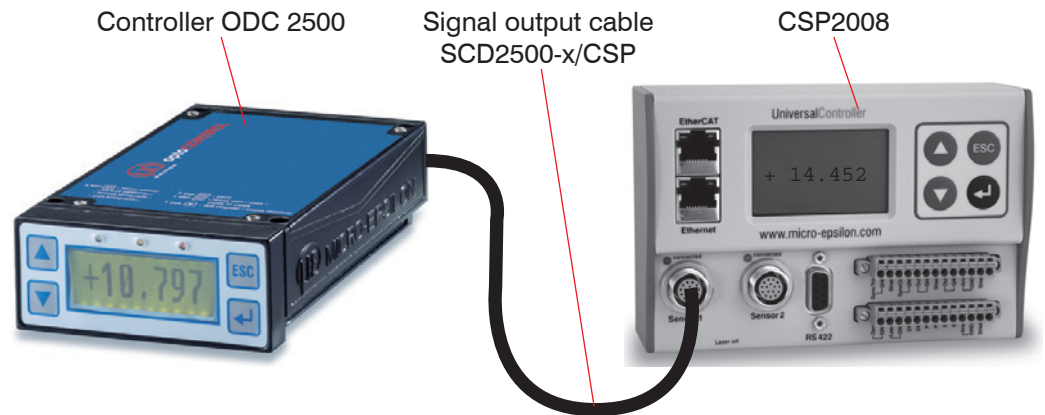

Fig. 26 System setup for the operation of CSP2008

The universal controller CSP2008 is used for processing at least two digital input signals.

- Programmable via buttons or Ethernet (websites)
- Semi-automatic sensor recognition for sensors from Micro-Epsilon Eltrotec GmbH with digital output
- Rail mounting (TS35)
- Triggering, synchronization and other functions
- Ethernet interface with TCP and UDP protocol

5.5.4 Connecting an Analog Terminal Device

For connecting an analog terminal device use either the analog connecting cable from the accessories or your own screened cable.

When using the connecting cable SCA2500 (see Accessories), the outer screen must be connected to the receiver screen (e.g. plug housing).

The inner screen acts as the signal return conductor (analog ground AGND) and must be connected to the receiver ground. This screen should not have any connection to the housing screen (plug housing).

When using your own cable, a single-core screened cable is recommended, the screen of which is used as the signal return conductor (analog ground AGND). This screen must not have any connection to the housing screen (plug housing) and the receiver screen.

In the case of interference try connecting the outer screen to the receiver screen with a ceramic capacitor of 10 to 100 nF or not connecting it at all.

A capacitor of up to 47 nF can be wired in parallel to the input of the evaluation device to counter any high frequencies and pulse-shaped parasitic interference on the analog signal.

Route the analog connecting cable according to the general applicable rules in measurement engineering, i.e. for example, not directly next to pulse-loaded lines (separate cable duct).

i The interface cables SCD250-x/x/RSxxx also have an analog output and can thus be used for connection of an analog equipment.

Pin-No.	Signal	Signal type / connector type	Core colors in the SCA2500-x Signal and Output Cable
1	Error output (Signal)	Switching output (Open collector)	red
14	Error output (GND)	Switching output	blue
2	High limit (Signal)	Switching output (Open collector)	violet
15	High / low limit (GND)	Switching output (Common connection)	black and brown
3	Low limit (Signal)	Switching output (Open collector)	white
16	High warning (Signal)	Switching output (Open collector)	pink
4	High / low warning	Switching output (Common connection)	grey and grey / pink
17	Low warning (Signal)	Switching output (Open collector)S	red / blue
25	Analog output (AGND)	Reference potential for analog signal	Inner screen (thin cable)
13	Analog output (Signal)	Analog signal (voltage)	green

Fig. 27 Pin assignment, standard analog output cable

Pin-No.	Signal	Signal type / connector type	Core colors in the SCA2500-x(01) Signal and Output Cable
1	Error output (Signal)	Switching output	red
14	Error output (GND)	Switching output	blue
5	Zero point (Signal)	Switching input	white
18	Zero point (GND)	Switching input	grey/pink
6	Input Laser OFF (Signal)	Switching input	pink
19	Input Laser OFF (GND)	Switching input	black
11	Synchronization output (-)	Potential (DGND)	grey
23	Synchronization output (+)	Digital output (SYNC)	violet
12	Synchronization input (-)	Optocoupler input (-)	brown
24	Synchronization input (+)	Optocoupler input (+)	red/blue
13	Analog output (Signal)	Signal (voltage)	green (internal)
25	Analog output (AGND)	Potential (AGND)	Inner screen

Fig. 28 Pin assignment, optional signal and output cable SCA2500-x(01)

5.5.5 RS232 and RS422

The RS232 serial interface allows the serial connection between a data terminal equipment (DTE) and a data transmission device (DCE).

The achievable distance between two RS232 devices depends, as with all serial transmission methods of cable used and the baud rate. As a normative standard should at a transmission rate of 9600 baud a distance 15 to 30 meters not be exceeded.

The RS422 interface is suitable for high-speed serial data transmission over long distances. The use of unshielded twisted pair level-5 cable can realize data transmission over distances of up to 1200 meters at a speed of up to 100,000 baud.

With both interfaces the RSxxx / USB converters are used for connecting to a PC.

25-pin	Signal	9-pin	Core colors
1	Error output (Signal)		red
14	Error output (GND)		blue
2	High limit (Signal)		violet
15	High/low limit (GND)		black and brown
3	Low limit (Signal)		white
16	High warning (Signal)		pink
4	High/low warning (GND)		gray and gray / pink
17	Low warning (Signal)		red / blue
9	RS232 Receive (RxD)	3	
22	RS232 DGND	5	
10	RS232 Send (TxD)	2	
25	Analog output (AGND)		black (inner conductor)
13	Analog output (Signal)		green
			black (outer screen to connector housing 25-pin)

Fig. 29 Pin assignment SCD2500-x/3/RS232

25-pin	Signal	9-pin	Core colors
1	Error output (Signal)		red
14	Error output (GND)		blue
2	High limit (Signal)		violet
15	High/low limit (GND)		black and brown
3	Low limit (Signal)		white
16	High warning (Signal)		pink
4	High/low warning		gray and gray / pink
17	Low warning (Signal)		red / blue
20	RS422 Receive (inverted)	1	
7	RS422 Receive (positive)	2	
8	RS422 Send (positive)	4	
21	RS422 Send (inverted)	3	
25	Analog output (AGND)		black (inner conductor)
13	Analog output (Signal)		green
			black (outer screen on connector housing 25-pin)

Fig. 30 Pin assignment SCD2500-x/3/RS422

5.6 Switching Outputs

All switching outputs, see Fig. 20, have the same internal circuit (open collector). In the active state the associated output transistor conducts to GND.

For obtaining logical signal levels, external pull-up resistors to the 24 VDC operating voltage or another external auxiliary voltage are provided, see Fig. 31.

The switching outputs are protected against overload and reverse connection. When connecting inductive loads (e.g. relays), always fit protective diodes across the load! All GND signals are connected together internally and to the minus pole (GND) of the 24 V operating voltage.

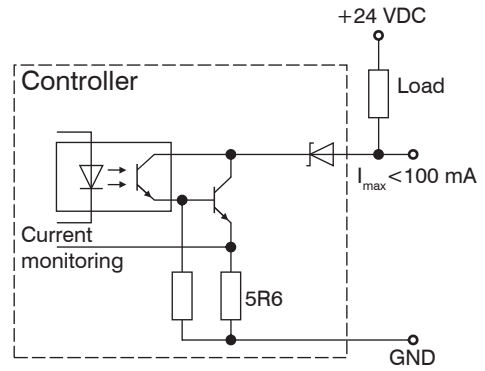

Fig. 31 Circuit diagram for switching output, with external load (e.g. pull-up resistor), see Fig. 20, for pin assignment.

5.7 Switching Inputs

Application: Laser off, Zero-point

Inputs are, for example, connected through relay contacts or transistors (optocouplers). Activate the laser switch-off in the relevant menu, see Chap. 12.1.3. All GND signals are connected together internally and with the minus pole (GND) of the 24 V operating voltage.

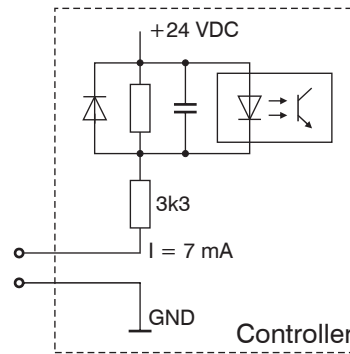

Fig. 32 Basic circuit diagram for switching inputs

5.8 Synchronization Input

The input is triggered by a further controller or another device.

$$R_{\text{ext}} = (U_{\text{HIGH}} - U_{\text{F}} - (I_{\text{LED}} * 100 \text{ Ohm})) / I_{\text{LED}}$$

Example: $U_{\text{HIGH}} = 3.3 \text{ V}$
 $I_{\text{LED}} = 15 \text{ mA}$
 $U_{\text{F}} = 1 \text{ V}$
 $R_{\text{ext}} = 53.3 \text{ Ohm, also } 56 \text{ Ohm}$

All GND signals are connected together internally and with the minus pole (GND) of the 24 V operating voltage.

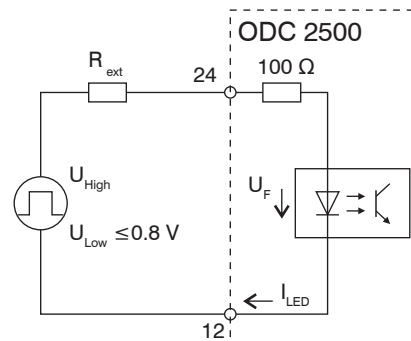

Fig. 33 Circuit synchronization input, 25-pin Sub-D

6. Operation

6.1 Putting into Operation

- Connect the light source and receiver to the controller before the system is put into operation and all connectors secured with the screw connections, see Chap. 5.2.
- Switch on downstream computers.
- Switch on the 24 VDC operating voltage at the controller.
- Check, where necessary under darkened ambient light, whether the light beam impinges centrally on the receiver.

NOTICE

During the operation, i.e. with the operating voltage switched on, the light source and receiver must not be unplugged.

Risk of damage to light source / receiver or the controller.

The engraved marks on the receiver provide orientation.

As delivered, the measurement system is programmed to the standard setting of „Edge bright - dark“. The distance from the target to the receiver is set to 20 mm.

- With other distances select the nearest distance via the menu, see Chap. 5.2, see Chap. 12.1.5.

If there is no target in the beam path, then the red LED (Error) lights.

6.2 Menu Structure

A detailed representation of the operating concept can be found in the annex.

Select options:

- Contrast
- Language
- Measurement unit (mm or inch)
- Error handling (analog output)
- Interface parameters (active interface, RS232 or RS422)
- External laser control (Laser On / Off)
- Clear user data
- Video signal
- Service menu (password protection, only for manufacturer)

Select measurement program:

- Edge bright - dark
- Edge dark - bright
- Diameter / width
- Gap
- Segment and 2-segment
- User-defined programs (four max.)

Edit measurement:

- Select segments (only for segment and 2-segment program measurement programs)
- Offset / gain, separately for display and analog output
- High limit / low limit
- High warning / low warning
- Distance to target
- Quantity for average
- Master value (not with 2-segment)

i Standard setting in controller:
l Distance between target and receiver is 20 mm.

6.3 Operating the System

6.3.1 Key Functions

The following functions are assigned to the keypad, see Fig. 7.

- ▲ ▼ Up/down movement in the menus, display selection
Value input: ▲ higher, ▼ lower
- ESC Quits a menu point, changes to the next higher hierarchical level, display reset, zero setting, masters
- ↵ Enters the selected menu point, confirmation of entry

6.3.2 Display

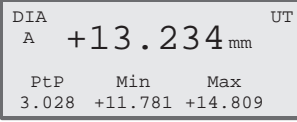
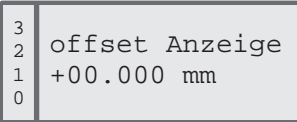
<p>Measurement mode: Yellow light emitting diode is continuously on. The keys ▲ and ▼ toggle in the measurement mode between the two types of display and in the 2-segment program between the measurements for the 1st and 2nd segment. Below the operating mode (e.g. DIA) A for absolute or R for relative measurement is displayed.</p>	<p>Zoom Reading: Large indication of the momentary value</p>	
<p>Menu mode: Yellow light emitting diode flashes.</p>	<p>Full Display: Indication of the momentary value, peak-peak value (P-P), minimum and maximum, measurement programs, limits</p>	
<p>Menu mode: Yellow light emitting diode flashes.</p>	<p>Menu Display: Display of the menu number (left), menu name and any setting parameters.</p>	

The display does not show the measurement at the full measuring frequency, but averaged over 766 measurements (display frequency about 3 Hz) unless the number of averages is set higher than 766.

To monitor all measurements, the display can be selected to „small“ with the key ▲ or ▼ (Full Display). Then MIN, MAX and Peak to Peak (P-P) can be observed at the full measuring frequency. If the formation of the average was activated with > 1, the display refers to the averaged values.

The display can be reset by pressing briefly on the ESC key. There is no automatic reset after a certain time.

6.3.3 Main Menu

By pressing the ↵ key for 3 s you quit the measurement mode and access the main menu. The yellow light emitting diode flashes while you are in the setup menu.

By pressing the ↵ key again you access in turn the submenus. In the left part of the display field the associated menu number appears. The main menu has the number 0000.

The ↵ key takes you progressively deeper into the menu and the ESC key brings you back up the menu hierarchy.

The parameters selectable in the options are read out of the option data of the main memory and written to it again. The operator can decide only on leaving the main menu whether the parameters are to be stored or not. Then the data are retained even after the operating voltage is switched on again.

6.3.4 Options

The set parameters apply independently of the selected measurement program. The standard options can be found in the annex, see Chap. 12.1.3 et seq.. The option data in the main memory is used for the measurement mode. This means that even after quitting the main menu and responding negative to saving the data, the newly selected option data is valid until the measurement system is switched off. If no changes are made at all, then no query for saving is presented on quitting the main menu.

The currently set parameters appear first during selection in the individual menus.

6.3.5 Video Signal

The menu „Options“, see Chap. 12.1.3, contains the spot „video signal“.

The display can show the current video signal of receiver for controlling (not during the measurement). This reflects the intensity in the receiver element.

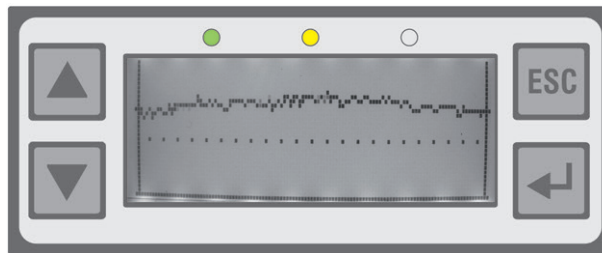

Fig. 34 Typical video signal without target in beam path

Without target the video signal lies clearly above the dotted line throughout, see Fig. 34.

If the video signal presents stronger interferences or breakdowns, that can be down to a contamination of the windows. For careful and residue-free cleaning use a lint-free cleaning rag and some alcohol (isopropanol).

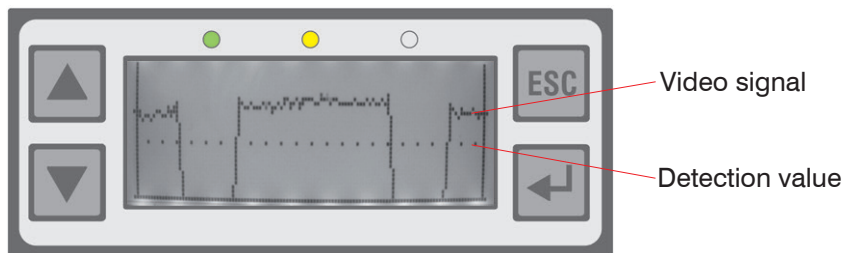

Fig. 35 Video signal with 2 targets (four edges)

The video signal with target has to fall below the detection value for detecting an edge, see Fig. 35.

6.3.6 Select Measurement Program

The six standard measurement programs cannot be modified. They can be used though as templates for your own user-defined measurement programs. First, select a suitable standard program, see Fig. 38.

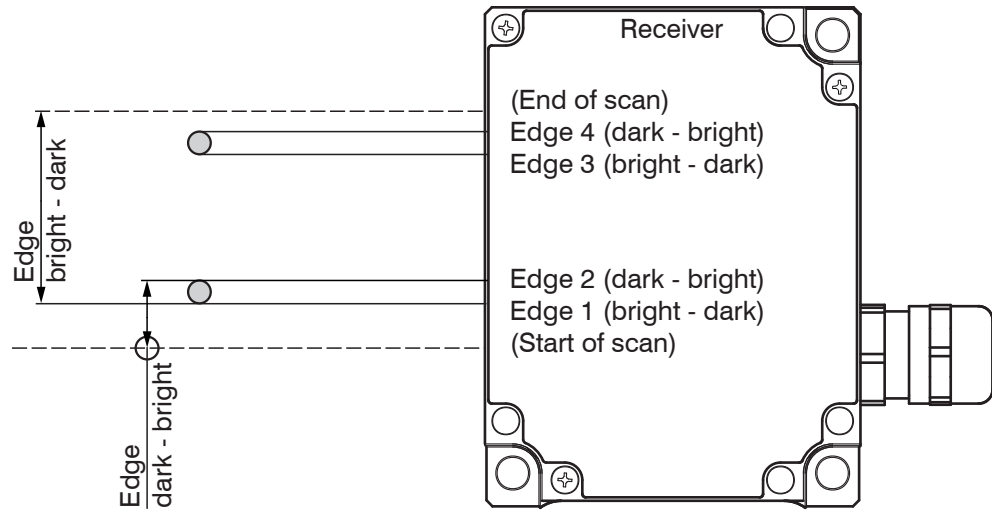

Fig. 36 Definition of terms for measurement programs edge bright - dark and dark - bright

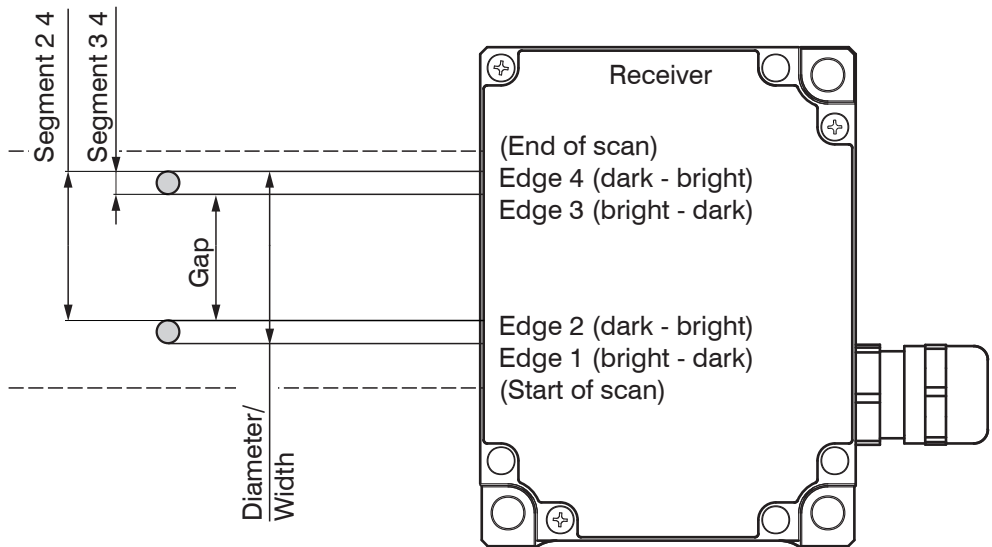

Fig. 37 Definition of terms for measurement programs segment - gap - diameter/width

<p>Edge bright - dark: (EDGEHL) Measurement between first bright-dark edge and end of scan.</p>	
<p>Edge dark-bright: (EDGE LH) Measurement between start of scan and first dark-bright edge.</p>	
<p>Diameter/width: (DIA) Measurement between first bright-dark edge and last dark-bright edge.</p>	
<p>Gap: (GAP) Measurement between first dark-bright edge and the following edge.</p>	
<p>Segment: (SEG_2_4) Measurement between any 2 (from a max. of 32) selectable edges, also possible from zero. Figures show the numbering of the edges in the controller.</p>	
<p>2-Segment: (2-SEG) Alternating measurement of any 2 selectable segments. Display shows with ▲ / ▼ alternating both values. The program 2-segment supports no analog signal. Only high and low limit per segment, see Chap. 12.1.5! Figures show the numbering of the edges in the controller.</p>	<p>1st Segment</p> <p>2nd Segment</p>

Fig. 38 Measurement programs (standard programs)

Further details can be found in the annex under „Operating menu“, see Chap. 12.1.

6.3.7 Edit Measurement Program (User-Specific Programs)

Here, you can carry out user-specific adjustments to the previously selected measurement program.

During selection, the measurement program which is entered in the option data in the main memory is always first displayed.

If parameters have been changed, then you can decide whether these settings are to be retained also after switch-off. Then you must save a user-specific program under a new, freely selected name. This is then automatically activated during switch-on.

„USER1“ or the last user-specified name used appears as a suggestion. These can be overwritten so that the user-specific program can be edited and saved again and again.

If you respond negatively with ESC to the query „Measurement task store?“, the changes made only remain active until the device is switched off.

Up to four user-specific programs are possible. User-specific programs already saved can be called up and activated under „Select program“.

After saving (or responding negatively with ESC), you are again returned to the measurement mode. The measurement program name appears in the measurement display mode „Full Display“ for checking in the display.

- In the measurement program the distance to the target from the receiver must be stated.
- In the operating menu „Options“ you will find in Menu 1900 „Clear user data options + program“ which, after a confirmation query (1910) clears all user-specific programs in the block.

The six standard programs cannot be modified.

6.3.7.1 Zero-Setting Function

By pressing the key ESC for 3 s or during the measurement, the measurement is set to 0.000 if no master value has been saved in the measurement program (e.g. in the factory setting).

- For zero-setting after concluding mastering, the master value must be set again to 00.000.
- Zero-setting is not available in the „2-segement“ measurement program.
- Zero-setting is restricted to the display and the analog output.
- The digital value is not affected.

After zero-setting an R for relative measurement is displayed in the “Full Display” below the operating mode (e.g. DIA).

Zero setting leads to temporary offset values for the display and the analog output. Pressing the ESC key again for 3 s clears the temporary offset values for the display and the analog output. For this however, a valid measurement must be located in the display (not ---). At this point the ESC key, on being pressed for 3 s, takes on as an exception a toggling function between “normal” (absolute) and “zeroed” (relative) measurements.

If the temporary offset values are needed after switch-off, you must move to the main menu (3 s ↵) and leave it again straight away (with ESC). You are then asked whether you would like to save (all changes) and must now save a user-specific program with name.

Different offset values for the display and the analog output can be entered via the menu function.

6.3.7.2 Mastering

Mastering enables balancing the display and analog values to a reference part (master) as single-point calibration. This can for example be practicable if the distance of the target to the receiver does not correspond to any of the four prescribed values (20/50/100/150 mm).

- The master function is limited to the display and the analog output, the digital value is not affected.
- The Mastering is in the measurement program „2-segment“ unavailable.

The known value of the master (reference value) is entered via the menu points “Edit program > Enter value for master” and saved under one of the new user-specific names. Each measurement program can save its own master value.

In the measurement mode the master is placed in the beam at the selected measurement distance and the key “ESC” is pressed for three seconds. The display shows the value of the master. For resetting the “ESC” key is again pressed during the measurement for three seconds. For this however a valid measurement must be located in the display (not —,—).

After mastering an “R” for relative measurement is displayed in the “Full Display” below the operating mode (e.g. DIA).

For the long-term saving of the single-point calibration, also after the operating voltage is switched off, enter briefly into the menu “Main menu” and quit it again with “ESC”. You are then requested to save. You can use the same user-specific name as used for entering the master value. For zero-setting after conclusion of mastering, the master value must be set again to 00.000.

With zero-setting or mastering via the external input by joining the connections Signal (5) and GND (18) together there are two possibilities:

- short pulse from 0.5 to 3 s duration: Zero-setting (or mastering) when a valid measurement is present and no master value is saved in the measurement program.
- long pulse from 3.0 to 6 s duration: Resetting of the master or zero-setting process.

Pulses which are shorter than 0.5 s or longer than 6 s are not processed. The duration of the zero-setting (mastering) depends on the selected average. With averaging over 128 values the process takes about 1 to 2 s and over 4096 values it can take up to 1 minute. Settling to the final value can be observed on the analog output and on the display.

6.3.7.3 Measurement Programs Segment and 2-Segment

If the measurement program „Segment“ (and „2-segment“) is selected, then you can choose the edges between which the distance is to be measured.

Whereas with the normal segment measurement program the distance of any two selectable edges is found and output, with the „2-segment“ measurement program the measurements of two different segments are output consecutively and alternately.

Here, the measurement output is only possible via a digital interface.

The analog output remains switched off at 0 V.

The measurement of the segments occurs simultaneously, but the output serially via the digital interface.

i In the „2-segment“ measurement program the analog output remains switched off at 0 V.

6.3.7.4 Display Scaling

The display values can be changed by the parameters Gain and Offset.

i The function “Display scaling” is not available in the “2-segment” measurement program.

$$\text{Corrected value} = \text{Display value} * \text{Display gain} - \text{Display offset}$$

You can, for example, add a constant value (offset = displacement) or influence the slope of a characteristic by a gain. Entry occurs via „Main menu > Edit program > Enter offset for display“ or „Enter gain for display“.

Entry of a gain should occur before any mastering or zero-setting, where as the offset can be modified after mastering or zero-setting.

To displace the display value add the desired displacement to the displayed displacement and enter the new value at “Display offset”.

In addition a two-point calibration can be carried out. For the two-point calibration it is best to use two reference pieces which correspond to the smallest and largest expected measurements.

- t_l = true measurement (set value), largest dimension
- t_s = true measurement (set value), smallest dimension
- d_l = display value (actual value), largest dimension
- d_s = display value (actual value), smallest dimension

$$\text{Display gain} = \frac{t_l - t_s}{d_l - d_s}$$

$$\text{Display offset} = t_l - \text{Display gain} * d_l$$

Value range display gain: +2 ... +2

Display offset: -99.999 ... +99.999

Example: $t_1 = 8.000 \text{ mm}$ $t_s = 7.000 \text{ mm}$
 $d_1 = 8.005 \text{ mm}$ $d_s = 7.003 \text{ mm}$
 Display gain = 0.99800 Display offset = +0.011 mm

The menu points “Enter offset” and “Enter gain” are not available in the “2-segment” measurement program.

The settings “Offset” and “Gain” for the display or the analog output have no effect on the digital value.

6.3.7.5 Limit Monitoring

The controller can compare the measurement with four different limits. Therefore, thresholds can be monitored, impermissible tolerances detected and sorting criteria realized.

The reference value is always the averaged measurement.

Exception: If 1 is selected for “No. of readings for forming average”, each measurement is a reference value.

The detected high and low limit violations activate the associated switching output at the full measuring rate of 2.3 kHz. In addition, they are shown in the display (top right-hand corner in the “Full display”).

Abbreviation	Standard	2-segment
HW	High warning	High limit, 1 st segment
HW	Low warning	Low limit, 1 st segment
HL	High limit	High limit, 2 nd segment
LL	Low limit	Low limit, 2 nd segment

Fig. 39 Limit allocation

The set limits always refer to the display value.

Example 1: Program DIA, see Fig. 40 for the limit values

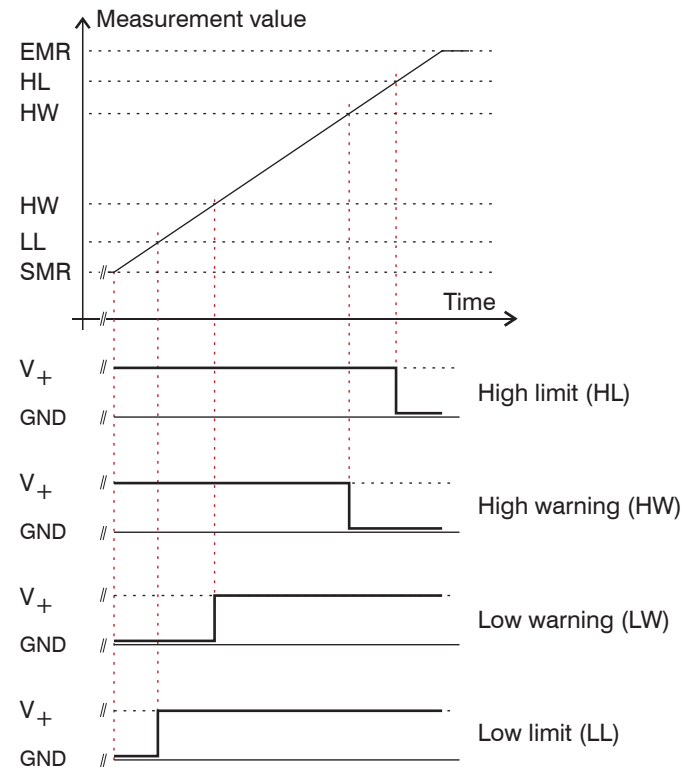

Fig. 40 Limit and error output with different diameters

Example 2: Program DIA, zero setting performed, see Fig. 41, for the limit values.

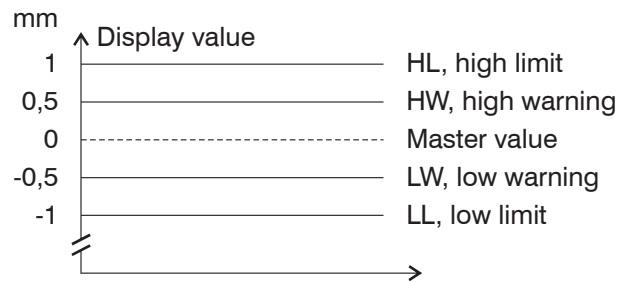

Fig. 41 Limits with zero setting

! The limit output of the „2-segment“ measurement program differs from the other standard programs. For each segment only one high and one low limit can be defined.

6.3.7.6 Averaging

In the measurement system averaging can take place over a selectable number of consecutive measurements. Here, the sliding average is used with a number from 1 to 128 and the recursive average from 129 to 4096. The setting of the averaging number is described in the operating menu in the annex, see Chap. 12.1.5.

6.4 Analog Output

6.4.1 Setup

Setup occurs specific to the measurement program in the menu „Edit program“, see Chap. 12.1.5:

- „Enter offset for analog output“
- „Enter gain for analog output“

6.4.2 Measurement Conversion

The measurement value is calculated from the analog output voltage U_{OUT} as follows:

$$MV (mm) = \frac{3.4}{\text{Analog gain}} (U_{OUT} - \text{Analog offset})$$

Value ranges: Analog offset: -44.0000 V ... +44.0000 V
 Analog gain: -3.40000 ... +3.40000

The analog output voltage to be expected for a certain measurement value can be calculated from the following formula:

$$U_{OUT} (V) = \frac{MV (mm)}{3.4} * \text{Analog gain} + \text{Analog offset}$$

With the two quantities, analog gain and analog offset, you can produce all the arising linear output characteristics as shown in the following graph, see Fig. 42. This is particularly interesting for adaptation to evaluation equipment with lower resolution or lower voltage span on the input. In this respect, the above formula is changed according to the analog gain. Then it is possible, for example, to extend a measurement span of 10 mm (14 mm ... 34 mm) to a voltage span of ± 10 V; the analog gain in this case is +3.400.

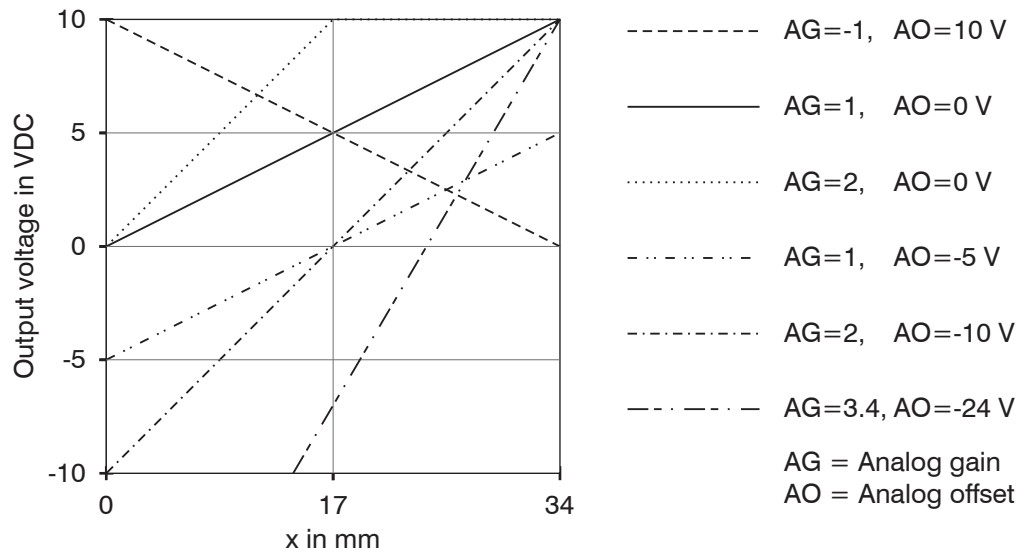

Fig. 42 Examples of the analog output scaling

• Zero setting, see Chap. 6.3.7.1 and mastering, see Chap. 6.3.7.2 also affect the analog output. It should therefore be carried out before the analog gain is changed.

The output voltage has an overrun respectively underrun of 20 mV (= 0.068 mm). This means it can exceed respectively undercut the zero point and the full scale (+10 VDC) by 20 mV in each case.

In the above example with AG = 2 and AO = 0 V the output voltage from an edge position x = 17 mm is limited to 10.02 V. With x > 34.034 mm the error value of 10.04 V then appears.

If negative output voltages are an irritation, an analog offset of -20 mV (-0.020 V) can be entered.

With „Error“ in the standard setting, a voltage of +10.04 V is output.

With input resistances less than 1 MOhm on the evaluation device, you must allow for a voltage division with the internal resistance of the analog output of 100 ohm. You can, however, also scale the analog output via the menu “Edit program” as has been described under “Display scaling” for the display.

For an internal resistance of, for example, 100 kohm a correction factor of 1.001 (+1 per thousand) arises and with 10 kohm the factor is already 1.010 (+1 %). From this you can estimate whether your application requires a correction. The settings „Offset“ and „Gain“ for the display and the analog output have no effect on the digital value.

• In the range „2-segment“ of the analog output remains shut down to 0 V.

6.4.3 Error Handling

In the menu „Select options“ you can decide under the point „Error handling, analog output“ whether with a possible error (e.g. no target in the measurement range) the last valid measurement is retained or the voltage 10.04 VDC is output.

This option is then also valid for the display, i.e. either the last valid measurement or ---.--- is displayed.

6.5 Synchronization of optoCONTROLS

➡ Connect the synchronizing signal output (signal +) of controller 1 with the synchronizing input (signal +) of controller 2 and proceed similarly with the minus pole.

Further systems can be added by cascading.

➡ Prefer screened leads for the synchronization.

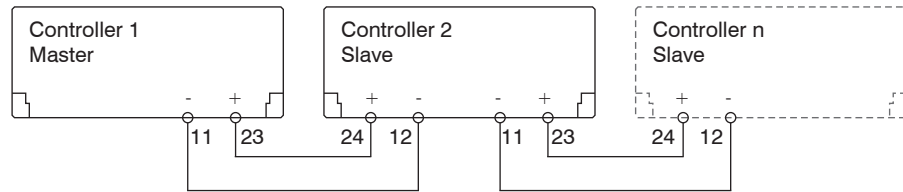

Inputs and outputs on the 25-pin Sub-D connector

Fig. 43 Synchronization of controllers

Measuring rate: 2.300 Hz

Synchron signal: 2.300 Hz

The synchronizing signal should be used for synchronization of two or more optoCONTROL 2500 only. The synchronization output is not designed for synchronization or triggering external measurement devices (PC boards).

The time offset between the synchronizing signals of master and slave is about 12 μ s.

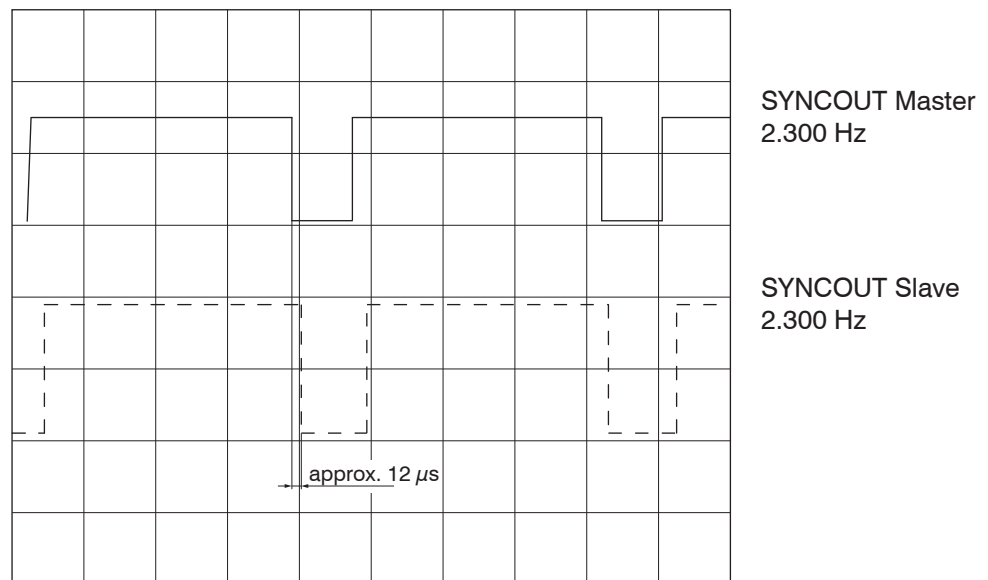

Fig. 44 Time offset through synchronizing signal

A synchronizing with the interface card IF2008 and SCD2500-x/IF2008 is alternatively possible as well.

6.6 Timing

The controller in the ODC 2500 operates internally in five cycles:

1. Integration: Gathering of the incoming light in the receiver (measurement),
2. Reading in: Conversion and saving of the light signals as digital values,
3. Computation: Measurement determination in the DSP (digital signal processor),
4. Controlling: Transfer of the measurements to the output controller where statistical computations (Segment, Min, Max, PtP, Limits, Zero-setting) are carried out,
5. Output: Output via the analog and digital interfaces, activation of limit switching functions.

Each cycle takes about $435 \mu\text{s}$ ($= 1 / \text{measuring rate}$). After five cycles in each case the measured value N is available on the output. The delay between the input reaction and output signal is $2175 \mu\text{s}$. The processing of the cycles occurs sequentially in time and parallel in space, see Fig. 45. After a further $435 \mu\text{s}$ the next measurement $N + 1$ is present on the output.

Cycle	1.	2.	3.	4.	5.	Time (μs)
Integration (measurement)	N	N+1	N+2	N+3	N+4	435
Reading in	N-1	N	N+1	N+2	N+3	870
Computation	N-2	N-1	N	N+1	N+2	1305
Controlling	N-3	N-2	N-1	N	N+1	1740
Output	N-4	N-3	N-2	N-1	N	2175

Fig. 45 Internal cycles in the ODC controller

6.7 Error Effects

6.7.1 Extraneous Light

A filter in the receiver provides a maximum suppression of extraneous light at 8,000 Lux outside of the reception range and 1,000 Lux for direct incident radiation from fluorescent lamps into the receiver.

Direct incident radiation onto the receiver from directional light sources, such as reflector lamps or sunlight, should be avoided. By employing suitable precautions (matt black screening panels, housing, etc.) it should be ensured that as little extraneous light as possible shines into the receiver. This also applies to changing light reflections and backgrounds (windows, lamps, persons, etc.).

- Avoid direct incident radiation into the receiving area.

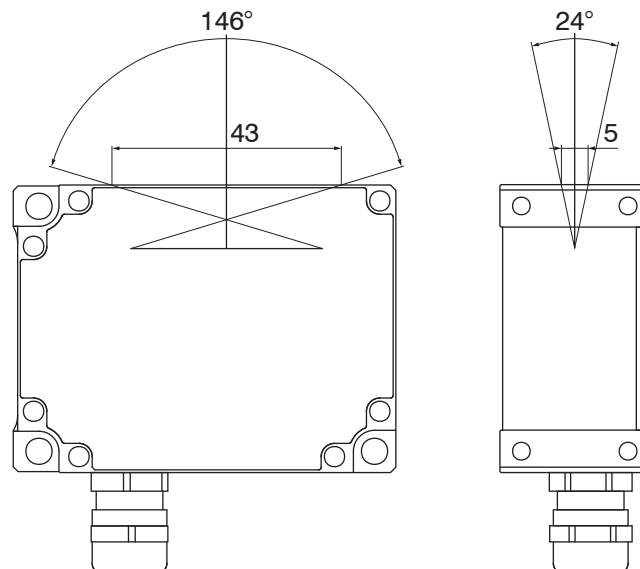

Fig. 46 Parts of the input area sensitive to extraneous light

6.7.2 Effects on the Light Beam



Fig. 47 Free space for the light beam between light source and receiver

In this free space no edges of closed-by objects must protrude.

The theoretical light sensitive range of the receiver is 34×0.005 mm. If a continuous run is to be sampled (e.g. cable diameter or truncated cone), then this can be realized with a theoretical lateral resolution of $5 \mu\text{m}$. For edge jumps and grooves apply features, since the laser light beam is affected by diffraction.

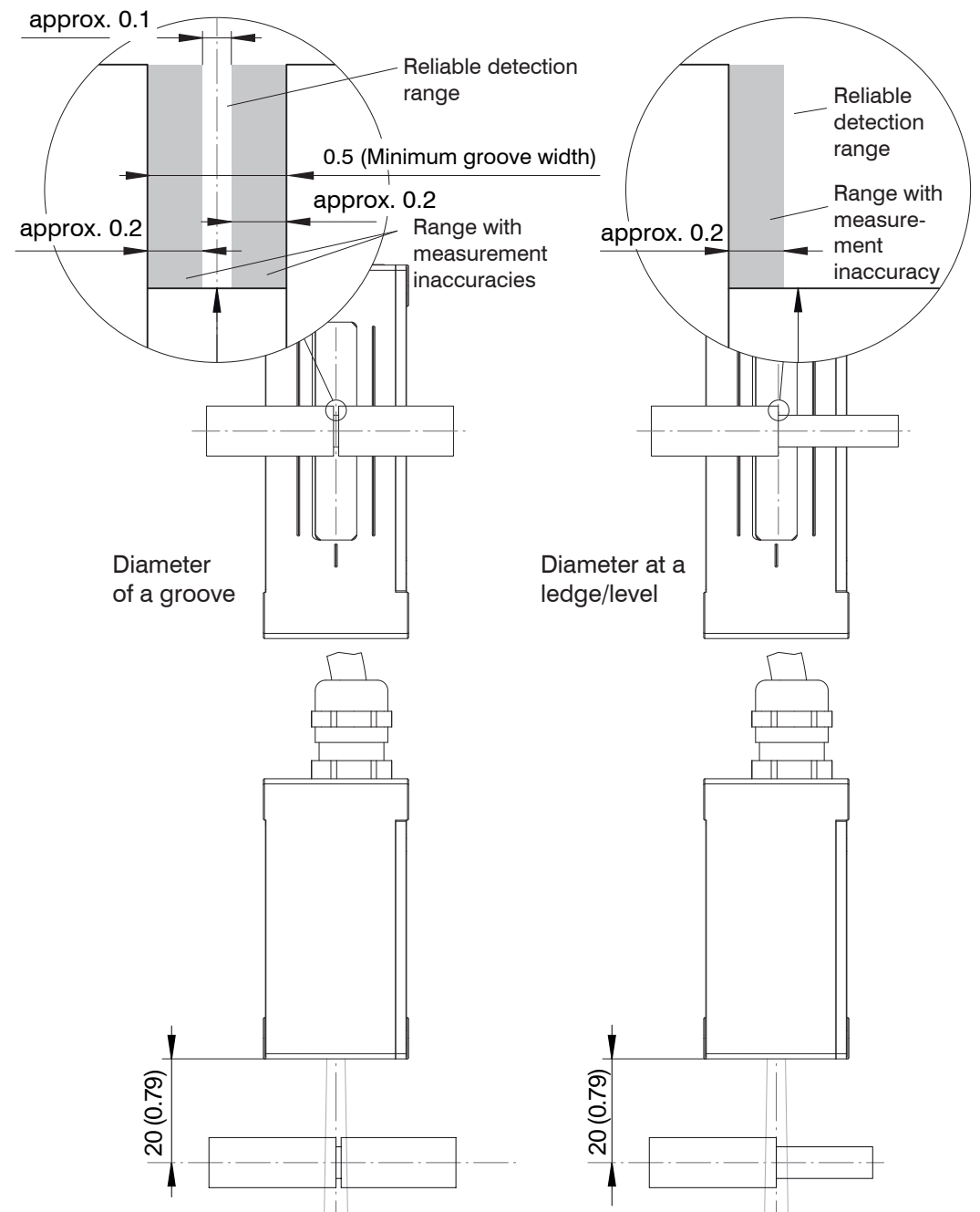

Fig. 48 Modifications in measurements of cut-ins and edge transitions

If the permissible distance range is exceeded, then the measurement error increases. Diffraction also limits the usable diameter / gap to a minimum of 0.5 mm.

If edges protrude into the light beam which are not used in the measurement process, then these must be taken into account (masked out) when editing the measurement program. Use the program „Segment“ for this. Here, you can freely select which edges are to be measured.

6.7.3 Contamination

All objects in the beam path throw a shadow. Avoid dust deposits in the measurement channel (receiver and light source). If possible, use the horizontal measurement arrangement.

In a dusty environment the receiver and the laser must be continuously blown off with cleaned (free of dust and oil) compressed air using a commercially available nozzle.

- Use a clean, soft, lint-free cloth and pure alcohol (isopropanol) for cleaning the protective windows.
- Never use normal window cleaning agents.

6.7.4 Transparent Targets

Although, due to its operating principle with parallel laser light, the measurement system can measure even very slight disturbances in the beam path, MICRO-EPSILON Eltotec GmbH recommends that tests are conducted when using transparent materials (e.g. edges of clear film and disks or transparent round material - glass tubes) at different measurement distances.

For the measurability assessment of transparent targets the video signal is also applicable, see Chap. 6.3.5.

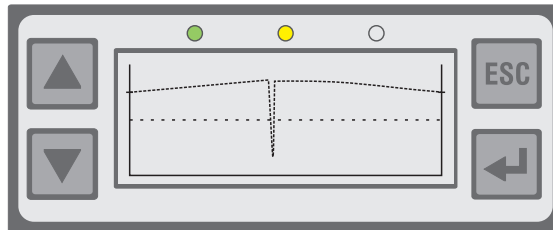

Fig. 49 Video signal with glass panel as target

Transparent targets not completely shade the laser light. Herein the edge of the glass entirely effects a little shading, which is enough for the determination of the edge position.

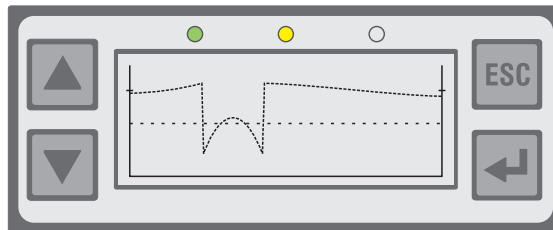

Fig. 50 Video signal with glass tube as target

The glass tube also operates as a cylindric lens. Thereby the range left and right of target is to be lightened besides.

The diameter is measurable well (Mastering).

The program „Diameter (DIA)“ should be preferred for thickness measurements, because here the first and last edges are used for the measurement of the outer diameter. In addition, extreme cleanliness should be observed.

Diffusely transparent material can be measured.

7. Digital Interface

7.1 Interface Parameters

One digital interface is available (RS422 or RS232). It is activated by selecting in the menu „Select options“ > „Select active interface“ and configured in the menu „Select RS232 parameters“ (or RS422). The data word (= one measurement) is composed of three consecutive bytes (L-byte, M-byte, H-byte).

The maximum measuring rate of the measurement system is only obtained with a baud rate of 115.2 kBaud or higher. With slower data transfer measurements are omitted. The relationship between the selected baud rate and the measuring rate is illustrated, see Fig. 51.

Baud rate (kBaud)	Measuring rate (Measurements/second)	
	RS232	RS422
691.2		x
115.2	x	
38.4	x	x
19.2	x	x
9.6	x	x

Fig. 51 Baud rates and measuring rates

RS232

Baud rate: 9.6 to 115.2 kBaud, selectable via menu „RS232 baud rate“
 Data format: 8 data bits, parity selectable, 1 or 2 stop bits, adjustable via menu „Select RS232 parameter“, (standard: 8,N,2)

RS422

Baud rate: 9.6 to 691.2 kBaud, selectable via menu „RS422 baud rate“
 Data format: 8 data bits, parity selectable, 1 or 2 stop bits adjustable via menu „Select RS422 parameters“ (standard: 8,N,1)

7.2 Data Conversion

Start	0	0	6 Bit (D5 ... D0)				Start	Stop	0	1	6 Bit (D11 ... D6)				Stop	Start	1	0	6 Bit (My ... D12)				Stop
-------	---	---	-------------------	--	--	--	-------	------	---	---	--------------------	--	--	--	------	-------	---	---	--------------------	--	--	--	------

Fig. 52 Transmission format of a data word (example)

L-Byte	0	0	D5	D4	D3	D2	D1	D0
--------	---	---	----	----	----	----	----	----

M-Byte	0	1	D11	D10	D9	D8	D7	D6
--------	---	---	-----	-----	----	----	----	----

H-Byte	1	0	My	Mx	D15	D14	D13	D12
--------	---	---	----	----	-----	-----	-----	-----

	My	Mx
Seg. 1	0	0
Seg. 2	0	1

Fig. 53 Measurement allocation for „2-segment“ operating mode

D15	D14	D13	D12	D11	D10	D9	D8	D7	D6	D5	D4	D3	D2	D1	D0
-----	-----	-----	-----	-----	-----	----	----	----	----	----	----	----	----	----	----

Fig. 54 Result of conversion (= digital value DV)

The following formula is used for the conversion of the digital values (DV) to the measurement values (MV in mm):

$$MV (mm) = DW * 34.4386 / 65519 - 0.2221$$

The settings „Offset“ and „Gain“ for the display or the analog output have no effect on the digital value.

With errors a digital value of > 65520 is output.

Error messages during measurement output:

65521	DSP	No edge
65522	DSP	At the beginning of the picture
65523	DSP	At the end of the picture
65524	DSP	Dark - bright edge
65525	DSP	Bright - dark edge
65526	DSP	Min. number of edges
65527	DSP	Max. number of edges
65528	DSP	Invalid measuring program
65529	DSP	Segment 1 st edge ≥ 2 nd edge
65530	DSP	Segment number of edges < last edge
65531	DSP	Invalid working distance
65533	ARM	Laser off
65534	ARM	Invalid float
65535	ARM	DMA setup error

7.3 Control Commands

Control commands are used for controlling the operation of the controller. The control commands for the sensor consist of command data which are interchanged in both directions.

Each command data packet consists of an integer multiple of 32-bit words. Since most serial interfaces use an 8-bit data format, four consecutive bytes are combined to form a 32-bit word.

Since most serial interfaces use an 8-bit data format, four consecutive bytes are combined to form a 32-bit word.

Each command has a header of two 32-bit words followed by the command and any further data (where required).

Byte 1	Byte 2	Byte 3	Byte 4
Header			
ID			
Command			
Data 1			
Data (n)			

Fig. 55 Structure of a command packet

The first word contains the header for identifying a connection to the sensor. The second word ID is used for identifying the sender. The third word is the actual command, where-by the upper two bits in Byte 2 are always „0“.

When the sensor receives a command, it is answered in that the command is returned with the MSB in Byte 2 set to „1“. If the sensor finds an error in executing the command, the second highest bit in Byte 2 is also set to „1“.

When the sensor responds to a command, no header is sent.

- The prefix 0x is the code for numbers in the hexadecimal format.
- l In the following commands the representation is given in the transmission sequence (Bytes 1 - 4) on the serial interface.

i The controller processes the data in the “Little Endian Format”.

Example: The 32-bit command word “INFO” 0x 0000 2011 has two contents:
 First part 0x2011: Command 16-bit variable in the controller
 Second part 0x0000: Length 16-bit variable in the controller

i The length figure from the PC gives the number of the following 32-bit words. In contrast, the controller of the ODC2500 sends a length figure corresponding to the number of 32-bit words in the complete data packet.

Consequently, the following 32-bit word must be transmitted sequentially over the interface:

0x11 0x20 0x00 0x00

i Byte-by-byte reading and out from left to right!

7.4 Commands

7.4.1 Overview

HexCode	Name	Importance
0x00002011	INFO	Information command (Indicates sensor data)
0x00002022	START	Permanent measurement output
0x00002021	STOP	Terminate measurement output
0x00002001	RESET	Reset and reboot
0x00012023	CHOOSE_MP	Change the current measurement program
0x00022024	SWITCH_EDGE	Change the edges to be measured in the segment measurement
0x00002033	RD_MINMAX	Read out the min/max values
0x00002034	RD_MINMAX_RESET	Read out the min/max values with reset
0x00002025	RD_OPT_RAM	Read the option data from the main memory
0x000B2027	WR_OPT_TO_RAM	Write the option data to the main memory
0x00002029	SAVE_OPT_RAM_TO_FLASH	Save the option data from the main memory to the flash memory
0x00002026	RD_MPR_RAM	Read the measurement program data from the main memory
0x000F2028	WR_MPR_TO_RAM	Write the measurement program data to the main memory
0x0000202A	SAVE_MPR_RAM_TO_FLASH	Save the measurement program data from the main memory to the flash memory

Fig. 56 ODC2500 commands

7.4.2 Information Command

Name: INFO
 Description: After the command response, sensor data are sent in the ASCII format

Command:

Byte 1	Byte 2	Byte 3	Byte 4	hex
"+"	"+"	"+"	0x0D	0x0D2B2B2B
"O"	"D"	"C"	"1"	0x3143444F
0x11	0x20	0x00	0x00	0x00002011

Response:

Byte 1	Byte 2	Byte 3	Byte 4	hex	Remark
"O"	"D"	"C"	"1"	0x3143444F	
0x11	0xA0	0x03	0x00	0x0003A011	Without error
0x11	0xE0	0x03	0x00	0x0003E011	With error + 4 bytes error code

Sensor data:

SerialNumber: `1234567` ASCII - 8 Byte
 Option: `000` ASCII - 8 Byte
 Measurement range [mm]: 34 Binary - 0x22000000
 Reserve: Binary - 0xDE83EB3D
 SoftArtBoot: `Std` ASCII - 4 Byte
 SoftArtArm: `Std` ASCII - 4 Byte
 SoftArtDSP: `Std` ASCII - 4 Byte
 SoftVersionBoot: 1003 Binary - 0xEB030000
 SoftVersionARM: 1006 Binary - 0xEE030000
 SoftVersionDSP: 1002 Binary - 0xEA030000

7.4.3 Start Command

Name: START
 Description: Starts the permanent measurement output of the sensor.

Command:

Byte 1	Byte 2	Byte 3	Byte 4	hex
"+"	"+"	"+"	0x0D	0x0D2B2B2B
"O"	"D"	"C"	"1"	0x3143444F
0x22	0x20	0x00	0x00	0x00002022

Response:

Byte 1	Byte 2	Byte 3	Byte 4	hex	Remark
"O"	"D"	"C"	"1"	0x3143444F	
0x22	0xA0	0x03	0x00	0x0003A022	Without error
0x00	0x00	0x00	0x00	0x00000000	With error (error code)

7.4.4 Stop Command

Name: STOP
 Description: Stops the permanent measurement output from the sensor

Command:

Byte 1	Byte 2	Byte 3	Byte 4	hex
"+"	"+"	"+"	0x0D	0x0D2B2B2B
"O"	"D"	"C"	"1"	0x3143444F
0x21	0x20	0x00	0x00	0x00002021

Response:

Byte 1	Byte 2	Byte 3	Byte 4	hex	Remark
"O"	"D"	"C"	"1"	0x3143444F	
0x21	0xA0	0x03	0x00	0x0003A021	Without error
0x00	0x00	0x00	0x00	0x00000000	Without error (error code)

- “Start” is on when the sensor is switched on. The command “Stop” is volatile and is lost when the voltage supply is switched off or the reset command is sent.

7.4.5 Reset Command

Name: RESET

Description: The sensor executes a software reset. This corresponds to switching the sensor off and then on again.

Command:

Byte 1	Byte 2	Byte 3	Byte 4	hex
“+”	“+”	“+”	0x0D	0x0D2B2B2B
“O”	“D”	“C”	“1”	0x3143444F
0x01	0x20	0x00	0x00	0x00002001

Response:

Byte 1	Byte 2	Byte 3	Byte 4	hex	Remark
“O”	“D”	“C”	“1”	0x3143444F	
0x01	0xA0	0x02	0x00	0x0002A001	Without error

7.4.6 Change the Measurement Program

Name: CHOOSE_MP

Description: The sensor changes the current measurement program. This corresponds to selecting the measurement program via the display without the options of saving, i.e. after switching the sensor off and on the last saved measurement program is loaded.

Command:

Byte 1	Byte 2	Byte 3	Byte 4	hex	Remark
“+”	“+”	“+”	0x0D	0x0D2B2B2B	
“O”	“D”	“C”	“1”	0x3143444F	
0x23	0x20	0x01	0x00	0x00012023	Command, following length (32-bit-words)
0x02	0x00	0x00	0x00	0x00000002	0 ... EDGEHL 1 ... EDGELH 2 ... DIA 3 ... GAP 4 ... SEG_2_4 5 ... 2-SEG 6 ... USER1 7 ... USER2 8 ... USER3 9 ... USER4

Response:

Byte 1	Byte 2	Byte 3	Byte 4	hex	Remark
“O”	“D”	“C”	“1”	0x3143444F	
0x23	0xA0	0x03	0x00	0x0003A023	Without error
0x00	0x00	0x00	0x00	0x00000000	Error code

7.4.7 Change Edges (Segment and 2-Segment Programs)

Name: SWITCH_EDGE
 Description: If a Segment or a 2-Segment program is active on the sensor, then the edges to be measured are refreshed. After Power OFF the data last transmitted are lost.

Command:

Byte 1	Byte 2	Byte 3	Byte 4	hex	Remark
"+"	"+"	"+"	0x0D	0x0D2B2B2B	
"O"	"D"	"C"	"1"	0x3143444F	
0x24	0x20	0x02	0x00	0x00022024	Command, following length (32-bit-words)
0x01	0x03	0x00	0x00	0x00000301	Front edge Segment 1: 1 Segment 2: 3
0x07	0x05	0x00	0x00	0x00000507	Rear edge Segment 1: 7 Segment 2: 5

Response:

Byte 1	Byte 2	Byte 3	Byte 4	hex	Remark
"O"	"D"	"C"	"1"	0x3143444F	
0x23	0xA0	0x03	0x00	0x0003A023	Without error
0x00	0x00	0x00	0x00	0x00000000	Error code

7.4.8 Read Out Min / Max Values

Name: RD_MINMAX
 Description: After the command the controller transmits a min value and a max value in the range 0...65519.

Command:

Byte 1	Byte 2	Byte 3	Byte 4	hex
"+"	"+"	"+"	0x0D	0x0D2B2B2B
"O"	"D"	"C"	"1"	0x3143444F
0x33	0x20	0x00	0x00	0x00002033

Response:

Byte 1	Byte 2	Byte 3	Byte 4	hex	Remark
"O"	"D"	"C"	"1"	0x3143444F	
0x33	0xA0	0x04	0x00	0x0004A033	Without error
0x33	0xE0	0x03	0x00	0x0003E033	With error (+ 4 bytes error code)

Min [0 ... 65519]: Binary - 0x00008B3E
 Max [0 ... 65519]: Binary - 0x00008B4B
 Min/Max [mm] = Min/Max [0 ... 65519] * 34.4386 / 65519 - 0.2221

7.4.9 Read Out Min / Max Values Followed by Reset

Name: RD_MINMAX_RESET
 Description: After the command the controller transmits a min value and a max value in the range 0...65519. Then the min/max content is set to zero.

Command:

Byte 1	Byte 2	Byte 3	Byte 4	hex
"+"	"+"	"+"	0x0D	0x0D2B2B2B
"O"	"D"	"C"	"1"	0x3143444F
0x34	0x20	0x00	0x00	0x00002034

Response:

Byte 1	Byte 2	Byte 3	Byte 4	hex	Remark
"O"	"D"	"C"	"1"	0x3143444F	
0x34	0xA0	0x04	0x00	0x0004A034	Without error
0x34	0xE0	0x03	0x00	0x0003E034	With error (+ 4 bytes error code)

Min [0 ... 65519]: Binary - 0x00008B3E

Max [0 ... 65519]: Binary - 0x00008B4B

Min/Max [mm] = Min/Max [0 ... 65519] * 34.4386 / 65519 - 0.2221

7.4.10 Read Option Data

Name: RD_OPT_RAM

Description: With this command the currently valid option data are read out from the main memory.

Command:

Byte 1	Byte 2	Byte 3	Byte 4	hex
"+"	"+"	"C"	0x0D	0x0D2B2B2B
"O"	"D"	"C"	"1"	0x03143444F
0x25	0x20	0x00	0x00	0x00002025

Response:

Byte 1	Byte 1	Byte 1	Byte 1	hex	Remark
"O"	"D"	"C"	"1"	0x3143444F	
0x25	0x20	0x00	0x00	0x000DA025	Without error
0x25	0xE0	0x03	0x00	0x0003E025	With error (+ 4 bytes error code)

Measurement program number	Binary - 0x0000	Std. - Measurement program EDGEHL
Language	Binary - 0x0001	English
Displayed measurement unit	Binary - 0x0000	mm
Error handling, analog	Binary - 0x0000	Error output
Reserve1	Binary - 0x0000	
External laser switch-off	Binary - 0x0000	not active
Laser intensity	Binary - 0x0032	50 %
Contrast	Binary - 0x0032	50 %
Reserve2	Binary - 0x0000	
Active Interface	Binary - 0x0001	RS232
RS232 Baud rate	Binary - 0x0001C200	115200 Bd
RS232 Parity	Binary - 0x0000	None
RS232 Stop bits	Binary - 0x0002	2
RS232 TimeOut Transmit	Binary - 0x0001	No effect
RS232 TimeOut Receive	Binary - 0x0001	No effect
RS422 Baud rate	Binary - 0x000A8C00	691200 Bd
RS422 Parity	Binary - 0x0000	None
RS422 Stop bits	Binary - 0x0002	2
RS422 TimeOut Transmit	Binary - 0x0001	No effect
RS422 TimeOut Receive	Binary - 0x0001	No effect

7.4.11 Write Option Data

Name: WR_OPT_TO_RAM
 Description: With this command option data are written from the receive buffer to the main memory.
 The validity of the data is checked while this occurs. If incorrect data are found or a different error arises, the data are not accepted into the main memory.

Command:

Byte 1	Byte 2	Byte 3	Byte 4	hex
"+"	"+"	"+"	0x0D	0x0D2B2B2B
"O"	"D"	"C"	"1"	0x03143444F
0x27	0x20	0x0B	0x00	0x000B2027

Response:

Byte 1	Byte 1	Byte 1	Byte 1	hex	Remark
"O"	"D"	"C"	"1"	0x3143444F	
0x29	0xA0	0x03	0x00	0x0003A029	Without error
0x00	0x00	0x00	0x00	0x00000000	Error code

Possible error codes:

- 0x00000004 Too much data received
- 0x0000000A Error on writing to the RAM
- 0x0000000B Incorrect data transmitted, see Fig. 57 „Valid values“
- 0x0000000C Incorrect measurement program number

i If an error occurs, the data are not accepted!

Description	Format / Type	Bits	Valid values	Remark
Measurement program number	Binary unsigned short	16	0 ... 5, Standard 6 ... 9, User - if available in flash memory	6 - USER1 ... 9 - USER4
Language	Binary unsigned short	16	0, 1	0 ... German 1 ... English
Displayed measurement unit	Binary unsigned short	16	0, 1	0 ... mm 1 ... inch
Error handling Display + Analog output	Binary unsigned short	16	0, 1	0 ... Error output: --,--- 10.04 V 1 ... retain last value
Reserve1	Binary unsigned short	16		
External laser switch-off	Binary unsigned short	16	0, 1	0 ... not active 1 ... active
Laser intensity	Binary unsigned short	16	No effect The factory data are accepted.	
Contrast	Binary unsigned short	16	0 ... 100	0 ... 100 %
Reserve2	Binary unsigned short	16		
Active serial interface	Binary unsigned short	16	0, 1	0 ... RS422 1 ... RS232
RS232 Baud rate	Binary integer	32	9600, 19200, 38400, 115200	
RS232 Parity	Binary unsigned short	16	0, 1, 2,	0 ... No 1 ... Even 2 ... Odd
RS232 Stop bits	Binary unsigned short	16	1, 2	
RS232 Timeout transmission	Binary unsigned short	16	No effect The factory data are accepted.	

RS232 Timeout receipt	Binary unsigned short	16	No effect The factory data are accepted.	
RS422 Baud rate	Binary unsigned short	32	9600, 19200, 38400, 115200, 691200	
RS422 Parity	Binary unsigned short	16	0, 1, 2	0 ... No 1 ... Even 2 ... Odd
RS422 Stop bits	Binary unsigned short	16	1, 2	
RS422 Timeout transmission	Binary unsigned short	16	No effect The factory data are accepted.	
RS422 Timeout receipt	Binary unsigned short	16	No effect The factory data are accepted.	

Fig. 57 Option data record

7.4.12 Save Option Data

Name: SAVE_OPT_RAM_TO_FLASH
 Description: With this command the currently valid option data are written from the main memory to the flash memory.

Command:

Byte 1	Byte 2	Byte 3	Byte 4	hex
“+”	“+”	“+”	0x0D	0x0D2B2B2B
“O”	“D”	“C”	“1”	0x03143444F
0x29	0x20	0x00	0x00	0x00002029

Response:

Byte 1	Byte 1	Byte 1	Byte 1	hex	Remark
“O”	“D”	“C”	“1”	0x3143444F	
0x27	0xA0	0x03	0x00	0x0003A027	Without error
0x00	0x00	0x00	0x00	0x00000000	Error code

Possible error code: 0x00000006 Flash - access error

7.4.13 Read Measurement Program Data

Name: RD_MPR_RAM

Description: With this command the currently valid measurement program data are read out of the main memory.

Command:

Byte 1	Byte 2	Byte 3	Byte 4	hex
"+"	"+"	"+"	0x0D	0x0D2B2B2B
"O"	"D"	"C"	"1"	0x03143444F
0x26	0x20	0x00	0x00	0x000B2026

Response:

Byte 1	Byte 1	Byte 1	Byte 1	hex	Remark
"O"	"D"	"C"	"1"	0x3143444F	
0x26	0xA0	0x03	0x00	0x0003A026	Without error
0x26	0xE0	0x03	0x00	0x0003B026	With error + 4 bytes error code

Measurement program number	Binary -	0x0007	USER2- Measurement program
Measurement program name	ASCII -	0x45 0x44 0x47 0x45 0x48 0x4C 0x55 0x00	"E" "D" "G" "E" "H" "L" "U" Zero
Place-holder	Binary -	0x0000	
Analog offset	Binary -	0x00000000	0.0 VDC
Analog gain	Binary -	0x3F800000	1.0
Display offset	Binary -	0x00000000	0.0 mm
Display gain	Binary -	0x3F800000	1.0
High limit	Binary -	0x42080000	34.0 mm
Low limit	Binary -	0x00000000	0.0 mm
High warning	Binary -	0x42080000	34.0 mm
Low warning	Binary -	0x00000000	0.0 mm
Target distance	Binary -	0x0000	20 mm
Average for reading	Binary -	0x0001	1
Reserve	Binary -	0x0000	
Measurement program	Binary -	0x0001	edge HL
Front edge of Segment	Binary -	0x0000	
Rear edge of Segment	Binary -	0x0000	
Master value	Binary -	0x00000000	0.0 mm

7.4.14 Write Measurement Program Data

Name: WR_MPR_TO_RAM
Description: With this command measurement program data are written from the receive buffer to the main memory. The validity of the data is checked while this occurs. If incorrect data are found or a different error arises, the data are not accepted into the main memory.

Command:

Byte 1	Byte 2	Byte 3	Byte 4	hex
"+"	"+"	"+"	0x0D	0x0D2B2B2B
"O"	"D"	"C"	"1"	0x03143444F
0x28	0x20	0x0F	0x00	0x000F2028

Response:

Byte 1	Byte 1	Byte 1	Byte 1	hex	Remark
"O"	"D"	"C"	"1"	0x3143444F	
0x28	0xA0	0x03	0x00	0x0003A028	Without error
0x00	0x00	0x03	0x00	0x00000000	Error code

Possible errors:

0x00000004	Too much data received
0x0000000A	Error on writing to the RAM
0x0000000B	Incorrect data transmitted, see Fig. 58 "Valid values"

i If an error occurs, the data are not accepted!

Description	Format / Type	Bits	Valid values	Remark
Measurement program number	Binary unsigned short	16	6 ... 9	6 - USER1 9 - USER4
Measurement program name	ASCII char	8x8	"A" - "Z", " ", "_", "0" - "9"	Only uppercase letters. The last space characters are deleted. Space characters between the letters are replaced by "_" ("underscore").
Analog offset	Binary float	32	-10.000 ... +10.000	Entry is made in [VDC]
Analog gain	Binary float	32	-3.400 ... +3.400	
Display offset	Binary float	32	-99.999 ... +99.999	Entry is made in mm
Display gain	Binary float	32	-2.000 ... +2.000	
High limit	Binary float	32	-168.876	Entry is made in mm
Low limit	Binary float	32	...	
High warning	Binary float	32	...	
Low warning	Binary float	32	+168.876	
Distance target camera	Binary unsigned short	16	0, 1, 2, 3	0 ... 20 mm 1 ... 50 mm 2 ... 100 mm 3 ... 150 mm
Average for reading	Binary unsigned short	16	1 ... 4096	1 ... 128 sliding 129 ... 4096 recursive
Reserve	Binary unsigned short	16	No effect The factory data are accepted.	

Measurement program	Binary unsigned short	16	1 ... 6	1 ... EDGEHL 2 ... EDGELH 3 ... DIA 4 ... GAP 5 ... SEG_2_4 6 ... 2-EG
Front edge segment 1 + 2 1. Segment 2. Segment	Binary unsigned short Low-Byte High-Byte	16	1 ... 32 2 ... 32	Example: Front edge 1.Seg. = 2 Font edge 2.Seg. = 4 = 0x0402 hex (= 1026 decimal)
Rear edge segment 1 + 2 1. Segment 2. Segment	Binary unsigned short Low-Byte High-Byte	16	1 ... 32 2 ... 32	Example: Rear edge 1.Seg. = 8 Rear edge 2.Seg. = 7 = 0x0807 hex (= 1800 decimal)
Master value	Binary float	32	-34.000 ... +34.000	Entry is made in mm

Fig. 58 Measurement program data record

7.4.15 Save Measurement Program Data

Name: SAVE_MPR_RAM_TO_FLASH
 Description: With this command the currently valid measurement program data are written from the main memory to the flash memory.

Command:

Byte 1	Byte 2	Byte 3	Byte 4	hex
"+"	"+"	"+"	0x0D	0x0D2B2B2B
"O"	"D"	"C"	"1"	0x03143444F
0x2A	0x20	0x0F	0x00	0x0000202A

Response:

Byte 1	Byte 1	Byte 1	Byte 1	hex	Remark
"O"	"D"	"C"	"1"	0x3143444F	
0x2A	0xA0	0x03	0x00	0x0003A02A	Without error
0x00	0x00	0x00	0x00	0x00000000	Error code

Possible errors: 0x00000006 Flash - access error

7.4.16 Error Responses

- 0x04 Too much data received
- 0x06 Flash access error
- 0x0a Error on writing to the RAM
- 0x0b Incorrect data transmitted, see Fig. 58, "Valid values"
- 0x0c Incorrect measurement program number
- 0x01 Error destination, if μ C has to send information or data an error message is returned e.g. passing data to the DSP were aborted
- 0x02 Error source, error during data fetching
- 0x03 Error length, stated length in the parameter > buffer size receiver
- 0x05 Not used
- 0x07 Error erase flash
- 0x08 Error flash sector, during writing or deletion of the flash
- 0x09 Error video, video can not be fetched by the DSP

8. Accessories

The following accessory parts are optionally available for the optoCONTROL 2500 from MICRO-EPSILON Eltrotec GmbH:

- PS2020 power supply unit 24 VDC (for mounting on DIN top-hat rails)
- PC2500-3 or -10 power supply cable, 3 m or 10 m long
- CE1800-3 or -8 sensor cable extension 3 m or 8 m for receiver
- CE2500-3 or -8 sensor cable extension 3 m or 8 m for light source
- SCA2500-3, signal output cable 3 m for analog and switching outputs
- SCD2500-3/10/ RS422, signal output cable 3 m for analog and switching outputs and 10 m long for RS422
- SCD2500-3/3/ RS232, signal output cable 3 m for analog and switching outputs and 3 m long for RS232
- SCD2500-x/IF2008, interface and power cables for use with the card IF2008
- SCD2500-x/CSP, power and output cable for connection to the universal controller CSP2008
- IF 2008, interface card for up to four sensors plus two encoder
- CSP2008, universal controller for displacement signals

9. Warranty

All components of the device have been checked and tested for perfect function in the factory.

In the unlikely event that errors should occur despite our thorough quality control, this should be reported immediately to MICRO-EPSILON Eltrotec GmbH.

The warranty period lasts 12 months following the day of shipment. Defective parts, except wear parts, will be repaired or replaced free of charge within this period if you return the device free of cost to MICRO-EPSILON Eltrotec GmbH.

This warranty does not apply to damage resulting from abuse of the equipment and devices, from forceful handling or installation of the devices or from repair or modifications performed by third parties. No other claims, except as warranted, are accepted. The terms of the purchasing contract apply in full.

MICRO-EPSILON Eltrotec GmbH will specifically not be responsible for eventual consequential damages. MICRO-EPSILON Eltrotec GmbH always strives to supply the customers with the finest and most advanced equipment. Development and refinement is therefore performed continuously and the right to design changes without prior notice is accordingly reserved.

For translations in other languages, the data and statements in the German language operation manual are to be taken as authoritative.

10. Service, Repair

In the event of a defect in the controller, light source, receiver or the sensor cable, the complete system must be sent back for repair or replacement.

In the case of faults the cause of which is not clearly identifiable, the whole measuring system must be sent back to

MICRO-EPSILON Eltrotec GmbH
Heinkelstraße 2
73066 Uhingen / Germany

Tel: +49 (0) 7161 / 98872-300
Fax: +49 (0) 7161 / 98872-303
eltrotec@micro-epsilon.de
www.micro-epsilon.com

11. Decommissioning, Disposal

- ➡ Disconnect the power supply and output cable on the controller.
- ➡ Disconnect the sensor cable between light source, receiver and controller.

The disposal is done according to the legal regulations (see directive 2002/96/EC).

12. Annex

12.1 Operating Menu

12.1.1 Initialization and Operation in the Measurement Mode

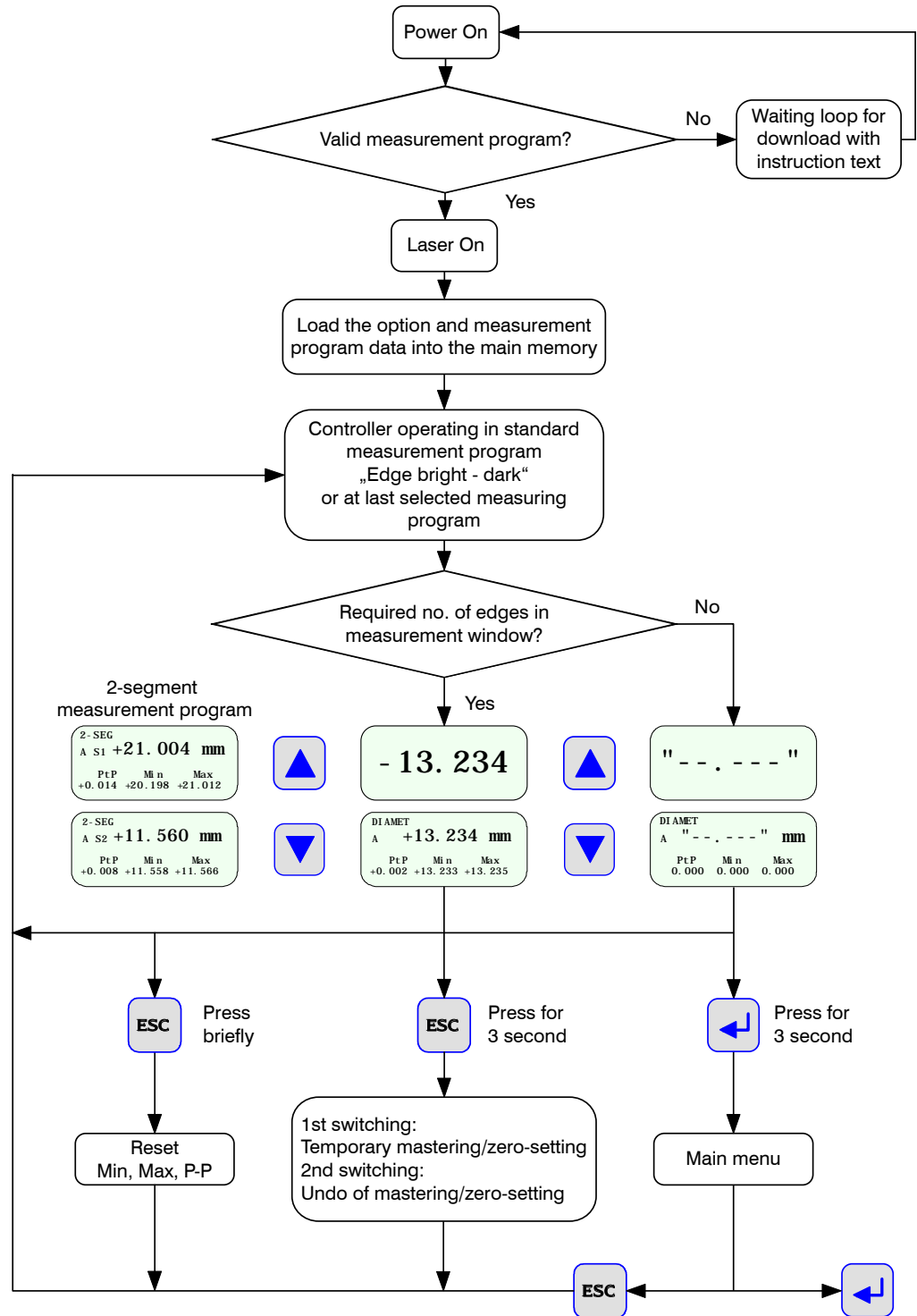

Fig. 59 Initialization and operation in the measurement mode

12.1.2 Dialog and Procedure for Saving

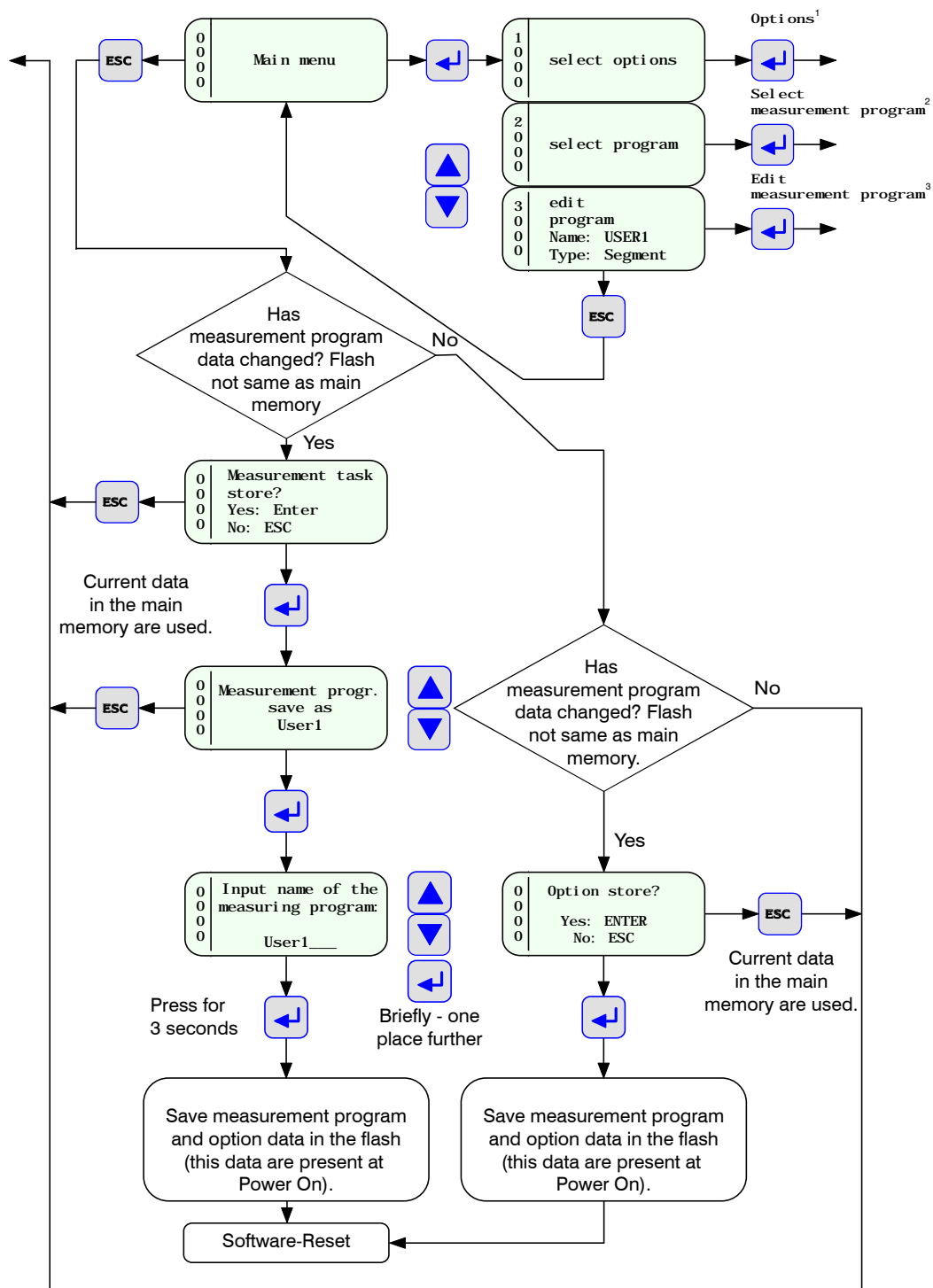

Fig. 60 Dialog and procedure for saving

1), see Chap. 12.1.3

2), see Chap. 12.1.4

3), see Chap. 12.1.5

12.1.3 Option (General Settings)

Grey fields require a selection.
Dark bordered boxes require you to enter a value.

Select options	Select contrast	Percentage for contrast		New value is immediately applied to the display.	
	Select language	English / German		The language change is immediately applied in the controller.	
	Select dimension for displayed reading	mm / inch (in)			
	Error handling reading analog output	Hold last value / Error		The latest value given can be displayed on the display / analog output by using "remain with latest measuring value". The voltage 10.04 V is given "Error" on the analog output or on the display ---,---	
	Select RS232 parameter	Baud Rate	9600 / 19200 / 38400 / 115200		Selection of the data transfer rate.
		Parity	none / even / Odd		
		Stop bit	1 / 2		
	Select RS422 parameter	Baud Rate	9600 / 19200 / 38400 / 115200 / 691200		Selection of the data transfer rate.
		Parity	none / even / Odd		
		Stop bit	1 / 2		
	Select active interface	RS422 / RS232			
	Select external laser control	active / not active		In the case of an active external laser controlling a switching input in order to switch the laser in the light source on/off can be used, see Chap. 5.5, see Chap. 5.7	
	Clear user data options + program data	yes = Enter no = ESC		Deletes user-defined programs. Get back to factory settings. Controller displays the active measuring value after finishing.	
Video				Gives the raw signal of the receiver on the display, see Chap. 6.3.5.	
Service menu	Software version		Shows various versions in the controller.		
	Laser setting		(Only for manufacturer)		
	Test switching outputs		Alternately activates the switching outputs of error, warnings and limits on the 25-pin Sub-D connector.		

The parameters which can be selected in the options are read out of the option data in the main memory and written back. The user can decide only on quitting the main menu whether the parameters are to be written into the flash memory. The data are then also present after Power ON.

The option data located in the main memory are used for the measurement mode. The currently set parameter appears first during selection.

12.1.4 Selecting the Measurement Program

Selecting the measurement program	Name: EDGEHL Standard edge bright - dark	
	Name: EDGELH Standard edge dark - bright	
	Name: DIA Standard width / diameter	
	Name: GAP Standard gap	
	Name: SEG_2_4 Standard segment edge 2 - 4 Controller differs max. 32 edges	
	Name: 2-SEG Standard 2-segment Controller differs max. 32 edges	1. Segment
		2. Segment
Name: USER1		
Name: USER2		
Name: USER3		
Name: USER4		

During selection the measurement program entered in the option data in the main memory is always shown first. In order that the selected measurement program is active after Power ON, it must be saved on quitting the menu mode. Otherwise, it is only active until the device is switched off. The measurement program name appears in the „Full Display“ measurement display mode for checking in the display.

i The measurement program name must be regarded as a comment and not as a search criterion, i.e. multiple use of the same name is not evaluated.

A maximum of four user programs can be saved. They can be overwritten.

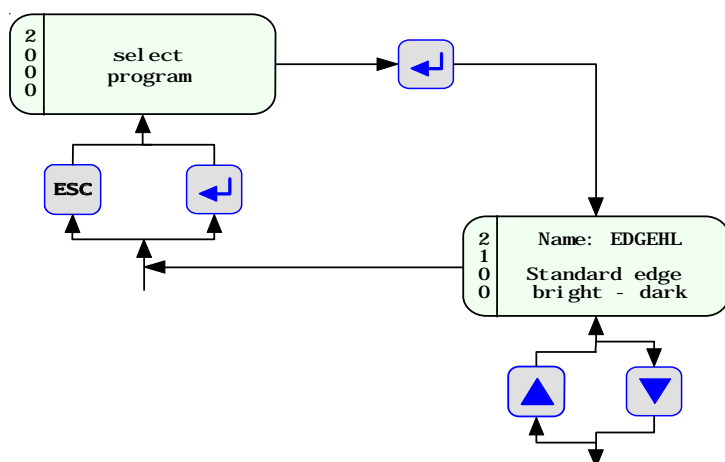

Fig. 61 Select measurement program

12.1.5 Editing the Measurement Program

		Measurement program editing					
		bright - dark	dark - bright	Width / Diameter	Gap	Segment 2 - 4	2-Segment
Name		EDGEHL	EDGELH	DIA	GAP	SEG_2_4	2-SEG
Segment		not active	not active	not active	not active	active	active
1	Leading edge					2	1
	Trailing edge					4	2
2	Leading edge					-	3
	Trailing edge					-	4
Master value		±34.000 mm	±34.000 mm	±34.000 mm	±34.000 mm	±34.000 mm	-
Display offset		±99.999 mm	±99.999 mm	±99.999 mm	±99.999 mm	±99.999 mm	-
Display gain		±2.000	±2.000	±2.000	±2.000	±2.000	-
Offset analog output		±44.000 VDC	±44.000 VDC	±44.000 VDC	±44.000 VDC	±44.000 VDC	-
Gain analog output		±3.400	±3.400	±3.400	±3.400	±3.400	-
High warning level (High WL 1 st segment)		±168.876 mm	±168.876 mm	±168.876 mm	±168.876 mm	±168.876 mm	±168.876 mm
Low warning level (Low WL 1 st segment)		±168.876 mm	±168.876 mm	±168.876 mm	±168.876 mm	±168.876 mm	±168.876 mm
High warning level (High WL 2 nd segment)		±168.876 mm	±168.876 mm	±168.876 mm	±168.876 mm	±168.876 mm	±168.876 mm
Low warning level (Low WL 2 nd segment)		±168.876 mm	±168.876 mm	±168.876 mm	±168.876 mm	±168.876 mm	±168.876 mm
Distance target - receiver		20 / 50 / 100 / 150 mm	20 / 50 / 100 / 150 mm	20 / 50 / 100 / 150 mm	20 / 50 / 100 / 150 mm	20 / 50 / 100 / 150 mm	20 / 50 / 100 / 150 mm
Moving averaging for N		1 ... 128	1 ... 128	1 ... 128	1 ... 128	1 ... 128	1 ... 128
Recursive averaging for N		129 ... 4096	129 ... 4096	129 ... 4096	129 ... 4096	129 ... 4096	129 ... 4096

Fig. 62 Measuring ranges program parameter

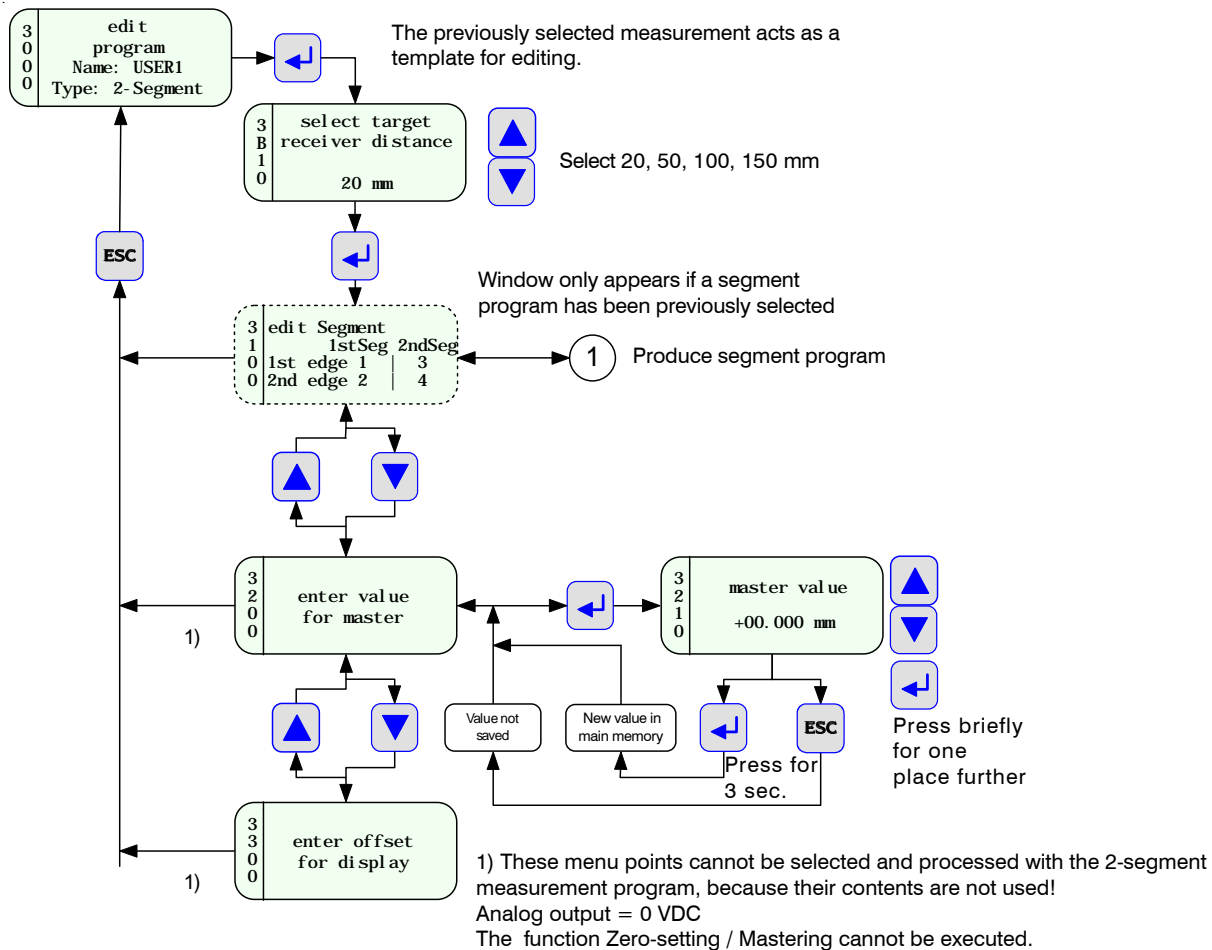
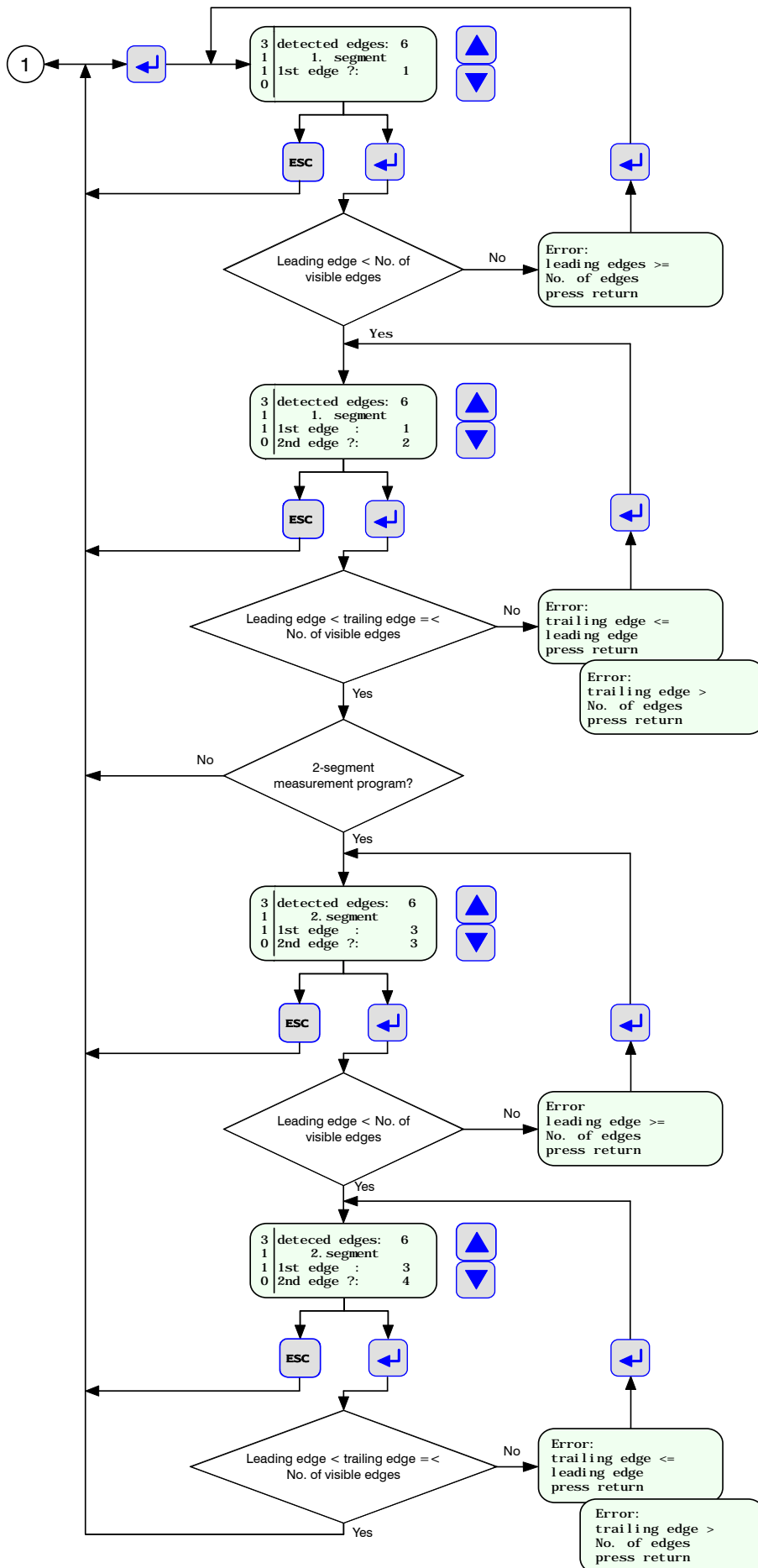

Fig. 63 Editing the measurement program

12.1.6 Generate a Segment Program



The front edge can also be set equal to zero; then measurement takes place from the zero-point of the receiver.

Fig. 64 Producing a segment program, flow chart
optoCONTROL 2500

12.2 Default Procedure

1000	Options	On delivery	Customer
	Contrast %	50	
	Language	English	
	Unit in measurement display	mm	
	Analog output for error	Error	
	RS232		
	Baud rate	115.200	
	Parity	None	
	Stop bits	2	
	RS422		
	Baud rate	691.200	
	Parity	None	
	Stop bits	1	
	Active interface	RS232	
	External laser control	Not active	
2000	Measurement program after Power ON	Standard edge EDGEHL (bright - dark)	

Name	bright - dark	dark - bright	Width / Diameter	Gap	Segment 2 - 4	2-Seg-ment	USER1	USER2	USER3	USER4
Segment	EDGEHL	EDGEHL	DIA	GAP	SEG_2_4	2-SEG	User-defined	User-defined	User-defined	User-defined
	Not active	Not active	Not active	Not active	Active	Active				
1					2	1				
	Leading edge				4	2				
	Trailing edge				-	3				
2					-	4				
	Leading edge									
	Trailing edge									
Master value	[mm]	+00.000	+00.000	+00.000	+00.000	-				
Display offset	[mm]	+00.000	+00.000	+00.000	+00.000	-				
Display gain		+1.000	+1.000	+1.000	+1.000	-				
Offset analog output	[VDC]	+00.000	+00.000	+00.000	+00.000	-				
Gain analog output		+1.000	+1.000	+1.000	+1.000	-				
High warning (High WL 1st segment)	[mm]	+034.000	+034.000	+034.000	+034.000	+034.000				
Low warning (Low WL 1st segment)	[mm]	+000.000	+000.000	+000.000	+000.000	+000.000				
High warning (High WL 2nd segment)	[mm]	+034.000	+034.000	+034.000	+034.000	+034.000				
Low warning (Low WL 2nd segment)	[mm]	+000.000	+000.000	+000.000	+000.000	+000.000				
Target distance	[mm]	20	20	20 mm	20	20				
Number of measuring values for averaging		1	1	1	1	1				

The return to the factory settings in the Options menu > Delete the custom option and measurement program data „available, see Chap. 12.1.3.



MICRO-EPSILON Eltrotec GmbH
Heinkelstraße 2 · 73066 Uhingen / Deutschland
Tel. +49 (0) 7161 / 98872-300 · Fax +49 (0) 7161 / 98872-303
eltrotec@micro-epsilon.de · www.micro-epsilon.com

X9751096-B041115GBR
© MICRO-EPSILON MESSTECHNIK

