



Instruction Manual
optoCONTROL 1202

optoCONTROL 1202-75
optoCONTROL 1202-100

Non-Contacting Laser-Micrometer

MICRO-EPSILON Eltrotec GmbH
Heinkelstraße 2

73066 Uhingen / Germany

Tel. +49 (0) 7161 / 98872-300
Fax +49 (0) 7161 / 98872-303
eltrotec@micro-epsilon.de
www.micro-epsilon.com



Certified acc. to DIN EN ISO 9001: 2008

Contents

1.	Safety	5
1.1	Symbols Used	5
1.2	Warnings	5
1.3	Notes on CE Identification	6
1.4	Proper Use	7
1.5	Proper Environment	7
2.	Laser Class	8
3.	Functional Principle, Technical Data	9
3.1	Functional Principle.....	9
3.2	Technical Data	10
4.	Delivery	12
4.1	Scope of Delivery, Unpacking.....	12
4.2	Storage	12
5.	Installation and Mounting	13
5.1	Sensor Mounting.....	13
5.2	Electrical Connections	16
5.2.1	Power Supply, Inputs and Outputs.....	18
5.2.2	Serial Interface	20
6.	Operation	21
6.1	Control- and Display Elements	21
6.2	Evaluation Mode	22
6.3	Analog Output	23
6.4	Limit Monitoring, Digital Outputs	24
6.5	External Triggering, IN0	25
6.6	RESET Function, IN1	26
6.7	TEACH Function, IN1	26
6.8	Software Tool.....	27
6.9	Sensor Mounting with Video Signal.....	28

7.	Calibration	29
8.	Warranty.....	29
9.	Service, Repair	29
10.	Decommissioning, Disposal	30
11.	Optional Accessories	30
12.	Factory Setting	30

1. Safety

The handling of the system assumes knowledge of the instruction manual.

1.1 Symbols Used

The following symbols are used in this instruction manual:



Indicates a hazardous situation which, if not avoided, may result in minor or moderate injury.



Indicates a situation which, if not avoided, may lead to property damage.



Indicates a user action.



Indicates a user tip.

1.2 Warnings

Caution - use of controls or adjustments or performance of procedures other than those specified herein may result in hazardous radiation exposure.



Connect the power supply and the display output device according to the safety regulations for electrical operating equipment.

- > Danger of injury
- > Damage to transmitter/ receiver

Avoid shock and knocks on the sensor and the controller.

- > Damage to transmitter/ receiver



Supply voltage must not exceed specified limits.

- > Damage to transmitter/ receiver

Protect connecting cable from damage.

- > Damage to transmitter/ receiver

Avoid damage (scratches) to the protective windows of the transmitter and receiver through unsuitable cleaning methods or cleaning solvents

> Inaccurate, erroneous measurements

Do not touch the protective windows of the laser and receiver with the fingers. Wipe off any fingerprints immediately.

> Inaccurate, erroneous measurements

Avoid permanent action of dust or splashed water on the measurement channel. Use protective housings.

> Damage to transmitter/ receiver

1.3 Notes on CE Identification

The following applies to optoCONTROL 1202: EMC regulation 2004/108/EC

Products which carry the CE mark satisfy the requirements of the EMC regulation 2004/108/EC 'Electromagnetic Compatibility' and the European standards (EN) listed therein.

The EU declaration of conformity is kept available according to EU regulation, article 10 by the authorities responsible at

MICRO-EPSILON Eltrotec GmbH

Heinkelstraße 2

D-73066 Uhingen

The system is designed for use in industry and satisfies the requirements of the standard EN 60947-5-2: 2007.

The measurement system fulfills the requirements when the guidelines described in the operating manual are observed during installation and operation.

1.4 Proper Use

- The optoCONTROL 1202 is designed for applications in the industrial field.
- It is used
 - for edge acquisition, width or diameter measurement, position acquisition of components or machine parts.
 - for measuring and testing problems in the process quality control
- The measuring system may only be operated within the limits specified in the technical data, see Chap. [3.2](#).
- Use it in such a way that with malfunctions or total failure of the sensor, persons are not endangered and machines are not damaged.
- Take additional precautions for safety and for damage prevention with safety-related applications.

1.5 Proper Environment

- Protection class
 - Electronics: IP 54
 - Optics: IP 67
- Operating temperature: -10 ... +50 °C (+14 to +122 °F)
- Storage temperature: -20 °C ... +85 °C (-4 to 185 °F)
- Humidity: 5 - 95 % (non condensing)
- Ambient pressure: Atmospheric pressure

2. Laser Class

The optoCONTROL 1202 sensor operates with a semiconductor laser with a wavelength of 670 nm (visible/red). The maximum optical output is ≤ 0.39 mW. The sensors are classified in Laser Class 1 (Class I). The accessible radiation is harmless under predictable conditions.

The following warning labels are attached to the cover of the sensor housing:



IEC label

Only for USA

Impairment of color vision and inconvenience may not be excluded for class 1 laser devices, e. g. through glare. Consequently, you can use Class 1 laser equipment without further protective measures.

Class 1 lasers are not subject to registration and a laser protection officer is not required.

The laser warning label for Germany is included in delivery. The version applicable to the user's country must be applied before the equipment is used for the first time.

i The housing of the transmitter and receiver may only be opened by the manufacturer! For repair and service purposes the sensors must always be sent to the manufacturer!

If both information labels are hidden in the installed state, the user must ensure that additional labels are fitted at the point of installation.

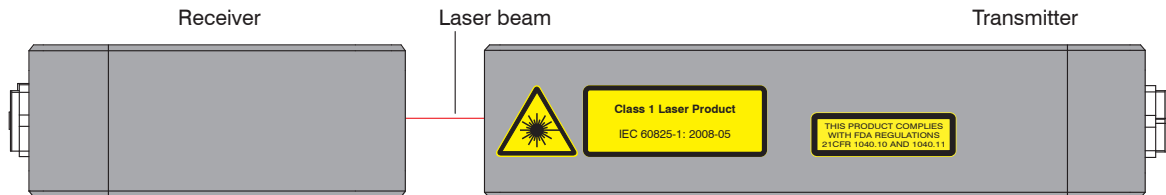

Fig. 1 True reproduction of the sensor with its actual location of the warning labels, view on top side

3. Functional Principle, Technical Data

3.1 Functional Principle

In the laser micrometers of the optoCONTROL series 1202 the laser beam is emitted from the optical transmitter unit as a laser line, that is as a parallel laser light with homogeneous light distribution, through suitable collimators and apertures. In the optical receiver unit the laser line impinges on a CCD line receiver. This CCD line comprises many closely adjacent individual receiver elements (pixels) that are arranged in a line. The light quantity of each of these receiver elements that is collected during the integration time can be separately read out as an analog voltage. After performing analog-digital conversion, it is stored in a data field as a digital value.

When there is a non-transparent measuring object in the laser line, the parallel laser light only illuminates those receiver elements (pixels) of the line that lies outside the shadow zone of the measuring object. As a result the pixels within the shadow zone give off a considerably lower analog voltage compared to the illuminated pixels. With suitable software algorithms the areas of the shadow zones can be determined from the previously stored data field. Since the distance of the pixels on the CCD line is known, the size and position of the measuring object can therefore be determined.



Fig. 2 Laser micrometer, series optoCONTROL 1202

The micro-controller of the ODC 1202 sensors can be parameterized through the serial RS232 interface by means of a Windows PC software:

- Setting the evaluation mode
- Setting the output polarity of the three digital outputs (OUT0, OUT1, OUT2)

The housing of the sensor features a TEACH/RESET button and a potentiometer for tolerance setting. Switching states are visualized by means of 4 LEDs which are integrated in the housing of the receiver.

Two digital inputs (IN0, IN1) make it possible to realize an external TEACH/RESET functionality and an external TRIGGER functionality through a PLC.

In addition the receiver features a high-speed analog output (0 ... 10 V) with 12-bit digital/analog resolution.

3.2 Technical Data

Model	optoCONTROL 1202-75	optoCONTROL 1202-100
Measuring range	typ. 72 mm	typ. 98 mm
Distance transmitter - receiver	min. 20 mm, max. 2,000 mm	
Resolution ¹	typ. 8 μ m	
Independent linearity	± 0.2 %	± 0.2 %
Repeatability	$\leq \pm 10$ μ m	
Sampling rate	max 400 Hz / 700 Hz (digital)	max 360 Hz / 600 Hz (digital)
Max. switching current	100 mA, short-circuit proof	
Interface	RS232, parameterisable under Windows	
Laser	Semiconductor laser 670 nm, 0.39 mW max. optical power, laser class 1 acc. to DIN EN 60825	
Optical filter	Interference filter, red light filter RG630, polarisation filter	
Housing material	Aluminium, anodized in black	
Housing dimensions (without flange female connector)	Transmitter: LxWxH approx. 130x125x30 mm Receiver: LxWxH approx. 75x125x30 mm	Transmitter: LxWxH approx. 170x145x30 mm Receiver: LxWxH approx. 70x145x30 mm

Model	optoCONTROL 1202-75	optoCONTROL 1202-100
Connector receiver	8-pin female connector type binder series 712 (SPS/Power) 4-pin female connector type binder series 707 (PC/RS232) 3-pin female connector binder series 712 (connection to the transmitter)	
Connector transmitter	3-pin female connector type binder 712 (connection to receiver)	
Connection cable	Connection to PC: PC1202-2/PC; connection to PLC: PC1202-2/PLC; connection cable transmitter/receiver: PC1202-2	
Teach button	Teach button at the housing for set point value teaching	
LED-indication	LED red (+): Measuring value > upper tolerance threshold LED green: Measuring value lies within tolerance threshold LED red (-): Measuring value < lower tolerance threshold LED yellow: multifunction	
Protection class	Elektronics: IP 54, optics: IP 67	
Operating temperature	-10 °C ... +50 °C (+14 °F +122 °F)	
Storage temperature	-20 °C ... +85 °C (-4 °F +185 °F)	
Output	Analog	Analog: 0 ... +10 V, max. 3 mA (12 bit)
	Digital	OUT0, OUT1, OUT2: pnp-bright-switching/npn-dark-switching or pnp-dark-switching/npn-bright-switching, adjustable under Windows, max. 100 mA, short-circuit proof
Digital input	IN0	External trigger, input voltage +Ub/0 V with protective circuit
	IN1	Teach/Reset, input voltage +Ub/0 V with protective circuit
Power supply	+15 VDC ... + 30 VDC, typ. 200 mA	
Sensitivity adjustment	under Windows via PC	
Laser adjustment	adjustable under Windows via PC	
EMC-checking	acc. to DIN EN 60947-5-2	

The quoted technical data apply for a displacement transmitter to receiver about 800 mm and a temperature of 20 °C (+68 °F).

1) Display resolution for both types: 10 μm

4. Delivery

4.1 Scope of Delivery, Unpacking

Check for completeness and shipping damage immediately after unpacking.

The delivery includes:

- | | |
|---------------------------|----------------------|
| 1 Transmitter ODC1202-x-T | 1 Instruction manual |
| 1 Receiver ODC1202-x-R | |
| 1 Test log | |

In case of damage or missing parts, please contact Micro-Epsilon Eltrotec or the supplier.

4.2 Storage

- Storage temperature: -20 ... +85 °C (-4 ... +185 °F)
- Humidity: 5 - 95 % (no condensation)

5. Installation and Mounting

The measurement system optoCONTROL 1202 is an optical system for measurements with μm accuracy. Make sure it is handled carefully when installing and operating.

5.1 Sensor Mounting

- ➡ Mount the transmitter and receiver above every the three through holes (dia. 4.5) or above every the two tapped blind holes M5.
- ➡ Pay attention that, when the transmitter and receiver are mounted freely, initially exact alignment of the housing edges with respect to one another should be ensured. The housing edges must lie within one plane.
- ➡ Use a try square or other suitable aids for alignment of transmitter and receiver.
- ➡ Pay attention on the alignment of target for avoiding measurement inaccuracies, see [Fig. 3](#)

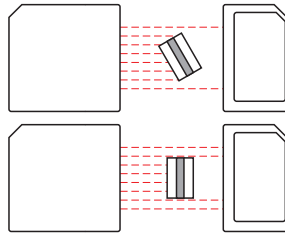

Fig. 3 Measurement inaccuracy at tilted targets

- ➡ Do not touch the optical windows. Contamination on the optical windows impairs correct functioning. The optional available mounting rail for fixing of transmitter and receiver allows operating distances up to 2,000 mm.
- ➡ Fix the mounting rail so that it is not bended respectively twisted.

- Minimum distance between transmitter and receiver: 20 mm
- Maximum distance between transmitter and receiver: 2,000 mm

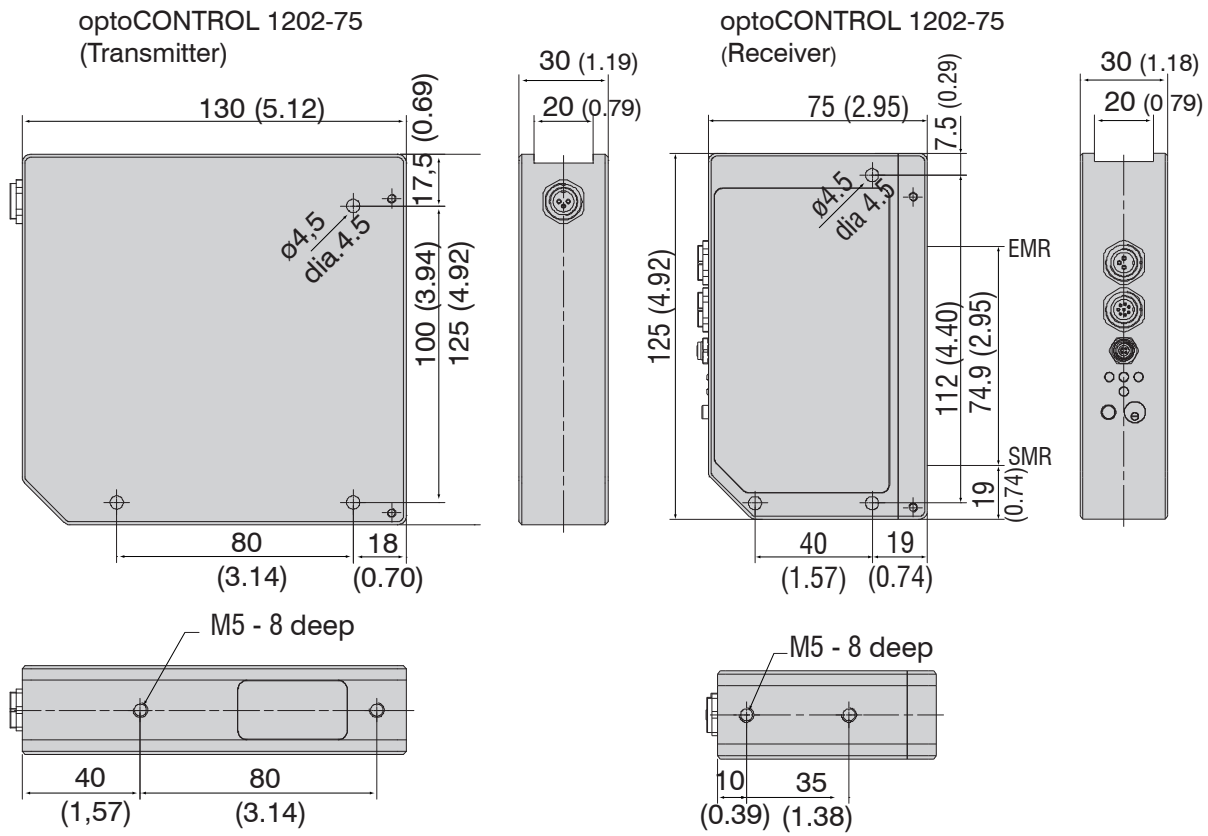

Fig. 4 Dimensional drawing optoCONTROL 1202-75, dimensions in mm (inches), not to scale

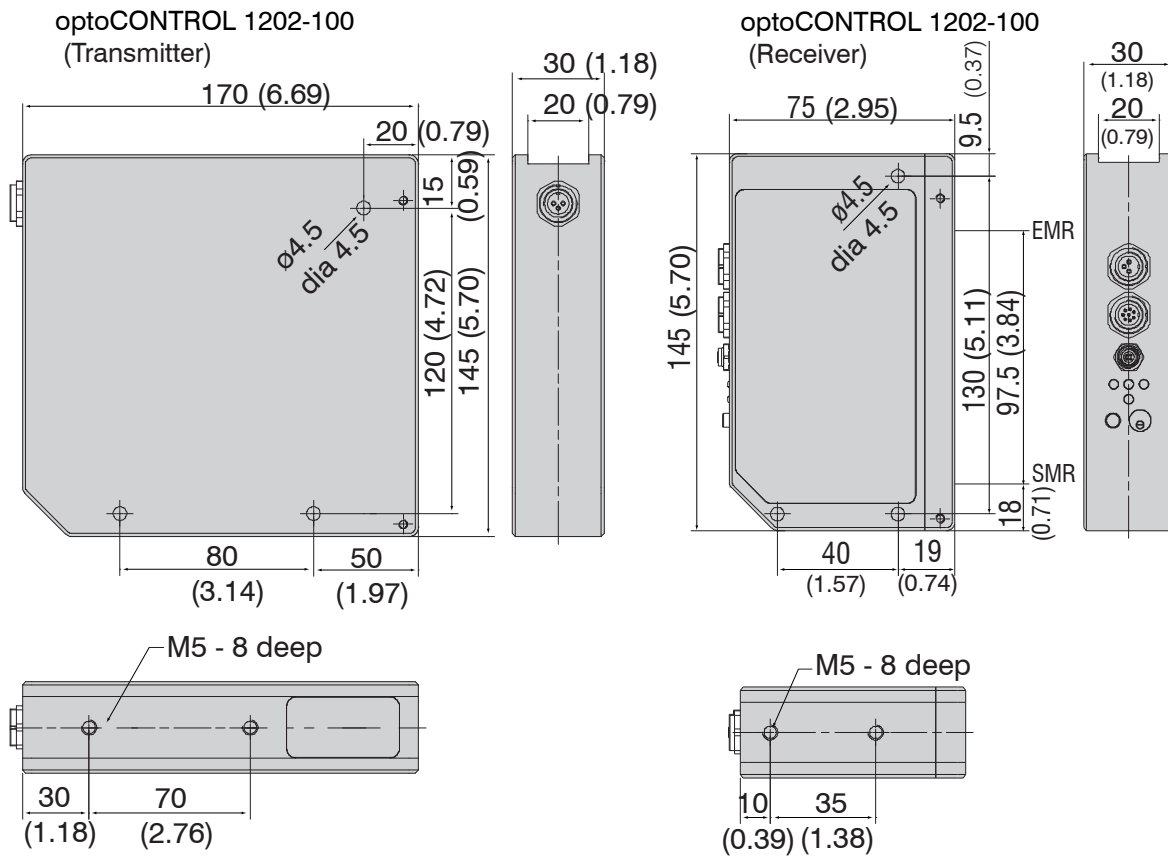

Fig. 5 Dimensional drawing, optoCONTROL 1202-100, dimensions in mm (inches), not to scale

5.2 Electrical Connections

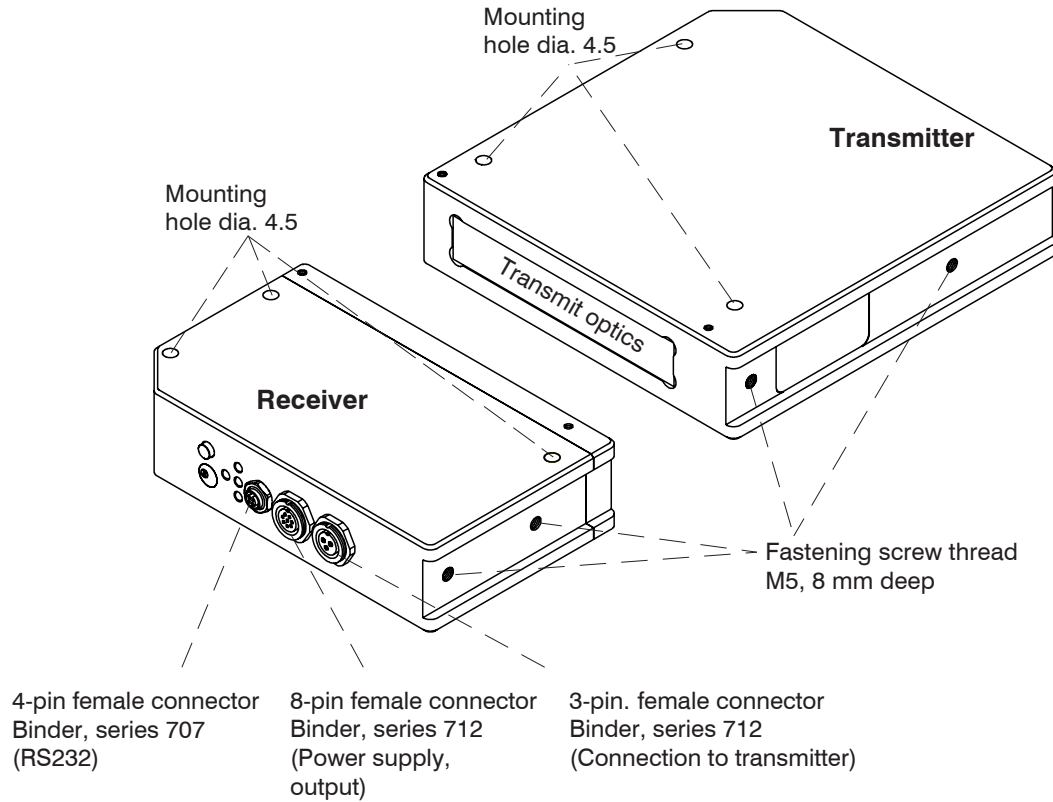

Fig. 6 Electrical connections of transmitter and receiver

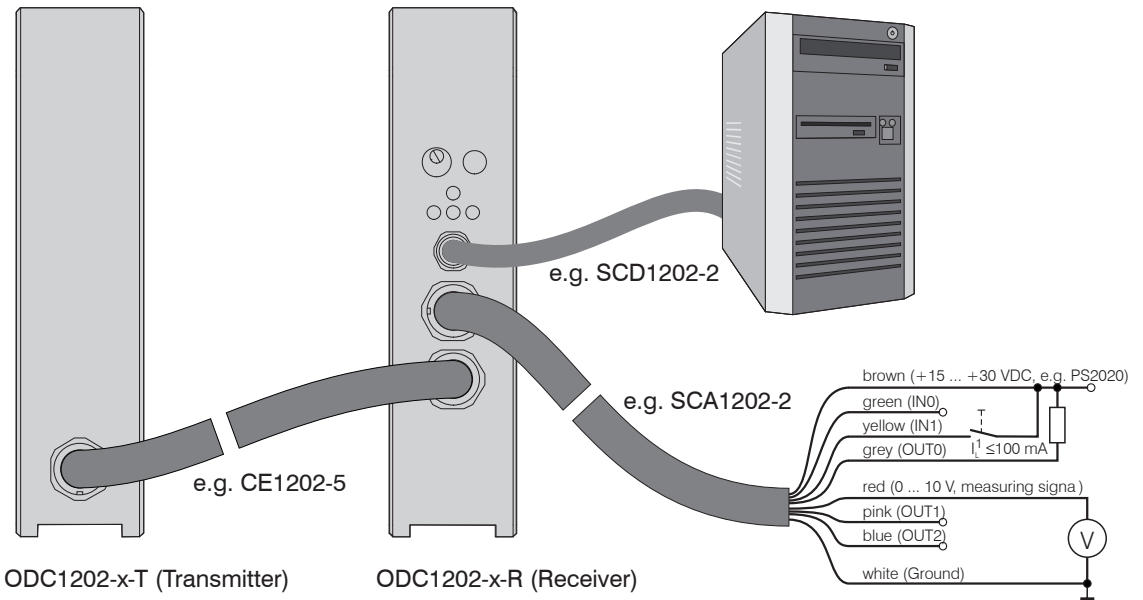

Fig. 7 Typical wiring of transmitter, receiver, control the digital input IN1 and the digital output OUT0

Bending radii cables:

SCD1202-x / SCA1202-x / CE1202-x: minimal 80 mm flexible or 53 mm fixed

1) High side/low side switch. Drives the load in direction to power supply or to ground.

5.2.1 Power Supply, Inputs and Outputs

The connections of power supply, inputs and outputs are effected via a 8-pin cable connector, Binder, series 712. As a matching part you require an adequate cable connector.

Different converted cables with open ends are optionally available.

The optional available power supply-/output cables SCA1202-x feature following bending radii:

- 53 mm (fixed),
- 80 mm (flexible).



Pin	Assignment	Color SCA1202-x	 View on solder-pin side male cable connector	
1	Ground (0 V)	white		
2	Power supply +15 ... +30 VDC	brown		
3	INO (External trigger)	green		
4	IN1 (Teach/Reset)	yellow		
5	OUT0 (-)	grey		
6	OUT1 (+)	pink		
7	OUT2 (OK)	blue		
8	Analog output (0 ... 10 V)	red		

Fig. 8 Pin- and color assignment for 8-pin male connector and output cable SCA1202-x

External Triggering, IN0

When a HIGH-pulse is applied at the digital input IN0, the external triggering (measuring value output) is set at the hardware.

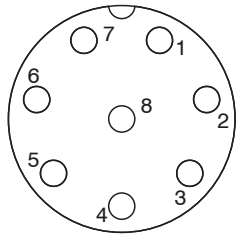
RESET-Function, IN1

When a HIGH-pulse of less than 750 ms duration is applied, the RESET function is performed at the receiver. This resets the current maximum and minimum values.

TEACH-Function, IN1

When a HIGH-pulse of more than 1.5 s duration is applied, the TEACH function is performed at the receiver.

Digital outputs OUT0 ... OUT2

Characteristics:

- High side/low side switch
- HIGH = +Ub (12 ... 32 VDC),
- LOW = 0 V,
- max. 0.1 A, short circuit proof

The polarity of the digital outputs can only be changed via the parameter „POLARITY“ in the software tool:

- POLARITY > DIRECT: Activated digital output is on +UB (+15 VDC ... +30 VDC),
- POLARITY > INVERSE: Activated digital output is on 0 V level.

5.2.2 Serial Interface

Characteristics:

- 3-line-connection: GND, TXD, RXD
- Speed: 19200 Baud
- 8 Data bits, no parity, 1 stop bit, binary, MSB first

The connection of the serial interface is effected via a 4-pin cable connector, Binder, series 707. As matching part you require an adequate cable connector.

Different converted cables are optionally available.

The optional available interface cables SCD1202-x feature following bending radii:

53 mm (fixed),

80 mm (flexible).

Pin 4-pin.	Assignment	 <p>View on solder side male cable connector</p>		Pin 9-pin. Sub-D	
1	Power supply			---	
2	Ground (0 V)			5	
3	TxD			2	
4	RxD			3	

Fig. 9 Pin assignment for 4-pin. male connector respectively SCD1202-x for connection to a PC

6. Operation

- ➡ Insulate all, not required cable ends at the power supply- and output cable before switching-on of the supply voltage. Therewith you avoid short circuits.
- ➡ Connect the cable connections according to the designated use.
- ➡ Check the screw connections at transmitter and receiver on attached hub.
- ➡ Switch on the supply voltage for the sensor. The yellow LED at the receiver flashes.
- ➡ Parameterize the sensor via the RS232/USB-interface.

6.1 Control- and Display Elements

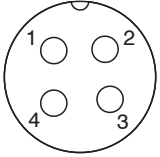
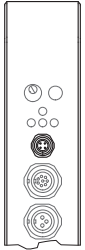
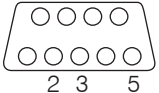
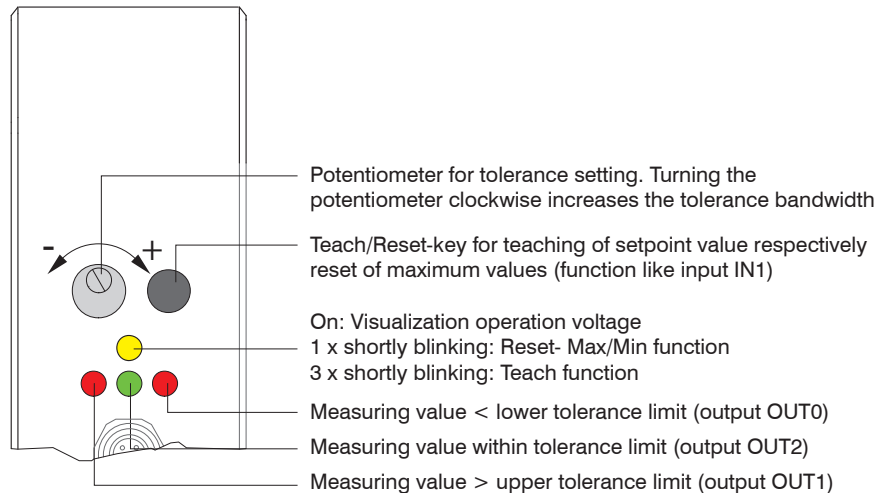

Fig. 10 Control and display elements at the receiver

There are no display elements located at the transmitter. The selection of mode, the video threshold et cetera is effected with the software tool exclusively.

6.2 Evaluation Mode

The optoCONTROL is delivered with the mode L-EDGE factory-made. You can change the mode only via the software tool.

L-EDGE:

The first detected edge in the intensity profile of the CCD line is evaluated.

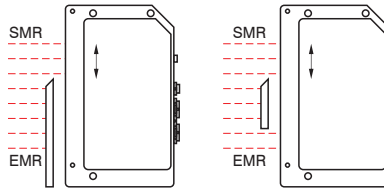

R-EDGE:

The second detected edge in the intensity profile of the CCD line is evaluated.

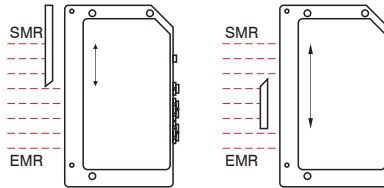

WIDTH:

The difference between the last edge and the first edge (for width and gap) in the intensity profile of the CCD is evaluated.

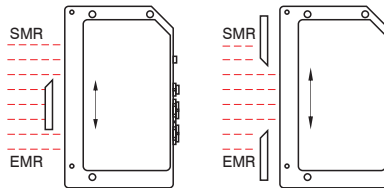

CENTER:

The mean value of the first and second edge is used as measurement value:

$$\text{CENTER} = (\text{R-EDGE} + \text{L-EDGE})/2$$

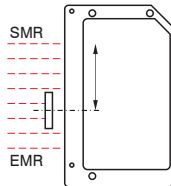

6.3 Analog Output

Characteristics: Voltage output

- 0 V ... 10 V, max. 3 mA
- Resolution: 12 bit DA-converter

Computation of a value:

$x \text{ [mm]} = \frac{U_{\text{OUT}} * \text{MR}}{10 \text{ V}}$	<p>Output signal $U_{\text{OUT}} = 100 \% \text{ Measuring signal};$ $\text{MR} = \text{Measuring range}$</p>	<p>Example: $U_{\text{OUT}} = 4.6 \text{ V}$ $\text{Measuring range} = 72 \text{ mm}$ $\text{Value} = 33.1 \text{ mm}$</p>
--	--	---

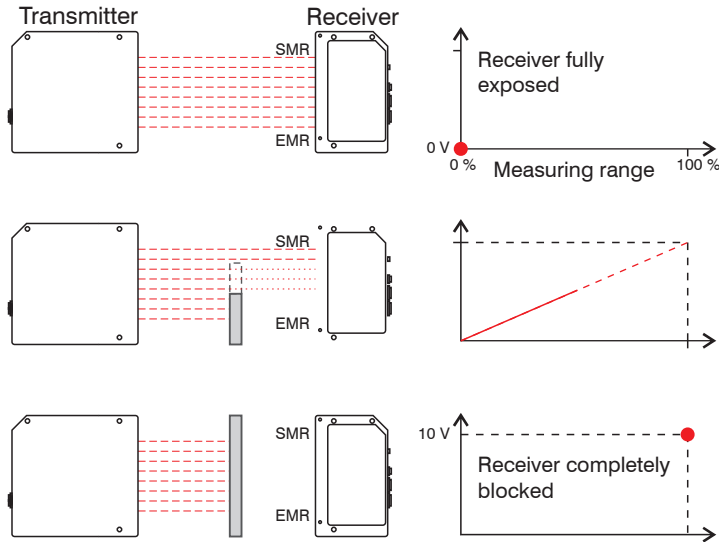

The system outputs 0 V, if no object blocks any light and the receiver is fully exposed.

As the light for the receiver increases the output voltage linearly.

If the light curtain is fully covered by a target the receiver outputs a signal of 10 V.

Fig. 11 Analog signal behaviour with different target positions

6.4 Limit Monitoring, Digital Outputs

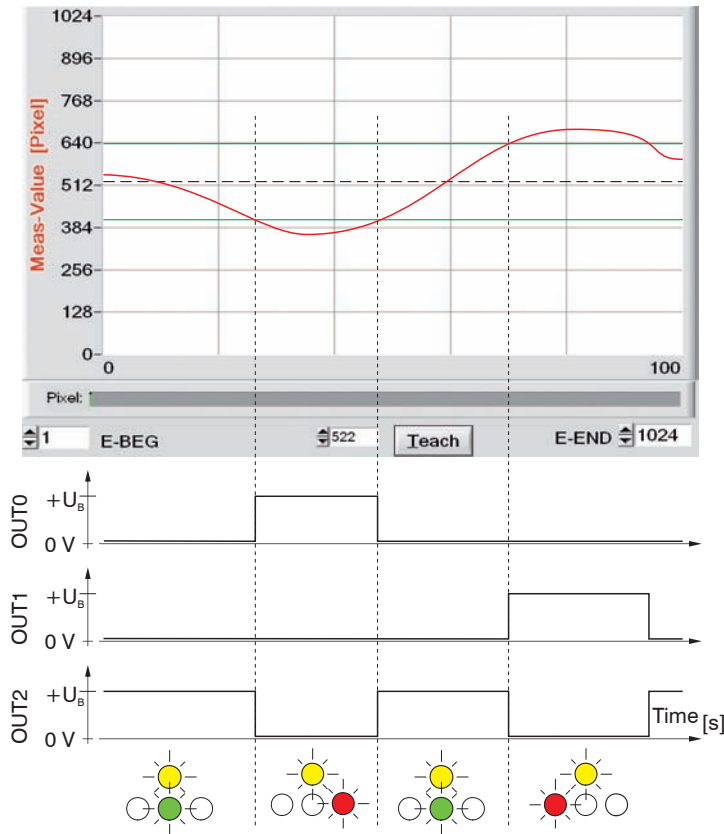

Fig. 12 Switching behaviour of the digital outputs, output polarity (POLARITY) = DIRECT

If the receiver detects a signal below the tolerance limit for example, the according digital output is set. Also LED's on the receiver indicate the states of the digital outputs.

There to a measuring window must be parameterized. The setup is effected

- at the receiver via the
 - "Teach"- key and the
 - tolerance potentiometer, see Chap. 6.1, in the software tool via the parameter
 - "Teach" and
 - "TOLERANCE-VALUE", see software description.

6.5 External Triggering, IN0

When a HIGH-pulse at digital input IN0 is applied the external triggering at the hardware is activated.

i The trigger mode is only possible in the both trigger modes „EXT. IN0 L/H“ and „EXT. IN0 HIGH“, see the software description.

Depending on the adjusted analog output mode the analog outputs and digital outputs are updated only, if the trigger requirement is performed.

The receiver electronics resets the MAX/MIN value on IN0 with the new LOW/HIGH edge. During the HIGH-pulse at IN0 (window) the MAX-MIN search to the drag indicator principle is active. The respectively actual MAX/MIN value is inside this window output at pin 8/red. If the HIGH-pulse is reset on IN0, the during the window detected MAX/MIN value persists on the analog output. First the next LOW/HIGH edge of the thereon following window resets the analog value.

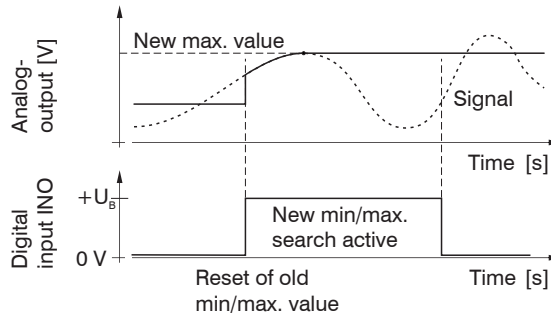

Within the MAX/MIN search the analog output can be reset

- by pressing the RESET key
- or a pulse at input IN1 ($t < 750$ ms).

Fig. 13 Function of external triggering

The example in Fig. 13 requires a TRIG-MODE „EXT. IN0 HIGH“ (Trigger Mode) and a ANA-OUT „MAXIMA“ (Analog Output Mode).

The trigger mode EXT IN0 L/H provides the actual measuring value with the rising edge at analog output.

6.6 RESET Function, IN1

When a HIGH-pulse of less than 750 ms duration is applied at input IN1, see Fig. 14, the RESET function is performed at the receiver. This resets the current maximum and minimum values. If the receiver detects a RESET pulse, the yellow LED at the housing of the receiver blinks shortly one time, see Fig. 15.

6.7 TEACH Function, IN1

When a HIGH-pulse of more than 1.5 s duration is applied at Input IN1, see Fig. 14, the TEACH function is performed at the receiver. If the receiver detects a TEACH pulse, the yellow LED at the housing of the receiver blinks shortly three times.

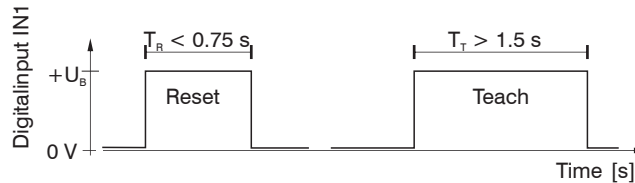

Fig. 14 Pulse duration at digital input IN1 decides about Reset- or Teach function



- On: Visualization operating voltage
- 1 x shortly blinking: Reset- max/min function
- 3 x shortly blinking: Teach function

Fig. 15 Yellow multifunction LED on the receiver

6.8 Software Tool

The ODC1202 tool software is used for parameterizing and controlling the optoCONTROL 1202.

The measured values provided by the receiver can be visualized with the PC software. The software provides you among other things

- at the adjustment of transmitter and receiver
- at setting of suitable tolerance limits.

The data exchange between the PC and the receiver is effected through a standard RS232 interface. For this purpose the receiver is connected to the PC with the serial interface cable SCD1202-x. When parameterization is finished, the setting values can be permanently saved in an EEPROM memory of the receiver. The optoCONTROL 1202 then continues operation in the "STAND-ALONE" mode without PC.

Functions of the software:

- Visualization of measurement data in numeric and graphic output fields
- Setting of the laser power for the laser transmitter
- Setting of the polarity of the digital switching outputs OUT0, OUT1, and OUT2
- Selection of a suitable evaluation mode
- Presetting of setpoint value and tolerance band
- Saving of parameters in a EEPROM memory at the receiver, or in a configuration file on the hard disk of the PC

i A detailed description of the software you will find as file on the provided CD-ROM.

Hardware requirements for the software:

- 100 MHz Pentium-compatible processor or better
- CD-ROM or DVD-ROM drive
- Approximately 8 MByte of free hard disk space
- SVGA graphics card with at least 800x600 pixel resolution and 256 colors or higher
- Windows 98, Windows NT4.0, Windows 2000, or Windows XP operating system
- Free serial RS232 interface or USB port with USB-RS/232 adaptor on PC

6.9 Sensor Mounting with Video Signal

Requirements:

- optoCONTROL completely mounted and wired, operating voltage fits, see Chap. 5.
- There is no target between transmitter and receiver.
- The software tool is installed.

After a click on the VIDEO button, the fine adjustment between the ODC transmitter unit and the receiver can be observed in the graphic display window. In the graphic display the intensity profile is shown as a red curve. The numerical values 1 ... 1024 on the x-axis represent the individual pixels of the CCD line. The analog values of the CCD line are converted by way of an AD converter and displayed in a y-axis value range of 0 .. 1023. Transmitter and receiver are optimally adjusted, if the receiver is uniformly illuminated, see Fig. 16.

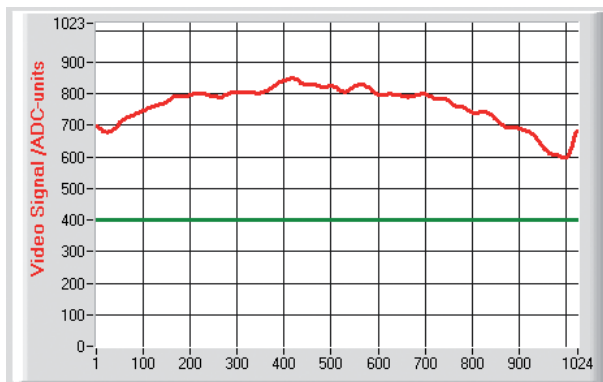

Fig. 16 Intensity distribution on receiver at optimal mounting of transmitter and receiver



A detailed description of the transmitter mounting with the support of the video signal you will find as file on the provided CD-ROM.

7. Calibration

A detailed description of the system calibration for the width-/ thickness measurement, mode "Width", you will find in the software description.

8. Warranty

All components of the device have been checked and tested for perfect function in the factory.

In the unlikely event that errors should occur despite our thorough quality control, this should be reported immediately to MICRO-EPSILON Eltrotec. The warranty period lasts 12 months following the day of shipment. Defective parts, except wear parts, will be repaired or replaced free of charge within this period if you return the device free of cost to MICRO-EPSILON Eltrotec.

This warranty does not apply to damage resulting from abuse of the equipment and devices, from forceful handling or installation of the devices or from repair or modifications performed by third parties. No other claims, except as warranted, are accepted. The terms of the purchasing contract apply in full.

MICRO-EPSILON Eltrotec will specifically not be responsible for eventual consequential damages. MICRO-EPSILON Eltrotec always strives to supply the customers with the finest and most advanced equipment. Development and refinement is therefore performed continuously and the right to design changes without prior notice is accordingly reserved.

For translations in other languages, the data and statements in the German language operation manual are to be taken as authoritative.

9. Service, Repair

In the event of a defect on the sender or on the receiver please send us the effected parts for repair or exchange.

In the case of faults the cause of which is not clearly identifiable, the whole measuring system must be sent back to:

MICRO-EPSILON Eltrotec GmbH
Heinkelstraße 2
D-73066 UHINGEN

Tel. 07161/98872-300
Fax 07161/98872-303
eltrotec@micro-epsilon.de
www.micro-epsilon.de

10. Decommissioning, Disposal

➡ Disconnect at receiver

- the power supply- and output cable (SCA1202-4),
- the interface cable (SCD1202-x).

The optoCONTROL 1202 is produced according to the directive 2011/65/EU („RoHS“).The disposal is done according to the legal regulations (see directive 2002/96/EC).

11. Optional Accessories

PS2020 Power supply unit (Mounting on DIN-rail), output 24 VDC, input 240 VAC, switchable for 110 VAC

CE1202-x Connection cable transmitter/receiver

12. Factory Setting

Mode: L-Edge

Average number: 2 values



MICRO-EPSILON Eltrotec GmbH
Heinkelstraße 2 · 73066 Uhingen / Germany
Tel. +49 (0) 7161 / 98872-300 · Fax +49 (0) 7161 / 98872-303
eltrotec@micro-epsilon.de · www.micro-epsilon.com

X9751200-A041113HDR
© MICRO-EPSILON MESSTECHNIK

