



Instruction Manual
colorCONTROL S Software

Version V4.2

colorSENSOR

LT-1-LC-20

LT-3-HE

LT-3-LU

OT-3-MA (30/50/80)

OT-3-GL (30/50/80)

OT-3-HR (30/50/80)

OT-3-LD

OT-3-LU

PC software for Microsoft® Windows® 7, Vista, XP, Me, 2000

MICRO-EPSILON
Eltrotec GmbH
Heinkelstraße 2

73066 Uhingen / Germany

Tel. +49 (0) 7161/ 98872-300
Fax +49 (0) 7161/ 98872-303
e-mail: eltrotec@micro-epsilon.de
www.micro-epsilon.com



Certified according to DIN EN ISO 9001: 2008

Software revision

V4.2

Contents

1.	Safety	5
2.	Introduction	5
3.	Installing colorCONTROL S Software	6
4.	Operation of the colorCONTROL S Software	7
4.1	Tabs and Basic Functions – Overview	7
4.2	CONNECT Tab	8
4.3	Basic Functions	10
4.3.1	SEND Button	10
4.3.2	GET Button	10
4.3.3	GO Button	10
4.3.4	STOP Button	10
4.3.5	RAM	10
4.3.6	EE (EEProm)	10
4.3.7	FILE	10
4.3.8	SET	11
4.4	PARA1 Tab	12
4.4.1	POWER MODE	12
4.4.1.1	STATIC	12
4.4.1.2	DYNAMIC	12
4.4.2	LED MODE	13
4.4.2.1	DC	13
4.4.2.2	AC	13
4.4.2.3	PULSE	13
4.4.2.4	OFF	13
4.4.3	GAIN	13
4.4.4	AVERAGE	13
4.4.5	INTEGRAL	13
4.4.6	MAXCOL-No	14
4.4.7	OUTMODE	14
4.4.7.1	BINARY	14
4.4.7.2	DIRECT	14
4.4.8	INTLIM	15
4.4.9	EVALUATION MODE	15
4.4.9.1	FIRST HIT	16
4.4.9.2	BEST HIT	17
4.4.9.3	MIN DIST	18
4.4.9.4	COL5	19
4.4.9.5	THD RGB	20
4.4.10	CALCULATION MODE	21
4.4.10.1	X Y INT - 2D	21
4.4.10.2	s i M - 2D	21
4.4.10.3	X Y INT - 3D	21
4.4.10.4	s i M - 3D	21
4.4.11	TRIGGER	23
4.4.11.1	CONT	23
4.4.11.2	SELF	24
4.4.11.3	EXT1	24
4.4.11.4	EXT2	24
4.4.11.5	EXT3	24
4.4.11.6	TRANS	24
4.4.11.7	PARA	25
4.4.12	EXTEACH	25
4.4.12.1	OFF	25
4.4.12.2	STAT1	25
4.4.12.3	DYN1	25
4.4.12.4	ON	26
4.5	PARA2 Tab	28
4.5.1	COLOR GROUPS	28
4.5.2	SELECT HOLD [ms] FOR EACH ROW - HOLD	29
4.6	TEACH Tab	30
4.6.1	X Y INT/ s i M	31
4.6.1.1	X or s	31
4.6.1.2	Y or i	31
4.6.1.3	INT or M	31
4.6.2	C-No.	31
4.7	GEN Tab	35
4.8	REC Tab	36
4.9	CALIB Tab	39
4.9.1	White Light Balancing	39
4.9.2	Offset Calibration	42
4.10	SCOPE Tab	44
4.11	Graphic Display Elements	46
4.11.1	Delta C	47

Appendix



A 1	Quick Reference Guide for the Operation of Color Sensors	48
A 2	Using TEMPCOMP-Scope Software	52
A 3	External Triggering of colorSENSOR LT or OT	53
A 4	LED Displays at the Color Sensors	54
A 4.1	Operating Modes	54
A 4.1.1	BINARY	54
A 4.1.2	DIRECT HI	55
A 4.1.3	DIRECT LO	55
A 5	Color Sensor Pin Assignments	56
A 5.1	Connecting colorSENSOR LT or colorSENSOR OT to a PC	56
A 5.2	Connecting colorSENSOR LT or OT to a PLC	56
A 6	RS232 Communication Protocol	57
A 6.1	Parameters	57
A 6.2	TEACH VECTOR	58
A 6.3	DATA VALUE	59
A 6.4	Examples	63
A 6.4.1	Write Parameters to the Sensor RAM	63
A 6.4.2	Read Parameters from the Sensor RAM	64
A 6.4.3	Load Parameters and Current Baud Rate from the Sensor RAM to its EEPROM	65
A 6.4.4	Load Parameters from the Sensor EEPROM to its RAM	65
A 6.4.5	Read Connection OK from the Sensor	65
A 6.4.6	Read Firmware Sequence from the Sensor	66
A 6.4.7	Read Data Values from the Sensor	67
A 6.4.8	Start and Stop Triggered Sending of Data Frame Values from the Sensor	67
A 6.4.9	Start White Light Correction and Obtain Calibration Factors, Set Value and Max Delta of Raw Data	68
A 6.4.10	Obtain Cycle Time from the Sensor	68
A 6.4.11	Send New Baud Rate to the Sensor	69

1. Safety

The handling of the system assumes knowledge of the instruction manual.

1.1 Symbols

The following symbols are used in the instruction manual:

	Indicates a user action.
	Indicates a user tip.
Measurement	Indicates a hardware or a button/menu in the software.

2. Introduction

This instruction manual describes the installation of the PC software for colorSENSOR LT and colorSENSOR OT. As a support for commissioning the color sensors, this manual explains the individual functional elements of the Windows® graphical user interface.

colorSENSOR LT and colorSENSOR OT provide highly flexible signal acquisition. For example, the sensor can be operated in alternating-light mode (AC mode), which makes the sensor insensitive to extraneous light. It can also be set to constant-light mode (DC mode), which makes the sensor extremely fast and allows a scan frequency of over 30 kHz. An OFF function turns off the integrated light source at the sensor and switches to DC operation. The sensor can then detect so-called self-luminous objects. In PULSE operation extremely dark surfaces can be reliably detected. With the variable adjustment of the integrated light source, the selectable gain of the receiver signal and the INTE-GRAL feature, the sensor can be set to almost any surface or self-luminous object.

When the integrated light source of the colorSENSOR LT / colorSENSOR OT is activated, the sensor detects the radiation that is diffusely reflected from the measurement object. As a light source the colorSENSOR LT / colorSENSOR OT uses a white light LED with adjustable transmitter power. The receiver is an integrated triple receiver for the red, green and blue content of the light reflected from the measurement object or the light emitted from the self-luminous object. As described above, a special feature is that gain of the receiver can be set in 8 steps, making it possible to optimally adjust the sensor to almost any surface and different self-luminous objects.

colorSENSOR LT and colorSENSOR OT can be taught up to 31 colors. Each taught color can be assigned a tolerance. In X Y INT - 2D or s i M - 2D mode, these tolerance values form a color cylinder in space. In X Y INT - 3D or s i M - 3D mode, these tolerances form a color sphere in space. Color evaluation for s i M is based on the Lab method of calculation. All modes can be used in combination with several operating modes, including FIRST HIT and BEST HIT. Raw data is displayed with 12 bit resolution.

As special feature, the sensor can be taught two completely independent sets of parameters, and the IN0 input communicates to the sensor which parameter set to use.

Color detection either operates continuously or is started through an external PLC trigger signal. A detected color either is provided as binary code at the 5 digital outputs or it is sent directly to the outputs for detection of no more than 5 colors. Simultaneously, the detected color code is visualized using 5 LEDs at the colorSENSOR LT / colorSENSOR OT housing.

A TEACH button at the sensor housing is used to teach up to 31 colors to the color sensor, which requires specifying the corresponding evaluation mode with the software. The TEACH button operates in parallel to the IN0 input (green wire at cable CAB-M9-8P-St-ge; Xm-PUR; open).

Parameters and measured values are exchanged between PC and colorSENSOR LT / colorSENSOR OT through the RS232 interface. All parameters for color detection can be saved to the non-volatile EE (EEPROM) for colorSENSOR LT / colorSENSOR OT through the serial RS232 interface. After configuration is completed, the color sensor continues to operate with the current parameters in STAND-ALONE mode without a PC.

As a light source the colorSENSOR OT-3-LU-... color sensors use a UV-LED (385 nm) with adjustable transmitter power to excite the luminescent marking. These UV sensors can be optimally adjusted to almost any luminescent colorant that can be excited in the long-wave UV range (365 nm or 385 nm). The sensors in the colorSENSOR OT-3-LU-... series also can be calibrated. Analogous to white light balancing with color sensors, balancing of the colorSENSOR OT-3-LU-... could be performed to any luminescent color marking.

3. Installing colorCONTROL S Software

Hardware requirements for successful installation of the colorCONTROL S software:

- 1 IBM PC AT or compatible
- VGA graphics
- Microsoft® Windows® 7, Vista, XP, Me, 2000
- Serial RS232 interface at the PC
- Microsoft®-compatible mouse
- Cable for the RS232 interface (CAB-M5-4P-St-ge; Xm-PUR; RS232 or CAB-M5-4P-St-ge; Xm-PVC; USB)
- CD-ROM drive
- 20 MB free hard disk space

The colorCONTROL S software can only be installed under Windows operating systems.

➡ Please start Windows (if not yet running).

➡ Install the software as described below:

1. You can install the software directly from the installation CD-ROM. The CD-ROM contains the SOFTWARE folder with a SETUP application. To install the software, you need to start the SETUP application.

2. The installation program displays a dialog box and suggests to install the software to the C:\“FILENAME” directory on your hard disk.

➡ Click **OK** or press **ENTER** to accept this setting, or change the path as desired.

3. During installation, a new program group for the software is created in the Windows Program Manager. The setup program automatically creates an icon for starting the software within the program group. When installation is successfully completed, the setup program displays the **Setup OK** message.

4. After successful installation, you can start the software by double-clicking the icon with your left mouse button.

Windows® is a registered trademark of Microsoft Corp. VGA™ is a trademark of International Business Machines Corp.

4. Operation of the colorCONTROL S Software

Please read this section first before making adjustments and configurations for colorSENSOR LT or colorSENSOR OT.

When the colorCONTROL S software is launched, the following dialog appears on the Windows interface:

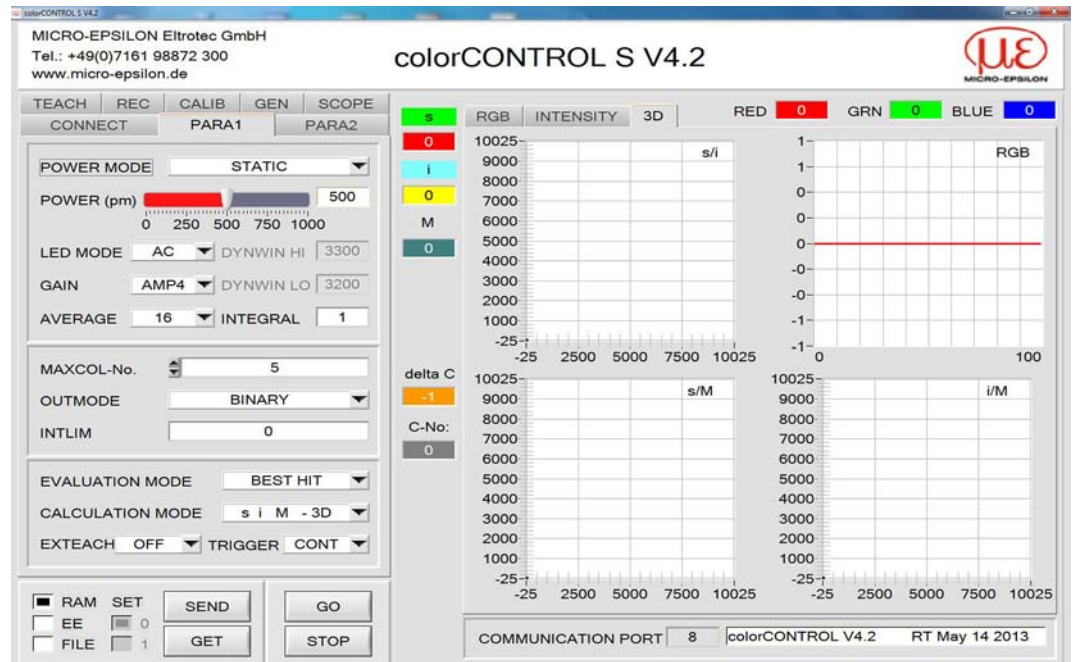

Fig. 1 colorCONTROL S software start screen

Size and position of the window are remembered from the last session. Double-click with the right mouse button, for example below the Minimize icon, to display the window in its original size in the center of the screen.

Clicking with the right mouse button on an individual item will display a context help.

4.1 Tabs and Basic Functions – Overview

The main menu of the colorCONTROL S software includes the following tabs:

CONNECT tab, see Chap. 4.2

PARA 1 tab, see Chap. 4.4

PARA 2 tab, see Chap. 4.5

TEACH tab, see Chap. 4.6

GEN tab, see Chap. 4.7

REC tab, see Chap. 4.8

CALIB tab, see Chap. 4.9

SCOPE tab, see Chap. 4.10

Underneath each tab you will find 4 buttons:

- SEND, see Chap. 4.3.1,
- GET, see Chap. 4.3.2,
- GO, see Chap. 4.3.3,
- STOP, see Chap. 4.3.4

and checkboxes for

- RAM, see Chap. 4.3.5.
- EE (EEProm), see Chap. 4.3.6,
- FILE, see chapter 4.3.7

4.2 CONNECT Tab

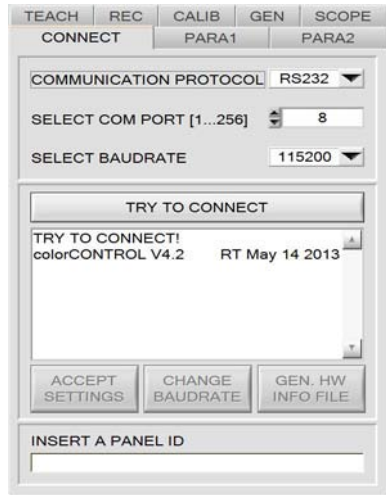

Fig. 2 CONNECT tab

➡ Select the **CONNECT** tab.

This displays a window in which you can select and configure the interface, see Fig. 2.

Use the **COMMUNICATION PROTOCOL** function field to select RS232 or a TCP/IP protocol, see Fig. 3.

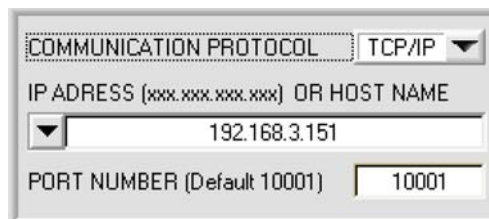

Fig. 3 CONNECT tab – COMMUNICATION PROTOCOL

If RS232 is selected, a port between 1 and 256 can be selected with **SELECT COM PORT**, see Fig. 2, depending on which port the sensor is connected to.

The sensor operates with a preset baud rate which can be modified through **CHANGE BAUDRATE**, see Fig. 2. The sensor and the user interface must use the same baud rate.

On the user interface, the baud rate is selected with **SELECT BAUDRATE**, see Fig. 2. If the software does not automatically establish a connection after it was started, you can use **SELECT BAUDRATE** to find the correct baud rate.

If an adapter is used, you can determine the **COM PORT** number through the hardware manager in the control panel.

An RS232/Ethernet adapter (CAB-M5-4P-St-ge; Xm-PVC; RJ45-Bu-Eth) is required to let the sensor communicate through a local network. The adapter establishes a connection to the sensor via the TCP/IP protocol.

The network adapters available from MICRO-EPSILON Eltrotec are based on the Lantronix XPort module. To configure the adapters (assigning an IP address, specifying the baud rate, etc.), you can download the “DeviceInstaller” software provided by Lantronix free of charge under <http://www.lantronix.com/>. DeviceInstaller is based on Microsoft's .NET Framework. You can obtain detailed instructions on using DeviceInstaller from Lantronix.

In order to establish a connection to the adapter, you must enter its IP address or host name into the **IP ADDRESS (xxx.xxx.xxx.xxx) OR HOST NAME** field, see Fig. 3. The dropdown menu displays the 10 last used IP addresses. An address from this list can be directly selected by clicking on the respective item. The dropdown list is saved when you exit the software.

The **PORT NUMBER** for the XPort-based network adapter is set to 10001 and must not be changed.

➔ Click the TRY TO CONNECT button, see Fig. 4

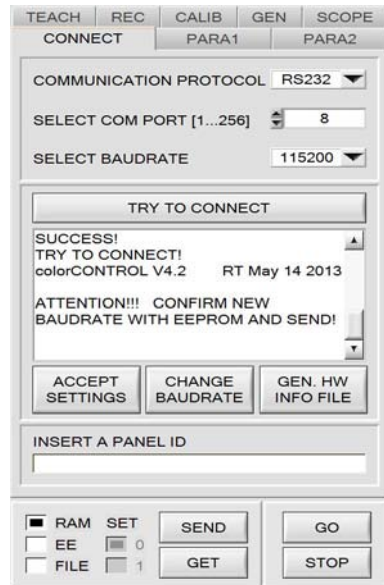

Fig. 4 CONNECT tab

The software attempts to establish a connection with the specified parameters. The display field shows the communication status. If the sensor answers with its firmware ID, you can accept the specified connection type by clicking ACCEPT SETTINGS, see Fig. 4. You will then automatically be returned to the PARA1 tab. If you receive an error message, the software was unable connect to the sensor.

➔ In this case, please check if the interface cable is correctly connected, if the sensor is supplied with power and if the specified parameters are correct.

Once you confirm a connection by clicking ACCEPT SETTINGS, the software starts automatically with this setting when launched the next time.

• Stable interface function is a prerequisite for measurement values transfer from the PC to the sensor.

Due to the limited data transfer rate via the serial RS232 interface, only slow changes of the raw signal at the sensor can be observed in the graphic output window of the PC.

You must terminate the data exchange with the PC in order to maintain the sensor's maximum switching frequency.

➔ To do this, click the STOP button.

You can use SELECT BAUDRATE and CHANGE BAUDRATE to adjust the baud rate for data transfer through the RS232 interface.

➔ Establish a connection using TRY TO CONNECT.

This will activate the CHANGE BAUDRATE button.

➔ Now click SELECT BAUDRATE to select a new baud rate.

➔ Click CHANGE BAUDRATE.

This sends the new baud rate to the sensor.

When the new baud rate has been transmitted successfully, the sensor operates with the new baud rate. A popup window is displayed, prompting you to select EE (EEPROM).

➔ Select EE (EEPROM) and click SEND, see Fig. 5



Fig. 5 Popup window showing that EE (EEPROM) is selected

Now the new baud rate is used after a hardware reset.

➔ Click ACCEPT SETTINGS.

The current interface settings are saved and take effect automatically after the software is restarted.

Use the button GEN. HW INFO FILE, see Fig. 4, to create a file which stores and encrypts all important sensor data.

This file can be sent to MICRO-EPSILON Eltrotec for diagnostic purposes.

4.3 Basic Functions

The following 4 buttons are displayed at the bottom of each tab: SEND, GET, GO and STOP.



Fig. 6 Basic function buttons

Since this is a PC-based software, any changes must first be transferred to the sensor or fed back by sending the appropriate command using the SEND and GET buttons. Click GO or STOP to activate or end the sensor's run mode.

4.3.1 SEND Button

Click SEND or press shortcut key F9 to transfer all currently specified parameters between PC and sensor. The target of the respective parameter transfer is determined by selecting RAM, EE (EEProm) or FILE, see Fig. 5.

4.3.2 GET Button

Click GET or press shortcut key F10 to retrieve the current settings from the sensor. The source of the data exchange is specified by selecting RAM, EE (EEProm) or FILE, see Fig. 5.

4.3.3 GO Button

Click GO or press shortcut key F11 to initiate the data transfer from the sensor to the PC through the serial interface. You can display the corresponding graph by selecting the relevant tab on the right-hand tab panel, see Fig. 1.

4.3.4 STOP Button

Click STOP or press F12 to end the data transfer from the sensor to the PC through the serial interface.

4.3.5 RAM

After clicking SEND, the current parameters are transferred to the RAM memory of the sensor, and when you click GET the parameters are retrieved from the sensor's RAM, i.e. these parameters are lost when the voltage at the sensor is switched off.

4.3.6 EE (EEProm)

After clicking SEND, the current parameters are transferred to the sensor's non-volatile EE (EEProm), and when you click GET, they are retrieved from the EE (EEProm), i.e. any parameters stored in the internal EE (EEProm) memory are preserved when the voltage at the sensor is switched off.

4.3.7 FILE

After clicking SEND, the current parameters can be written to an optional file on the hard drive, and when you click GET they are read from this file. Clicking SEND or GET opens a dialog box in which you can select the desired file.

4.3.8 SET

i SET is only active when TRIGGER = PARA.

If you use TRIGGER = PARA, see Fig. 7, then two sets of parameters can be stored in the sensor.

SET is used to select if the current parameters should be stored on the sensor's user interface as parameter set 0 or parameter set 1.

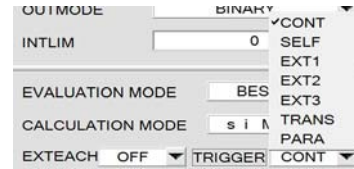

Fig. 7 TRIGGER options

In online mode, input IN0 is used to select with which parameter the test is carried out.

IN0 Low = Set0

IN0 High = Set1

4.4 PARA1 Tab

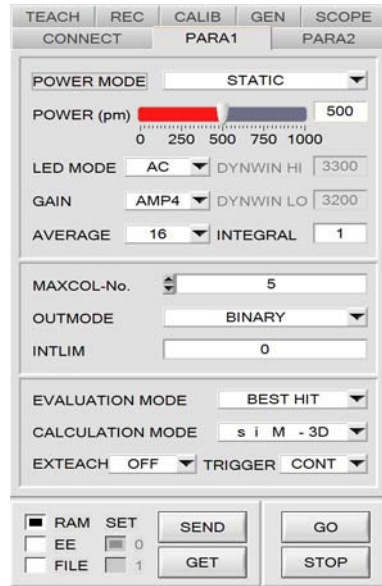

Fig. 8 PARA 1 tab

➡ Select the `PARA1` tab.

A window opens in which you can adjust the sensor parameters.

! Any changes made in the software must be transferred to the sensor by clicking `SEND` in order to apply them to `colorSENSOR LT` or `colorSENSOR OT`.

4.4.1 POWER MODE

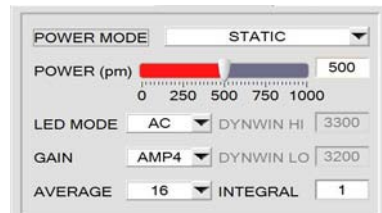

Fig. 9 PARA1 tab – POWER MODE = STATIC

Use this function field to specify the mode of automatic power correction at the transmitter unit.

4.4.1.1 STATIC

Transmitter power is constantly kept at the value set with the `POWER [pm]` slider (recommended mode). `POWER` can be adjusted using the slider or by entering a value in the edit box. A value of 1000 means full intensity at the transmitter, a value of 0 stands for the lowest intensity at the transmitter. For an example, see [Fig. 30](#).

4.4.1.2 DYNAMIC

LED transmitter power is dynamically controlled in accordance with the amount of radiation that is diffusely reflected from the object.

By using the intensities measured at the receivers, the automatic control circuit attempts to adjust the transmitter power in such a way that the dynamic range specified with `DYN WIN LO` and `DYN WIN HI` is not exceeded.

If `POWER MODE = DYNAMIC`, the intensity is measured using the `POWER` value instead of the intensity calculated from the signals. In other words, the transmitter intensity is evaluated which corresponds to the `POWER` parameter. The reason for this is that the `DYN WIN LO` and `HI` values basically instruct the sensor which intensity to use. The power going to the transmitter in order to achieve this intensity is much more meaningful than the intensity of the signal itself and it is displayed under `INT` or `M` to the left of the graph.

! The `POWER` slider is only active if `POWER MODE = STATIC`.
! `DYN WIN LO` and `DYN WIN HI` are only active if `POWER MODE = DYNAMIC`.

4.4.2 LED MODE

This function field sets the control mode for the sensor's integrated light source.

4.4.2.1 DC

In this mode the sensor operates extremely fast and reaches a scan frequency of over 30 kHz. The sensor is, however, somewhat sensitive to extraneous light in DC mode, but if the external light source does not directly shine into the sensor's receiver, the signal is only influenced to a very small extent.

4.4.2.2 AC

In this mode the sensor is insensitive to extraneous light, which is achieved by modulating the integrated light source, i.e. switching the light on and off. The extraneous content in the signal is determined in off status and is simply subtracted from the on status.

4.4.2.3 PULSE

In pulse mode the transmitter unit is pulsed, which for a very short time directs a high light intensity onto the object. Afterwards the transmitter unit must be turned off for a longer time, which compared to the AC mode reduces the scan frequency approximately by a factor of 5.

4.4.2.4 OFF

The sensor's internal light source is turned off, and the sensor can now be used for self-luminous objects. These are light sources that actively emit light (LEDs, lamps, etc.). In OFF mode, neither POWER MODE nor POWER can be adjusted, and external teaching with DYN1 is not possible.

4.4.3 GAIN

This field is used to set the gain of the receiver, and you can choose from 8 different gain levels: AMP1 to AMP8. GAIN should be set in such a way that with a medium Power value the sensor operates in its dynamic range (red, green, blue between 2750 and 3750).

In AC and PULSE mode, GAIN directly influences the scan frequency. You can retrieve the current scan frequency for your sensor settings from the SCOPE tab, see Chap. 4.10.

4.4.4 AVERAGE

This function field is used for adjusting the number of scanning values (measurement values) over which the raw signal measured at the receiver is averaged. A higher AVERAGE default value reduces noise of the raw signals at the receiver unit and there will be a decrease of the maximum available switching frequency of the sensor.

4.4.5 INTEGRAL

This function field is used for adjusting the number of scanning values (measurement values) over which the raw signal measured at the receiver is added up. This integral function allows the reliable detection even of extremely weak signals. A higher INTEGRAL default value increases the noise of the raw signals for the receiver unit, and simultaneously decreases the maximum achievable switching frequency of the sensor.

4.4.6 MAXCOL-No



Fig. 10 PARA1 tab – MAXCOL-No.

This function field specifies the number of colors to be checked. In **BINARY** mode, a maximum of 31 colors can be checked, see Chap. 4.4.7.1, and in **DIRECT HI** or **DIRECT LO** mode the maximum number is 5 (0, 1, 2, 3, 4).

The numerical value set here determines the currently possible scanning rate for the colorSENSOR LT or colorSENSOR OT. The less colors to be checked, the faster the sensor operates. The numerical value set here refers to the number of rows (starting with row 0) in the **TEACH** color table, see Chap. 4.6.

4.4.7 OUTMODE



Fig. 11 PARA1 tab – OUTMODE

Use this dropdown menu to select the method for controlling the 5 digital outputs.

4.4.7.1 BINARY

If in this row-by-row comparison the current color values correspond with the teach-in parameters entered in the color table, the match in the color table is displayed as a color number (C-No.) and sent to the digital outputs (OUT0 ... OUT4) as a bit pattern.

Example:

Color to memory 3 = OUT0 and OUT1; color to memory 4 = OUT2

A maximum of 31 colors can be output.

4.4.7.2 DIRECT

The maximum number of teach-in colors in this mode is 5.

If in this row-by-row comparison the current color values correspond with the teach-in parameters entered in the color table, the match in the color table is displayed as a color number (C-No.) and is output directly at the digital outputs (OUT0 ... OUT4).

Example:

Color to memory 1 = OUT1; color to memory 3 = OUT3

- DIRECT HI

If **OUTMODE = DIRECT HI**, the corresponding digital output is set to HI. If no color is detected, the digital outputs are set to LO (no LED is lit).

- DIRECT LO

If **OUTMODE = DIRECT LO**, the corresponding digital output is set to LO and the others are set to HI. If no color is detected, the digital outputs are set to HI (all LEDs are lit).

4.4.8 INTLIM



Fig. 12 PARA1 tab – INTLIM

This input field specifies the intensity limit. If the current intensity `INT` arriving at the receiver unit falls below this limit, color evaluation is stopped and an error state is triggered.

i Error state if: `INT < INTLIM`

If `POWER MODE = DYNAMIC`, intensity evaluation is based on the `POWER` value instead of the intensity calculated from the signals (`POWER MODE = DYNAMIC`). This means that the `INT` or `M` display no longer shows the actual intensity. Instead it displays the transmitter's intensity which corresponds to the `POWER` parameter. The sensor, however, continues to calculate the actual intensity and uses it to query `INTLIM`.

4.4.9 EVALUATION MODE

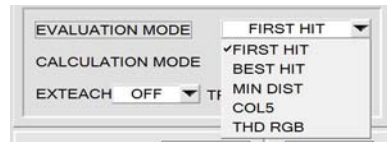

Fig. 13 PARA1 tab – EVALUATION MODE

The `EVALUATION MODE` function field specifies the evaluation mode for `colorSENSOR LT` or `colorSENSOR OT`.

- The `CALCULATION MODE` function field is active in the evaluation modes `FIRST HIT`, `BEST HIT`, `MIN DIST`, see Fig. 20 and for `COL5`.
The raw data for red, green and blue are used to calculate color information which is then evaluated.
- The `THD RGB` evaluation mode simply assigns switching thresholds for the corresponding channels.
It uses the individual raw data for red, green and blue for evaluation.
If the current signal is higher than the specified threshold, the corresponding output is set to HI.
If the signal is lower, the output is set to LO.

The `TEACH` table is correspondingly adapted, depending on `EVALUATION MODE` and `CALCULATION MODE`.

The explanation of the evaluation modes `FIRST HIT`, `BEST HIT`, `MIN DIST` and `COL5` is based on `CALCULATION MODE X Y INT - 2D`.

4.4.9.1 FIRST HIT

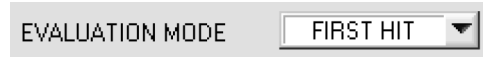

Fig. 14 PARA1 tab – EVALUATION MODE – FIRST HIT

	X	Y	INT	ITO	
0	2376	892	40	1570	200
1	1373	1710	40	1095	200
2	1126	1078	40	1130	200
3	1	1	1	1	1

Fig. 15 PARA1 tab – FIRST HIT – TEACH table

The currently measured color values are compared to the default values in the TEACH table (color table), see Fig. 15, starting with teach-in color 0. If in this row-by-row comparison the current color values correspond with the teach-in parameters entered in the color table, the first match in the color table is displayed as a color number (C-No.) and is output at the digital outputs (OUT0 ... OUT4) in accordance with the settings of the OUTMODE parameter (see OUTMODE).

If the current color does not correspond with any of the teach-in colors, color code C-No. = 255 will be set (error state).

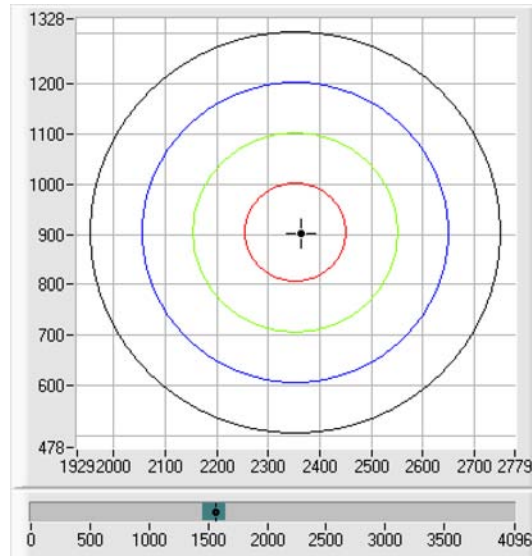

Fig. 16 PARA1 tab – FIRST HIT – Display graph

Tip:

- This mode is used when teaching a single color only and this color needs to be checked for drifting. This can be detected easily thanks to the rising tolerance windows, and countermeasures can be initiated, if required.
- If, for example, only X/Y coordinates should be checked and intensity INT is of no importance, you can select an ITO tolerance of 4000, ensuring that this inspection criterion is fulfilled at all times.
- You can enter values into a cell in the table either by double-clicking the respective cell or by selecting the cell and pressing F2.
The teach-in colors are only activated when you click SEND.

4.4.9.2 BEST HIT



Fig. 17 PARA1 tab – EVALUATION MODE – BEST HIT

	X	Y	CTD	INT	ITO	
0	2364	894	200	1580	200	Red
1	1379	1700	200	1112	200	Green
2	1120	1084	200	1127	200	Blue
3	1	1	1	1	1	Black

Fig. 18 PARA1 tab – BEST HIT – TEACH table

The currently measured color values are compared to the default values in the TEACH table (color table), starting with teach-in color 0. If in the row-by-row comparison the current color values correspond with several of the teach parameters entered in the color table, the teach parameter that has the shortest x/y distance from the current color value will be a hit.

This hit in the color table is displayed as a color number (C-No.) and is output at the digital outputs (OUT0 ... OUT4) in accordance with the settings of the OUTMODE parameter, see Chap. 4.4.7 (OUTMODE).

If the current color does not correspond with any of the teach-in colors, color code C-No. = 255 will be set (error state).

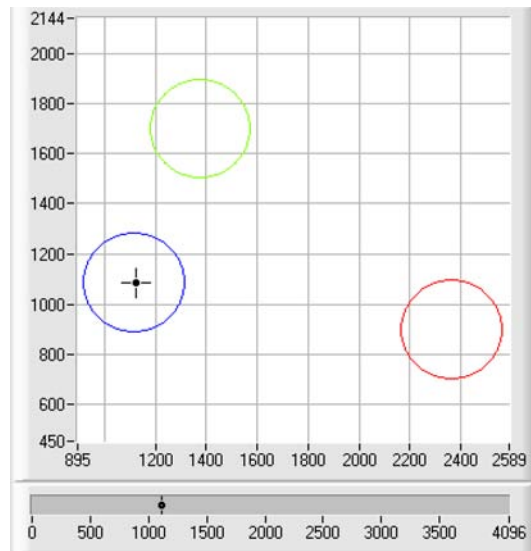

Fig. 19 PARA1 tab – BEST HIT – Display graph

The currently measured color values are compared to the default values in the TEACH table (color table), starting with teach-in color 0. If in the row-by-row comparison the current color values correspond with several of the teach parameters entered in the color table, the teach parameter that has the shortest x/y distance from the current color value will be a hit.

This hit in the color table is displayed as a color number (C-No.) and is output at the digital outputs (OUT0 ... OUT4) in accordance with the settings of the OUTMODE parameter, see Chap. 4.4.7 (OUTMODE).

If the current color does not correspond with any of the teach-in colors, color code C-No. = 255 will be set (error state).

Tip:

- This mode is used if several colors must be separated from each other and only certain surface fluctuations are allowed.
- Since what you are looking for when getting several hits is the shortest distance of the current color to the centers of the taught colors, the individual tolerance windows (circles) may overlap. The sensor detects the best result.
- You can enter values into a cell in the table either by double-clicking the respective cell or by selecting the cell and pressing F2.
- In CALCULATION MODE X Y INT - 3D or s i M - 3D the shortest distance in a three-dimensional space is calculated.
- The teach-in colors are only activated when you click SEND.

4.4.9.3 MIN DIST

The individual teach-in colors defined in the color table exist as points in the color triangle based on their (X,Y) value pairs. When this evaluation mode is set at the sensor, the evaluation algorithm, starting from the currently measured color value (X,Y), calculates the distance to the individual teach-in colors in the color triangle. The current color value (X,Y) is assigned to the teach-in color that is closest in the color triangle.

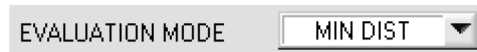

Fig. 20 PARA1 tab – EVALUATION MODE – MIN DIST

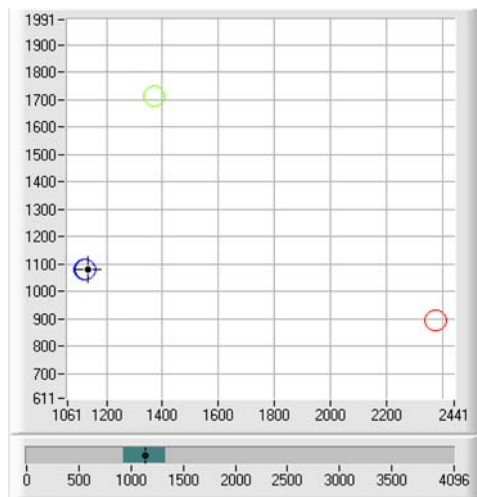

Fig. 21 PARA1 tab – MIN DIST – Display graph

In addition, the system checks whether the intensity condition for this color is true. If the intensity condition is not true, the second shortest distance will be checked, etc.

The determined color is output at the digital outputs (OUT0 ... OUT4) in accordance with the settings of the OUTMODE parameter, see Chap. 4.4.7 (OUTMODE).

C-No. will only be set to 255, if the current intensity falls below the value set under INTLIM, see Chap. 4.4.8 (INTLIM).

i The value of 40, see Fig. 22, is only entered here in order to be able to represent the coordinates of the individual teach-in colors in the graph. It is of no importance for the evaluation.

	X	Y	INT	ITO		
0	2376	892	40	1570	200	Red
1	1373	1710	40	1095	200	Green
2	1126	1078	40	1130	200	Blue
3	1	1	1	1	1	Black

Fig. 22 PARA1 tab – Color table (TEACH)

Tip:

- This mode is used after teaching several surfaces of separate colors and if a current color must be assigned to one of the taught colors. This applies, for example, if you want to compensate for product variation or in sorting tasks.
- If, for example, only X/Y coordinates need to be checked and intensity INT is of no importance, you can select an ITO tolerance of 4000, ensuring that this inspection criterion is always fulfilled.
- You can enter values into a cell in the table either by double-clicking the respective cell or by selecting the cell and pressing F2.
- In CALCULATION MODE X Y INT - 3D or s i M - 3D the shortest distance in a three-dimensional space is calculated.
- The teach-in vectors are only activated when you click SEND.

4.4.9.4 COL5

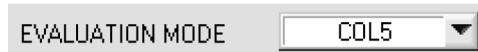

Fig. 23 PARA1 tab – EVALUATION MODE – COL5

This evaluation mode evaluates rows 0 to 4 in the TEACH table, see Fig. 24.

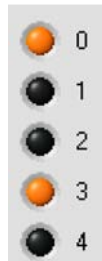

Fig. 24 Rows 0 to 4 in the TEACH table

Every match of current color (row number) and teach vector is sent directly to the corresponding output.

Example:

If the result of the evaluation is that both row 0 and row 3 are hits, outputs OUT0 and OUT3 will be set to high (+24 V).

Please also note:

- If the result of evaluation is that both row 0 and row 3 is a hit, outputs OUT0 and OUT3 will be set to high (+24 V).
- You can enter values into a cell in the table either by double-clicking the respective cell, or by selecting the cell and pressing F2.
- The teach-in vectors are only activated when you click SEND.
- Color groups cannot be formed in COL5 evaluation mode.

4.4.9.5 THD RGB

Individual switching thresholds can be set for red, green and blue in this evaluation mode.

If the corresponding channel is above the threshold, then OUT0 is HI. Otherwise it is LO.

HOLD is used to lengthen the output pulse for error state 255.

If one of the three outputs changes its state, the time set for HOLD will start.

LEDs 0,1 and 2 are used for surface visualization.

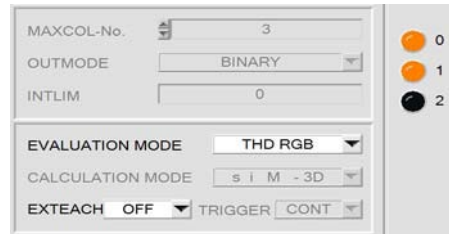

Fig. 25 PARA1 tab – EVALUATION MODE – THD RGB – EXTEACH OFF

The switching threshold for red is specified in the TEACH table in row 0, column THD. Green is specified in row 1 and blue in row 2.

Click TEACH DATA TO in order to apply the current red, green and blue values to the table.

CONNECT		PARA1			PARA2	
TEACH	REC	CALIB	GEN	SCOPE		
	THD					
0	639	1	1	1	1	
1	641	1	1	1	1	
2	644	1	1	1	1	

Fig. 26 TEACH tab – THD

If a teach-in mode is selected under EXTEACH, you can teach the switching thresholds for red, green and blue using IN0.

When IN0 = HI, a maximum and a minimum value is determined for each channel.

The detected MIN-MAX values for the RED GRN BLUE channels are displayed in the RGB tab.

A switching threshold is calculated as follows: $THD = (Max + Min) / 2$. This means it is exactly in the middle between the maximum and minimum values.

Click GET to display the thresholds in the TEACH table.

If EXTEACH = ON, the switching thresholds are stored in the sensor's EE (EEPROM).

If EXTEACH = STAT1, the switching thresholds are stored in the sensor's RAM.

If EXTEACH = DYN1, the sensor first performs self-adjustment and then starts the MIN-MAX search. It then saves the switching thresholds to the RAM.

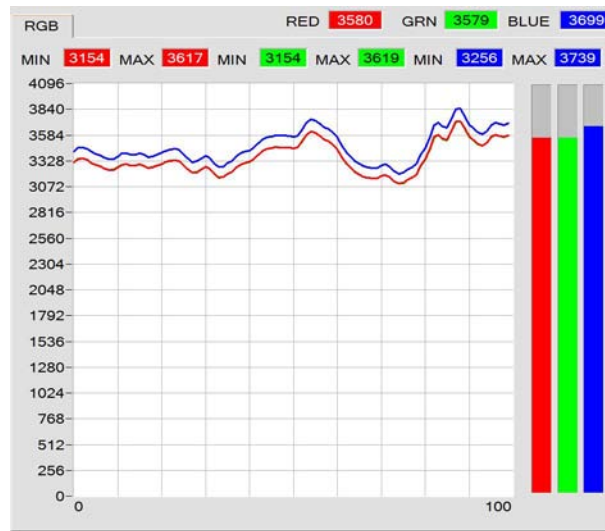

Fig. 27 Graph – RGB

Because the THD RGB mode is not an actual color evaluation, certain input and display elements are hidden (C-No.:, delta C, ...) or grayed out (TRIGGER, CALCULATION MODE, MAXCOL-No., ...).

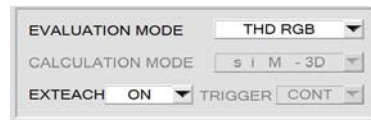

Fig. 28 PARA1 tab – EVALUATION MODE – THD RGB – EXTEACH ON

4.4.10 CALCULATION MODE



Fig. 29 PARA1 tab – CALCULATION MODE – X Y INT - 2D

4.4.10.1 X Y INT - 2D

The X/Y pairs of the individual red, green, and blue components and the intensity are used for evaluation. For X/Y a color tolerance CTO can be set, and for the intensity an INT tolerance ITO can be specified. With the individual tolerances the color can be represented as a cylinder in space, see Fig. 30. CTO defines the diameter of the cylinder and ITO the height of the cylinder.

4.4.10.2 s i M - 2D

The s/i pairs of the individual red, green, and blue components and M are calculated for evaluation. This calculation method follows the Lab calculation method. For s/i a color tolerance siTO can be set and for the intensity an M tolerance MTO can be specified. With the individual tolerances the color can be represented as a cylinder in space, see Fig. 30. siTO defines the diameter of the cylinder and MTO the height of the cylinder, see Fig. 30.

4.4.10.3 X Y INT - 3D

For evaluation, X, Y, and INT are calculated from the individual red, green, and blue components. These three values define a point in three-dimensional space. The specified tolerance value defines a sphere in space with radius TOL, see Fig. 30.

4.4.10.4 s i M - 3D

For evaluation, s, i, and M are calculated from the individual red, green, and blue components following the Lab calculation method. These three values define a point in three-dimensional space. The specified tolerance value defines a sphere in space with radius TOL in, see Fig. 30.

Calculation of coordinates:

	X Y INT	s i M
X s	X-value of the teach-in color (in the color triangle numerical value on the x-axis: RED color content)	s is calculated on the basis of the Lab color evaluation method.
	$X = \frac{R}{R + G + B} * 4095$	$s = 5000 * \left[\left[\frac{R}{4096} \right]^{1/3} - \left[\frac{G}{4096} \right]^{1/3} \right] + 5000$
Y i	Y-value of the teach-in color (in the color triangle numerical value on the y-axis: GREEN color content)	i is calculated on the basis of the Lab color evaluation method.
	$Y = \frac{G}{R + G + B} * 4095$	$i = 2000 * \left[\left[\frac{G}{4096} \right]^{1/3} - \left[\frac{B}{4096} \right]^{1/3} \right] + 2000$
INT M	Intensity value for the respective color.	M is calculated on the basis of the Lab color evaluation method.
	$INT = \frac{R + G + B}{3}$	$M = 1160 * \left[\frac{G}{4096} \right]^{1/3}$
CTO siTO	<p>In CALCULATION MODE “X Y INT” or “s i M - 2D”, CTO or siTO is the color tolerance radius around the taught X/Y or s/i pair. CTO or siTO defines the radius of the color cylinder in space. Within the thus defined tolerance circle the current color is recognized as the taught color.</p> <p>A color is recognized when delta C is less than CTO or siTO or when INT or M is in the intensity window that is defined by INT±ITO or M±MTO.</p>	
ITO MTO	<p>In CALCULATION MODE “X Y INT - 2D” or “s i M - 2D”, ITO or MTO is the intensity tolerance window around the respective taught intensity INT or M. ITO or MTO defines the height of the color cylinder in space. Within the thus defined tolerance window the current color is recognized as the taught color.</p> <p>A color is recognized when delta C is less than CTO or siTO or when INT or M is in the intensity window that is defined by INT±ITO or M±MTO.</p>	
TOL	<p>In CALCULATION MODE “X Y INT - 3D” or “s i M - 3D”, TOL is the tolerance radius around the taught point “X Y INT - 3D” or “s i M - 3D” in space. TOL defines the radius of the color sphere in space. Within this sphere the current color is recognized as the taught color</p> <p>A color is recognized if delta C is less than TOL.</p>	

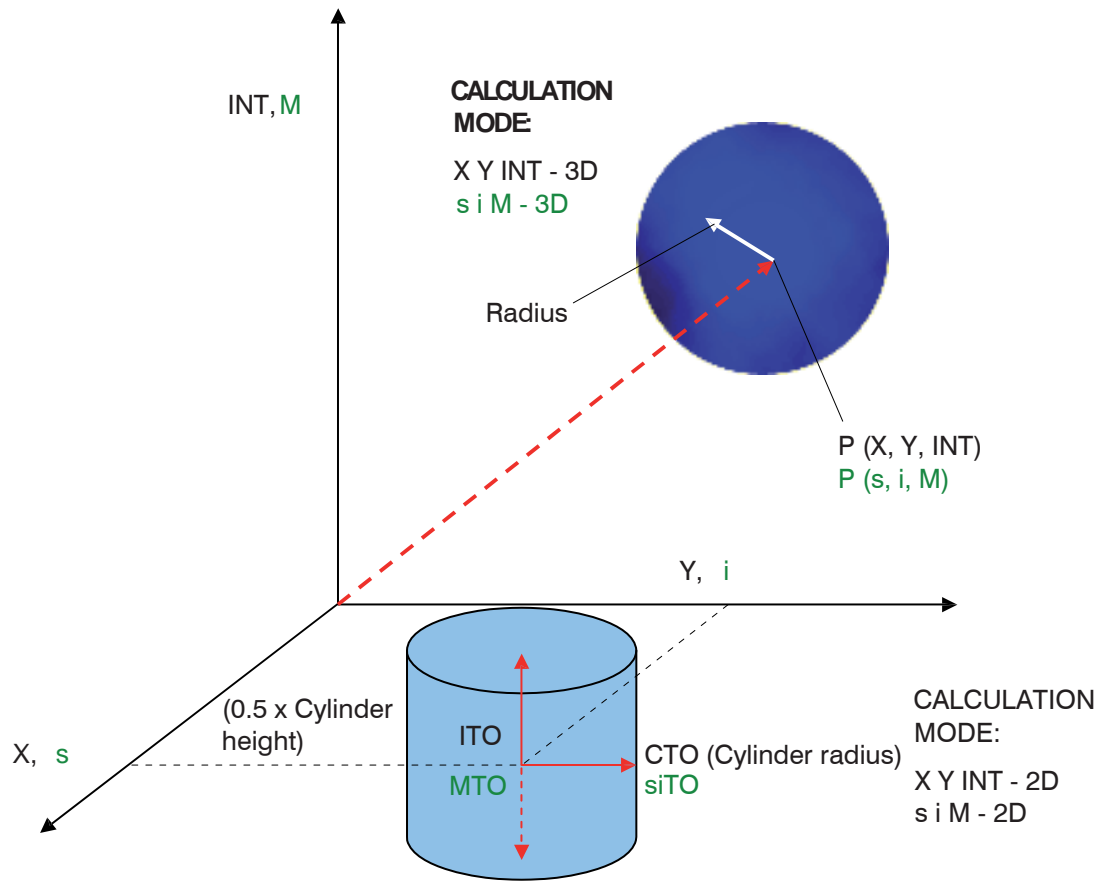

Fig. 30 Tolerance space models

4.4.11 TRIGGER



Fig. 31 PARA1 tab – TRIGGER - CONT



Fig. 32 Trigger event

This function field is used to set the trigger mode at the sensor. If TRIGGER is not CONT, the TRIG LED will indicate a trigger event, see Fig. 32

4.4.11.1 CONT

Continuous color detection (no trigger event required).

4.4.11.2 SELF

By selecting `SELF` the sensor can be operated in self-trigger mode.

The free status must be taught to row 0. For example, the free status

- is the uncovered status for a split optical fiber in transmitted-light operation.
- is the status when no part exists in reflected-light operation.

Color detection starts when row 0 is no longer detected (self-trigger). After the trigger event, i.e. when color 0 is detected again, the system outputs the teach-in color that was detected most frequently during triggering. When the sensor leaves row 0, row 0 will be output in accordance with the output mode.

When the sensor returns to row 0, an error will be output, or the system outputs the color that was present for the longest time. This means that a self-trigger event always results in a change of output states.

The same applies to `COLOR GROUP = ON`. When the sensor leaves group 0, group 0 will be output in accordance with the output mode. When it returns to group 0, an error will be output, or the system outputs the group that was present for the longest time. This means that even if an individual color was detected as present for the longest period it will not be output if, for example, two colors that belong to the same group were present for a longer time span. Several colors can also be combined into group 0 for the trigger condition because leaving group 0 determines the trigger condition.

After the trigger drops, an average value over `X Y INT` (or `sim`) and delta C is output once. The average is determined from all the color hits, except row 0, and can be acquired with `RECORD MODE = AUTO TRIGGERED`.

4.4.11.3 EXT1

Color detection is started through the external trigger input (IN0 pin3 green of CAB-M9-8P-St-ge; Xm-PUR; open) or by pressing the `TEACH` button at the sensor. After the trigger event, if `COLOR GROUP = ON`, the system outputs the color among the teach-in colors and groups that was detected most frequently during triggering.

In addition, an average over `X Y INT` (or `sim`) and delta C is output once. The average value is determined from all the color hits and can be acquired with `RECORD MODE = AUTO TRIGGERED`.

4.4.11.4 EXT2

Color detection is started through the external trigger input (IN0 pin3 green of CAB-M9-8P-St-ge; Xm-PUR; open) or by pressing the `TEACH` button. The correct color (color no.) is recognized as long as +24 V is present at input IN0 (HIGH active).

After the trigger input has reverted back to LOW, the state (color no.) that was last detected will be held at the outputs.

4.4.11.5 EXT3

Color detection is started through the external trigger input (IN0 pin3 green of CAB-M9-8P-St-ge; 2m-PUR; open) or by pressing the `TEACH` button. The correct color (color no.) is recognized as long as +24 V is present at input IN0 (HIGH active).

After the trigger input has reverted back to LOW, the error state (color no. = 255) is generated at the outputs.

4.4.11.6 TRANS

Color detection is started through the external trigger input (IN0 pin3 green of CAB-M9-8P-St-ge; Xm-PUR; open) or by pressing the `TEACH` button. The correct color (color no.) is recognized as long as +24 V is present at input IN0 (HIGH active).

After the trigger input has reverted back to LOW, the transmission source (lighting) is switched off.

4.4.11.7 PARA

If TRIGGER = PARA, see Fig. 33, then two sets of parameters can be stored in the sensor.

SET is used to select if the current parameters should be stored on the sensor's user interface as parameter set 0 or parameter set 1.

Either the external trigger input (IN0 Pin3 green at CAB-M9-8P-St-ge; Xm-PUR; open) or pressing TEACH communicates to the sensor which parameter set to use.



Fig. 33 PARA1 tab – TRIGGER – PARA

On the interface, LED TRIG represents the state for IN0. If this LED is dark, then IN0 = LO = 0 V and the sensor uses parameter set 0.

If this LED is green, then IN0=HI=+24 V and the sensor uses parameter set 1.

In order to follow the signal on the interface, you need to select either 0 or 1 (depending on TRIG SET) and click GET.

SET is only active when TRIGGER = PARA.

4.4.12 EXTEACH

All evaluation modes provide the option of teaching of a color externally through IN0 or by means of the button at the sensor housing.

4.4.12.1 OFF

The external teach feature is deactivated.



4.4.12.2 STAT1

In STATIC POWER MODE a color is taught to position 0 in the TEACH table.

POWER MODE is automatically set to STATIC. A fixed transmitter power value must be set with the POWER slider. After pressing the button at the sensor housing or after a positive signal (+24 V) at input IN0, the current color is taught to row 0.

The taught color is stored only in the RAM and not in the EE (EEProm) of the sensor.

4.4.12.3 DYN1

In DYNAMIC POWER MODE a color is taught to position 0 in the TEACH table, and evaluation is then performed statically.

Power mode is automatically set to STATIC. After pressing the button at the sensor housing or after a positive signal (+24 V) at input IN0, the transmitter power is set such that the sensor is in the dynamic range, which is defined by DYN WIN LO and DYN WIN HI. The current color is then taught to position 0 in the TEACH table, and the sensor continues to operate statically with the established power value.

The taught color is stored only in the RAM and not in the EE (EEProm) of the sensor.

i If EVALUATION MODE = FIRST HIT and EXTEACH = ON, the rows up to MAX-COL-No. are filled with the same teach values for STAT1 and DYN1.

4.4.12.4 ON

The sensor can be taught up to 31 colors through IN0 or the button at the sensor housing.

In evaluation mode FIRST HIT, the currently present color is taught to all active rows based on MAXCOL-No. .

In evaluation modes BEST HIT, MIN DIST and COL5, each individual row in the TEACH table can be taught using the button or IN0.

The example shows the external teaching of 4 colors in evaluation mode BEST HIT.

- ➡ Select EXTERN TEACH = ON.
- ➡ Adjust the POWER value to ensure that the sensor is not overloaded and that the signal arriving at the sensor is not too low.
- ➡ Select how many colors you wish to teach externally.
- ➡ Click the TEACH tab to switch to the TEACH table.
- ➡ Enter the tolerances for each color you want to teach.



Fig. 34 Para1 tab – MAXCOL-No.

CONNECT		PARA1		PARA2	
TEACH	REC	CALIB	GEN	SCOPE	
	X	Y	CTO	INT	ITO
0	1	1	50	1	50
1	1	1	50	1	50
2	1	1	50	1	50
3	1	1	50	1	50

Fig. 35 TEACH tab – Teach table

In this example, MAXCOL-No. = 4 was selected, i.e. the sensor should detect the color information that is stored in the first 4 rows of the TEACH table by means of external teaching through IN0. Since the sensor cannot calculate the tolerances for color circle (CTO) and intensity (ITO), these values must be entered once (in this case “200” at all places) and stored in the EE (EEPROM) together with MAXCOL-No. and with EXTEACH = ON.

- ➡ Now select the setting EE (EEPROM) in the function field, and click SEND.

From now on, the PC is no longer required as long as you only wish to teach colors up to the MAXCOL-No. and do not want to change tolerances.

i The taught colors can, of course, be displayed on the PC at any time. Colors that are taught with EXTEACH = ON, are stored in the sensor's EE (EEPROM) so that information will not be lost when the system is switched off. This function rather is intended for subsequent teaching as the sensor does not automatically adjust its POWER value.

Before the external teach process can be started, the color to be taught must be presented to the sensor.

The external TEACH process is started with a positive edge at IN0 (green wire) or by pressing the TEACH button. The output LEDs (OUT0 ... OUT4) will start flashing. From now on, the user has a certain number of seconds to inform the sensor about the position at which the color information (X Y INT) should be placed in the TEACH table. The period of time in which the user can teach this information to the sensor depends on the value specified in MAXCOL-No. (for example, approximately 5 seconds when MAXCOL-No. = 5).

The first positive edge (start edge 0) selects position 0 in the TEACH table. Every additional positive edge selects one position higher, see Fig. 36.

Example:

Perform the following steps if you want to save the current color to position 3 in the TEACH table:

Step 1:

➡ Start the external TEACH process with a positive edge (0) at IN0.

Position 0 is selected, the LEDs begin to flash.

Step 2:

An additional positive edge (1) selects position 1 in the TEACH table. Position 1 is indicated by the LEDs. The LED with binary value 1 remains at HIGH level all the time, while the other 4 LEDs continue flashing.

Step 3:

An additional positive edge (2) selects position 2 in the TEACH table. Position 2 is indicated by the LEDs. The LED with binary value 2 remains at HIGH level all the time, while the other 4 LEDs continue flashing.

Step 4:

An additional positive edge (3) selects position 3 in the TEACH table. Position 3 is indicated by the LEDs. The LEDs with binary value 3 remain at HIGH level all the time, while the other 3 LEDs continue flashing.

The desired position is now selected.

Step 5:

When the available time window is over, see Fig. 36 (LEDs stop flashing), the sensor starts the evaluation process.

- The time window available to the user is based on the setting for MAXCOL-No. .
- 1 With 4 colors, the available time is $4 \times 250 \text{ ms} = 1000 \text{ ms}$.

Step 6:

➡ Repeat step 1 to teach additional colors.

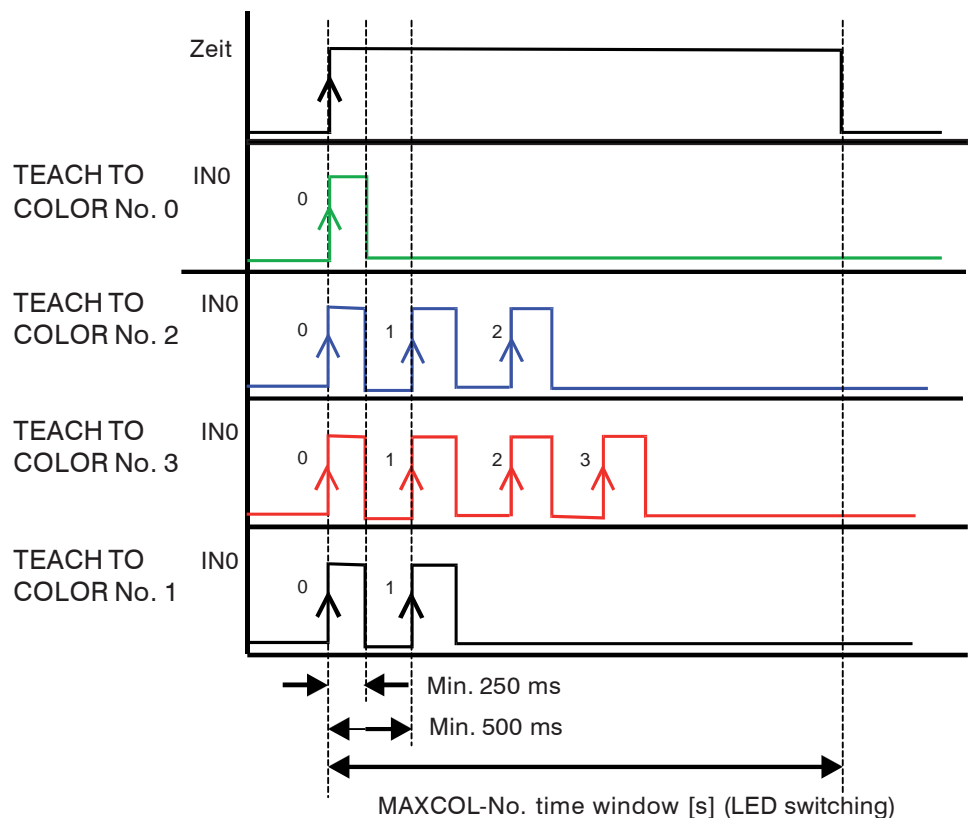

Fig. 36 Position selections in the TEACH table

4.5 PARA2 Tab

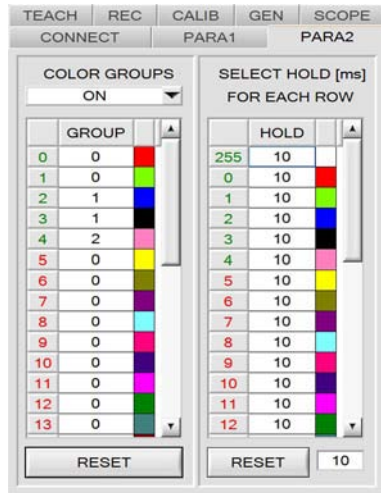

Fig. 37 PARA2 tab

➡ Select PARA2 tab.

This opens a view in which you can assign colors from the `TEACH` table to specific groups and where you can specify an explicit `HOLD` period for each color and each error state.

- You need to click `SEND` to communicate the color groups and `HOLD` settings to the sensor.

4.5.1 COLOR GROUPS

Color groups can be created in evaluation modes `FIRST HIT`, `BEST HIT` and `MIN DIST`. A separate table is used to assign the individual rows to a group.

In this example, `COLOR GROUPS` was set to `ON`, which means that group evaluation is active, see Fig. 37.

Rows 0 and 1 were assigned to group 0.

Rows 2 and 3 were assigned to group 1, and row 4 to group 2. A `GRP` input field appears under `C-No:`, see Fig. 38.



Fig. 38 PARA2 tab – Color number and group number

If, as in this example, row 3 is detected during evaluation, this row and the corresponding group are displayed, see Fig. 38.

The group number will be output through outputs `OUT0` to `OUT4`.

31 separate colors can be taught in evaluation modes `DIRECT HI` and `DIRECT LO`. However, a maximum of 5 groups may be created (group 0 to group 4).

A maximum of 31 groups can be created in `BINARY` evaluation mode (group 0 to group 30).

All cell values can be set to 0 by clicking `RESET`.

Double-click `GRP` to open an larger display window.

4.5.2 SELECT HOLD [ms] FOR EACH ROW - HOLD

The sensor operates with minimum scanning times of less than 100 μ s. This is why most of the PLCs that are connected to the digital outputs have difficulties to securely detect the resulting short switching state changes. Entering values in the table provides pulse lengthening at the digital outputs of the sensor system for up to 100 ms. Each individual row can be assigned its own HOLD time.

When you click RESET, the entire table is set to the reset value indicated next to the RESET button.

Example:

Print marks are transported at very high speed. The print marks are positioned in the sensor's range only for a very short time (milliseconds or even shorter). A minimum pulse of 10 ms is required for the reliable detection of a mark.

The background is taught to row 0, and the print mark to row 1. This is desirable because it allows the use of the BEST HIT evaluation mode.

The sensor will operate properly, if row 0 and row 1 overlap seamlessly. The output is immediately activated and remains active at least for the time specified in the corresponding row.

If row 0 and row 1 do not overlap, the sensor detects an error at the transition from row 0 to row 1 (print mark), which immediately is sent to the output and remains active at least for the HOLD time. An error inevitably would occur here if the selected HOLD value for the error state (255) was too high, because the sensor only outputs another status change after HOLD has elapsed (this may, but need not, be the print mark).

It is imperative to select a HOLD time of 0 for error state 255.

4.6 TEACH Tab

	s	i	siTO	M	MTO	
0	5008	2015	50	634	50	Red
1	5195	2061	50	700	50	Cyan
2	5045	2065	50	975	50	Blue
3	5003	1986	50	1010	50	Black
4	5056	1778	50	697	50	Yellow
5	5021	2057	50	1027	50	Green
6	5111	2253	50	1004	50	Purple
7	5229	2308	50	913	50	Magenta
8	5004	1974	50	894	50	Cyan
9	1	1	1	1	1	Red
10	1	1	1	1	1	Green
11	1	1	1	1	1	Blue
12	1	1	1	1	1	Yellow
13	1	1	1	1	1	Cyan
14	1	1	1	1	1	Magenta
15	1	1	1	1	1	Black

TEACH DATA TO No.: 1 Inc

TEACH MEAN TEACH REC RESET

Fig. 39 TEACH tab details

➡ Select the TEACH tab.

This opens a view, see Fig. 39, in which you can teach colors to the TEACH table.

The TEACH table is organized in rows, i.e. the individual parameters for the teach-in colors are arranged side by side in each row.

The sensor is able to check up to 31 teach-in colors. The number of the respective teach-in color is displayed in the left table column.

Only green rows are used for evaluation in the sensor. The number of rows to be checked is set with MAXCOL-No. .

➡ Click GO.

This starts the data transfer from the sensor to the PC. The respective red, green and blue contents are displayed as bars beside the graph. The calculated X, Y, INT or s, i, M values are visualized in the displays.

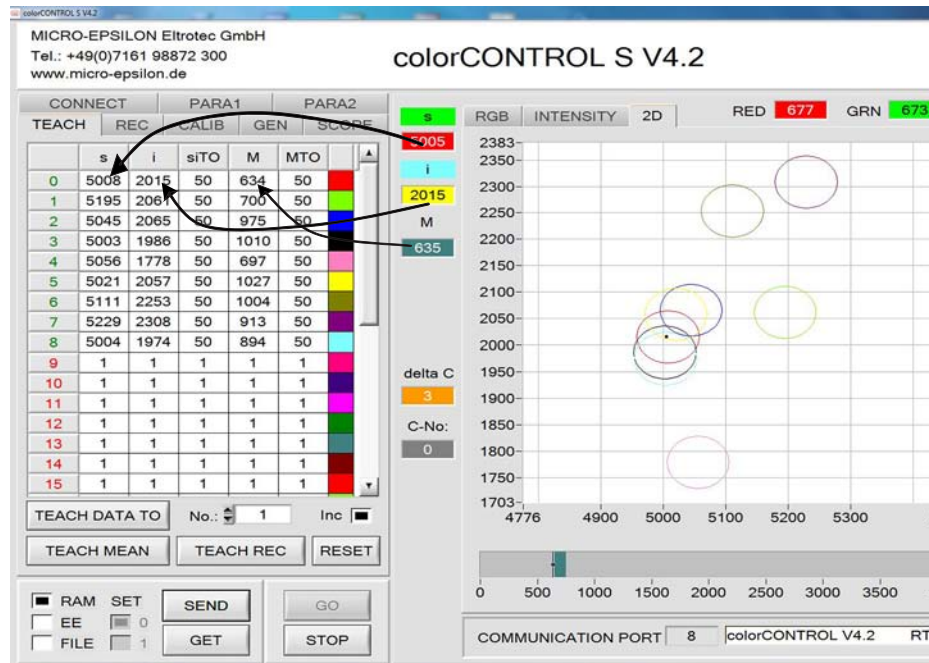

Fig. 40 TEACH tab with color space graph

4.6.1 X Y INT/ s i M

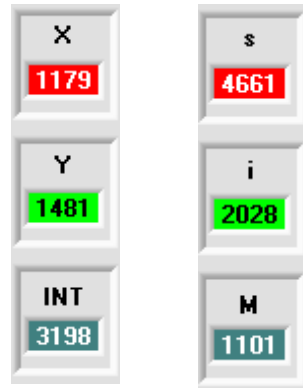

Fig. 41 PARA2 tab – X Y INT and S i M

4.6.1.1 X or s

This output field displays the numerical value of the red content (x-axis/s-axis) of the scattered light currently arriving at the receiver.

4.6.1.2 Y or i

This output field displays the green content (y-axis/i-axis) of the scattered light currently arriving at the receiver.

4.6.1.3 INT or M

This output field displays the currently measured intensity (proportional to the average of the intensities at the triple receiver).

4.6.2 C-No.

This output field displays the currently detected color number based on the entry in the TEACH table. The currently detected color number is sent to the digital outputs OUT0 ... OUT4 as a bit pattern.

Value 255 means that none of the taught colors is recognized.

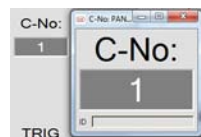

Fig. 42 PARA2 tab – Graph –Color number

Double-click the output field to open a larger output field, see Fig. 42.

i The above-mentioned output fields are only updated when the data transfer between PC and sensor is active (GO button enabled).

When you click TEACH DATA TO, see Fig. 39, the currently displayed data for X, Y, INT or s, i, M are transferred to the row in the TEACH table that is selected under No.. A color tolerance (CTO or siTO) and an intensity tolerance (ITO or MTO) is also set. If necessary, these tolerances, as well as the teach-in values, can be changed as described above.

You can modify fields within the TEACH table by double-clicking or by pressing F2. Use the PC keyboard to enter numerical values.

i To ensure proper color evaluation after teaching color values, you need to click SEND to communicate these values to the sensor.

The No. : input field is used to select the color number for teaching and to choose which INT or M tolerance window is shown in the respective graphs for the intensity or for M.

When Inc: is activated and you click TEACH DATA TO, the No. : input field is automatically incremented (increased) by 1, i.e. the next row in the TEACH table is selected.

Click `RESET TABLE` to reset the `TEACH` table (reset value = 1).

With `Set selection to` you can enter a value into multiple cells in the `TEACH` table.

	s	i	siTO	M	MTO	
0	5008	2015	50	634	50	Red
1	5195	2061	50	700	100	Green
2	5045	2065	50	975	150	Black
3	5003	1986	50	1040	200	Blue
4	5056	1778	50	250	250	Pink
5	5021	2057	50	1027	50	Yellow
6	5111	2253	50	1004	50	Light Blue
7	5229	2308	50	913	50	Purple
8	5004	1974	50	894	50	Cyan

Fig. 43 `TEACH` tab – `Set selection to`

You need to select the cells for modification, see Fig. 43.

Perform a right-click to open a popup window, see Fig. 43.

➡ Click `Set selection to`, see Fig. 43.

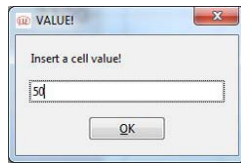

Fig. 44 `TEACH` tab – `Popup window`

Another popup window opens, see Fig. 44, in which you enter the new value for these cells.

In order to enter ascending tolerances, you need to select `Increment selection with` in the popup menu for `Set selection to`, see Fig. 43.

	s	i	siTO	M	MTO	
0	5008	2015	50	634	50	Red
1	5195	2061	50	700	100	Green
2	5045	2065	50	975	150	Black
3	5003	1986	50	1040	200	Blue
4	5056	1778	50	250	250	Pink
5	5021	2057	50	300	300	Yellow
6	5111	2253	50	350	350	Light Blue
7	5229	2308	50	400	400	Purple
8	5004	1974	50	450	450	Cyan

Fig. 45 `TEACH` tab – `Increment selection with`

The top left cell contains the starting value. Based on this cell, the values in the following cells are increased by the value which is entered in the popup window, see Fig. 45.

Use `Reset selection` to set the selected cells to 1.

For `TEACH DATA TO` the software suggests tolerance values and completes the corresponding rows automatically.

You can switch this feature on or off by selecting `TEACH Tolerance off`, see Fig. 46 or `Teach tolerance on`.

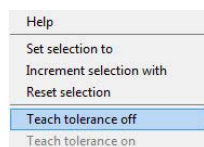

Fig. 46 `TEACH` tab – `Teach tolerance off`

➡ Click `HELP`.

This opens a popup window with explanations about the individual features.

➡ Click `TEACH MEAN VAL`.

The following window opens, see Fig. 47:

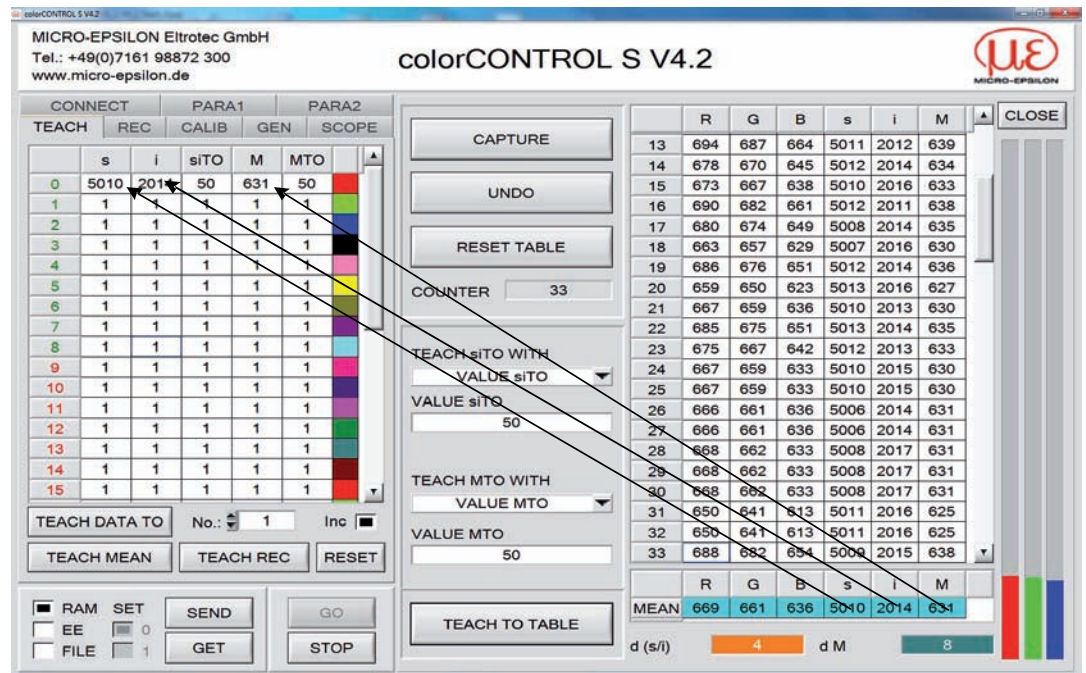

Fig. 47 TEACH tab – 2

The TEACH panel can be used in every EVALUATION and CALCULATION MODE. The example used here for explanatory purposes is based on EVALUATION MODE = BEST HIT and CALCULATION MODE = s i M - 2D.

Data are automatically gathered from the sensor and displayed.

➡ Click CAPTURE.

A parameter frame is entered into the table.

The COUNTER display field shows how many frames have already been recorded. Use UNDO to delete the last frames that were entered in the table.

RESET TABLE sets the entire table back to 0.

After every activation of CAPTURE, UNDO or RESET TABLE, the mean values for the individual parameters are calculated automatically and displayed in the mean value table.

The system also calculates a maximum color deviation $d(s/i)$ or $d(X/Y)$ and a maximum intensity deviation dM or $dINT$ from the average values.

Clicking TEACH TO TABLE teaches the respective mean values to the row in the TEACH table that is selected under ROW No. : (TEACH tab).

Teaching of the circular tolerance and intensity tolerance can be configured via TEACH sITO WITH and TEACH MTO WITH.

- If the setting is VALUE sITO, the value that is specified under VALUE sITO will be taught (the same applies to the intensity).
- If the setting is $d(s/i)$, the value that is determined based on $d(s/i)$ will be taught (the same applies to the intensity).
- If the setting is $d(s/i) + \text{VALUE sITO}$, the value that is determined based on $d(s/i)$ plus VALUE sITO will be taught (the same applies to the intensity).
- With NO CHANGE, the value specified in the TEACH table will remain unchanged.

A click on the CLOSE button will take you back to the main panel in the TEACH tab, see Fig. 40. Click TEACH REC VAL (teach recorded values) to open a panel which, after a click on the START button, begins to record data and displays them in the three graphs, see Fig. 48. This function is useful if the material to be detected cannot be directly placed in front of the sensor, for example when it is transported on a conveyor belt that cannot be stopped or cannot be exactly stopped at the position required for teaching. After some time, area centers will become apparent that can be assumed to be the objects for teaching.

The screenshot below shows 5 of these centers, see Fig. 48.

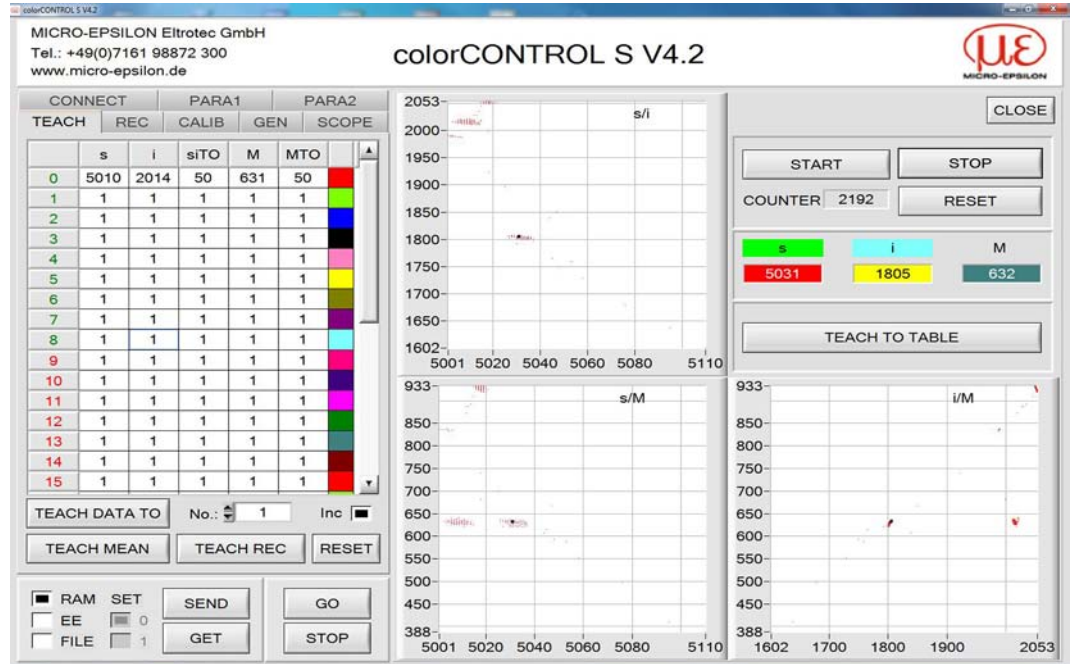

Fig. 48 TEACH tab – Rec Val

After clicking **STOP**, the cursor can be positioned on such an area center in any of the graphs. The cursor will be automatically positioned in the other two graphs.

Use **TEACH TO TABLE** to transfer the current cursor position to the **TEACH** table. Teaching will be performed to the row specified under **ROW No. : .**

Use **RESET** to reset the graphs and the counter.

A click on the **CLOSE** button will take you back to the main panel in the **TEACH** tab, see Fig. 40.

4.7 GEN Tab

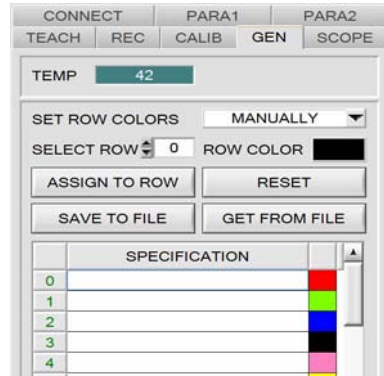

Fig. 49 GEN tab

➡ Select the GEN tab.

This opens a view which shows the current temperature value TEMP in the sensor housing. Please note that the value is neither Celsius nor Fahrenheit, see Fig. 49, see Fig. 50.



Fig. 50 GEN tab – TEMP

On the GEN tab you can select the row color for visualizing the individual tolerance circles, or you can specify that this color is set automatically based on the color detected by the system.

In addition, you can enter designations for each row into the SPECIFICATION table. These designations are stored on the PC hard drive and loaded as required.

If SET ROW COLORS is set to MANUALLY, you specify under SELECT ROW which row color to change. Click the color field for ROW COLOR to open a color palette, and select the desired color.

Click ASSIGN TO ROW to display the color in the 6th column and the selected row in the TEACH table.

If SET ROW COLORS is set to AUTOMATICALLY, the system computes the corresponding row color and displays it in a color display panel next to the graph. When you click TEACH DATA TO, the system assigns this color to the relevant row.

You can use SAVE TO FILE and GET FROM FILE to save specific row color arrays and the SPECIFICATION table to the hard drive or load saved arrays.

Click RESET to reset the color to a default value.

The ROW COLOR and SPECIFICATION tables that were in use when exiting the software are loaded when the software is restarted.

4.8 REC Tab

The colorCONTROL S software features a data recorder that allows to save data which the sensor has read and computed. The recorded file is saved on the PC and can then be evaluated with a spreadsheet program.

The file that is created has 13 columns and as many rows as data frames were recorded. A row is structured as follows: date, time, RED, GREEN, BLUE, X, Y, INT, delta C, TEMP, COLOR, GROUP, TRIGGER.

i Recording details depend on which EVALUATION MODE was selected. A number of EVALUATION MODES do not need certain data, therefore these data will be set to 0, i.e. for these data the value 0 will be recorded.

➡ Perform the following steps to record data frames using the recorder:

Step 1:

➡ Select the REC tab.

This opens the following window:

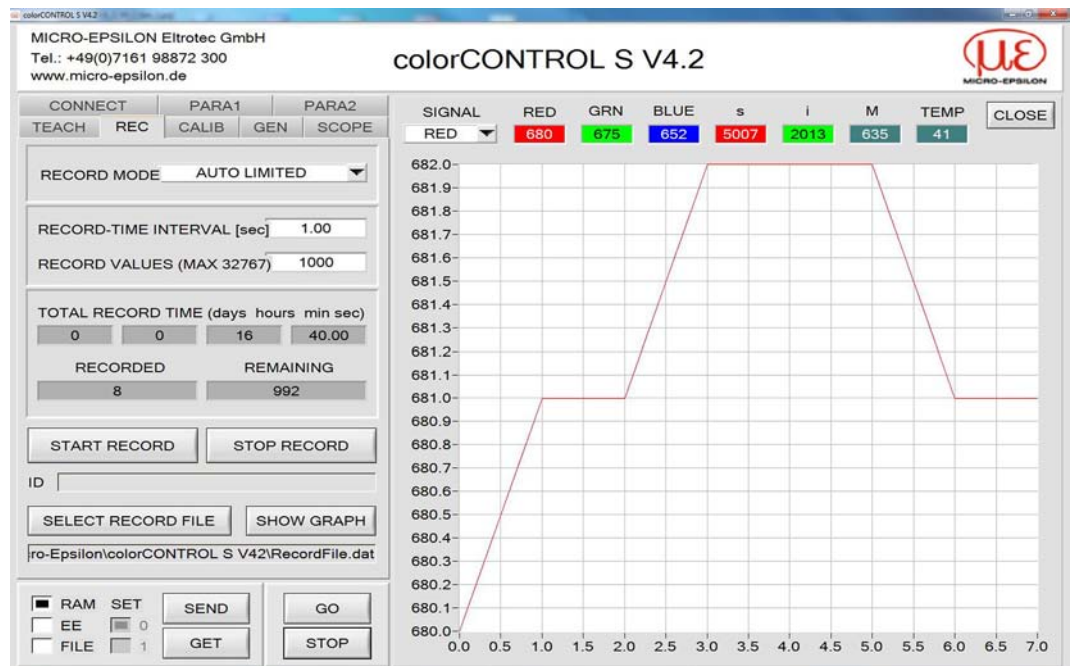

Fig. 51 REC tab

➡ Click SHOW GRAPH.

This opens a panel in which the user can record the various signals, see Fig. 51. Use the SIGNAL dropdown menu to switch between the individual signals (RED, GREEN, BLUE, s, i, M, TEMP).

Step 2:

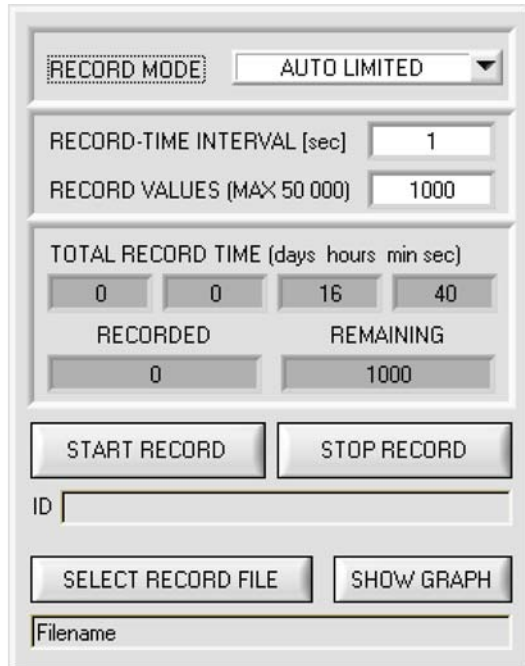

Fig. 52 REC tab – Details

- To automatically record several data frames, select `AUTO LIMITED` under `RECORD MODE`.
- Enter a time interval for recording under `RECORD-TIME INTERVAL [sec]`. This example uses 1, which means the sensor requests a new value every second.
- Now enter the maximum number of values you wish to record under `RECORD VALUES [MAX 32767]`.

i Recording can also be stopped by clicking `STOP RECORD`, and the data recorded so far will not be lost.

The `TOTAL RECORD TIME` field indicates how long recording will take (in days, hours, minutes, and seconds) if all data are recorded.

Step 3:

- Click `SELECT RECORD FILE` to select a file in which the data frame will be stored. If you select an existing file name, you will be asked whether you want to overwrite the existing file.

Step 4:

- Click `START RECORD`.

This starts automatic data recording.

The recorder starts to record data, and the button `START RECORD` is red to indicate that recording is active.

The respective data frames are shown in the display windows.

In the two display fields `RECORDED` and `REMAINING` you can check how many data frames have been recorded and how many frames remain to be recorded.

i During recording the two input fields `RECORD-TIME INTERVAL` and `VALUES TO BE RECORDED` are inactive.

Step 5:

When the number of data frames specified under RECORD VALUES [MAX 32767] have been recorded, or when you click STOP AUTO RECORD, a popup window will appear which confirms that the file is stored.

➡ If you want to record an unlimited number of data, select AUTO UNLIMITED under RECORD MODE.

➡ Then select the desired recording interval and click START RECORD.

➡ If you want to record data manually, select the MANUAL RECORDING option under RECORD MODE.

Click GO to start reading data from the sensor. These data are visualized in the display window. Clicking the CAPTURE DATA FRAME button saves a data frame in the file that was selected under SELECT RECORD FILE. The RECORDED field shows the number of frames already recorded.

If AUTO TRIGGERED is selected under RECORD MODE and TRIGGER = SELF, EXT1, EXT2, EXT3, TRANS or PARA, the sensor will automatically send a data frame after each drop of the trigger after you click START RECORD. This data frame is captured and recorded by the recorder.

Clicking STOP RECORD terminates the automatic sending function of the sensor.

i When you click START RECORD, the file that is selected under SELECT RECORD FILE will be deleted. With RECORD FRAME MANUALLY, the file will be created if it does not already exist. If the file already exists, the data are added to the existing file.

4.9 CALIB Tab

4.9.1 White Light Balancing

The sensors of the colorSENSOR LT or colorSENSOR OT series can be used to perform white light balancing on any white surface. A ColorChecker™ table with 24 color fields in line with the CIE standard is available as an alternative, and white light balancing or calibration can then be performed to one of the white fields.

➡ Select the CALIB tab.

This opens the following window:

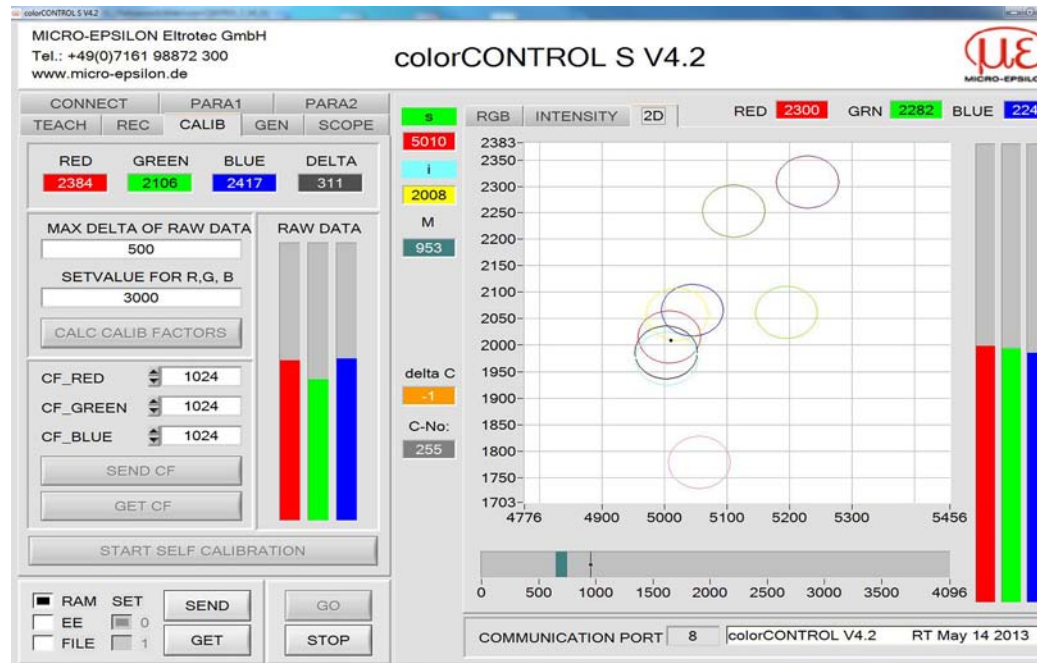

Fig. 53 CALIB tab

Calculation example for determining the calibration factors:

In the example formula below, see Fig. 54, a POWER value has been set which ensures that the three bars of the RAW DATA raw signals are in the dynamic range. Each of the three bars is at approx. 3300 digits. Now enter a setpoint value of 3000 for the three bars into the SETVALUE FOR R, G, B input field. When you start calibration by clicking CALC CALIB FACTORS, the software automatically calculates the calibration factors for channel RED, channel GREEN and channel BLUE. The calibration factors are normalized as integers to the value 1024.

$$CF_RED = (SETVALUE / RAW DATA RED) * 1024 = (3000 / 3056) * 1024 = 1008$$

$$CF_GREEN = (SETVALUE / RAW DATA GREEN) * 1024 = (3000 / 2705) * 1024 = 1140$$

$$CF_BLUE = (SETVALUE / RAW DATA BLUE) * 1024 = (3000 / 3274) * 1024 = 942$$

Fig. 54 Formula used in the calculation example for determining the calibration factors

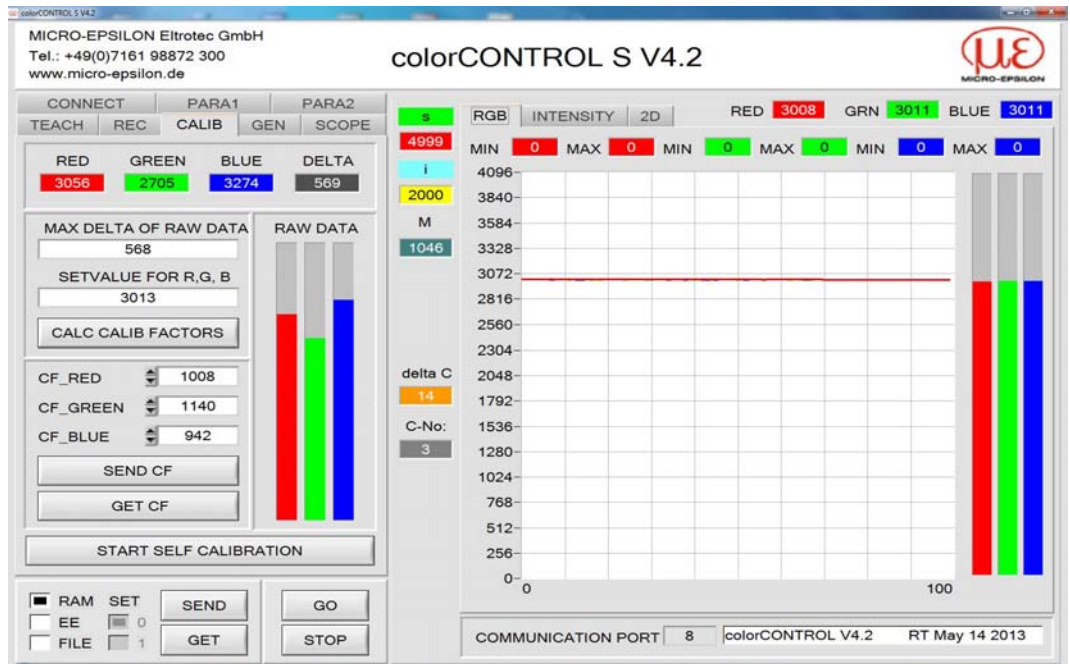

Fig. 55 Calibration example

When the software has calculated the calibration factors on the user interface, they are automatically saved to the non-volatile **EE** (EEPROM) memory of the sensor. Calibration is now finished, and work can continue on the **TEACH** tab.

Example:

When the sensor detects a raw signal, it applies the calibration factor saved in the **EE** (EEPROM) to this raw signal, and only the calibrated data for the RED, GREEN, and BLUE channels are displayed in the main panel of the **TEACH** tab. The micro-controller also uses only calibrated data for evaluation.

Below please find the steps for sensor calibration.

- The individual popup windows are intended to guide you through the calibration process.
- ➔ Direct the sensor to a white surface at the same distance that will subsequently be used for testing.

This helps to ensure successful calibration.

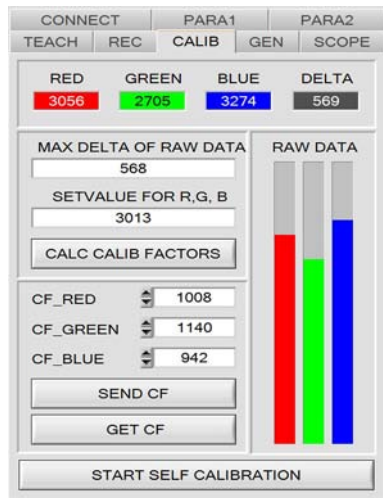

Fig. 56 CALIB tab

Step 1:

A suitable POWER value must be found which ensures that the RAW DATA for RED, GREEN and BLUE lie in the dynamic range, see Chap. 4.4.1.2.

Step 2:

➡ After setting a suitable POWER value, specify a SETVALUE FOR R,G,B.

The software now calculates the calibration factors using the raw data to arrive at the SETVALUE, see Fig. 54.

Step 3:

➡ Determine a MAX DELTA OF RAW DATA.

The software suggests a value of 500.

Calibration is only permitted, if the current DELTA of the RAW DATA is less than the MAXI DELTA OF RAW DATA.

DELTA is the maximum of RED, GREEN and BLUE minus the minimum of RED, GREEN and BLUE. This is required in order to ensure that the sensor functions properly and calibration is performed on a white surface.

Step 4:

➡ Click CALC CALIB FACTORS.

The calibration process begins.

The button starts to flash in red. At the same time 100 raw data are recorded through the interface used to calculate the respective mean values for RED, GREEN, and BLUE.

The individual calibration factors are created from these mean values and from the SET-VALUES FOR R,G,B. They are then entered in the corresponding input fields.

The calibration software automatically stores the calculated calibration factors in the sensor's EE (EEPROM) memory.

The software then switches to GO mode and displays the RAW DATA and the calibrated data in the main panel of the CALIB tab.

ⓘ Please note that the values for RED, GREEN, and BLUE in the main panel of the CALIB tab approximately are equal to the value of SETVALUE.

You may also change the calibration factors CF_RED, CF_GREEN and CF_BLUE manually by entering new values into the corresponding input fields.

ⓘ Please note that these factors are saved to the EE (EEPROM) by clicking SEND CF.

GET CF reads the calibration factors that are currently saved in the EE (EEPROM).

➡ If clicking CALC CALIB FACTORS is not successful, please follow the information provided in the popup windows.

Calibration only is completed successfully, if the following popup window is displayed:



Fig. 57 Popup window "CALIBRATION PASSED"

➡ Click **START SELF CALIBRATION**.

The sensor starts calculating its calibration factors automatically.

You cannot specify **SETVALUE** or **MAX DELTA**.

After the sensor has successfully calculated the calibration factors, it displays them on the interface. The sensor also shows the **SETVALUE** that was used for calculation and the **MAX DELTA** value that is the result of the calculation in the corresponding fields.

➡ Accept the calculated calibration factors by clicking **SEND CF**.

4.9.2 Offset Calibration

To avoid an increase of the electronic offset when using the integral function (**INTEGRAL** parameter), this offset can be eliminated by way of offset calibration or zero-point calibration. The corresponding tab is password protected to prevent inadvertent incorrect settings.

➡ Double-click with the right mouse button anywhere between the individual elements in the **CALIB** tab.

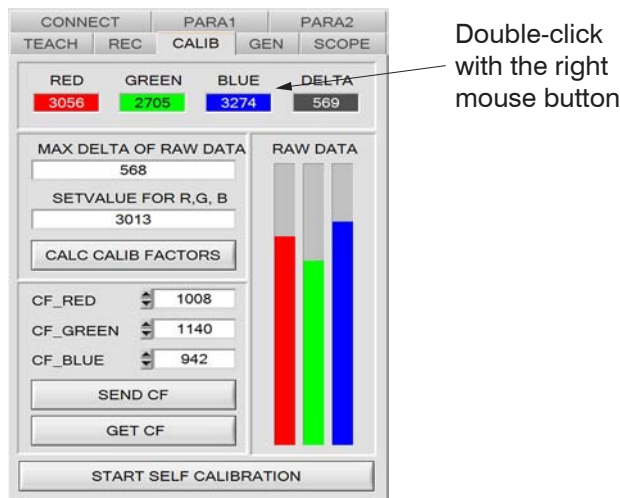

Fig. 58 CALIB tab – Offset calibration options

The Password Panel dialog box displays.



Fig. 59 Dialog box “Password Panel”

➡ Enter the password **mellon**.

Now please follow the instructions provided in the tab, see [Fig. 60](#).

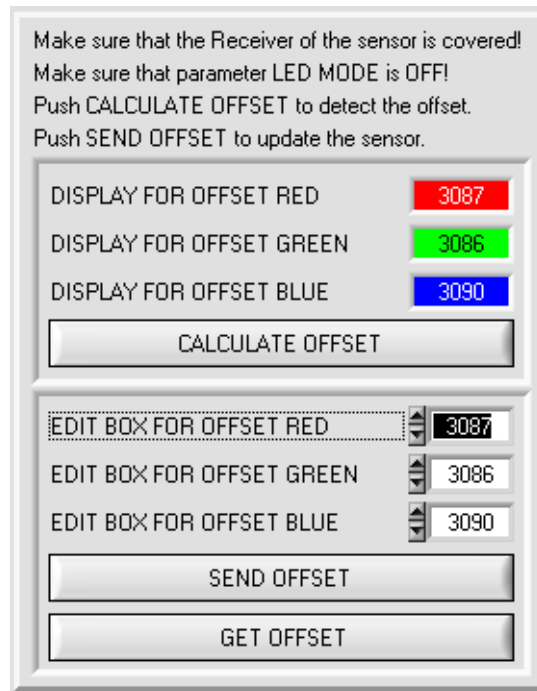

Fig. 60 CALIB tab – Offset calibration

- To ensure correct offset calibration for color sensors, it is imperative that no extraneous light reaches the receiver.
 - ➔ Cover the receiver of the sensor with a black cloth that is impermeable to light or a similar object.
 - ➔ Now click CALCULATE OFFSET.
 - The offset values for red, green, and blue should be approximately 3080 plus/minus 40.
 - ➔ Now click SEND OFFSET.
- The offset values are sent to the sensor.
- GET OFFSET can be used to check whether the data have been sent successfully.

4.10 SCOPE Tab

The SCOPE tab emulates an oscilloscope.

Select TRIG MODE to display the R G B or X Y INT / s i M signals, the state of the digital outputs and the state of the digital input IN0.

➡ Click GET CYCLE TIME.

The current sensor scan frequency is displayed in [Hz] and [ms]. This frequency is required to correctly calculate deltaX [ms].

You need to wait 8 seconds while the sensor determines the correct scan frequency before you click GET CYCLE TIME.

- If TRIG MODE = SINGLE SHOT, clicking SCAN initiates the recording of a data frame which is then displayed in the graph.
- If TRIG MODE = FALLING EDGE or RISING EDGE, you can start a triggered recording by clicking SCAN. You can use TRIGGER LEVEL to specify a trigger start signal. Triggering is performed for BLUE, INT or M, depending on which signal to record (R G B or X Y INT / s i M). This corresponds to the blue line in the graph.
- If TRIG MODE = INTERN C-No. 0, recording starts automatically as soon as C-No. 0 is detected.
- With TRIG MODE = EXTERN IN0, recording is started externally using input IN0.
- Use SCAN RATE to slow down or accelerate recording, similar to the TIMEBASE feature of oscilloscopes.
- Use PRE TRIGGER VALUES to specify how many values are displayed before triggering is started.

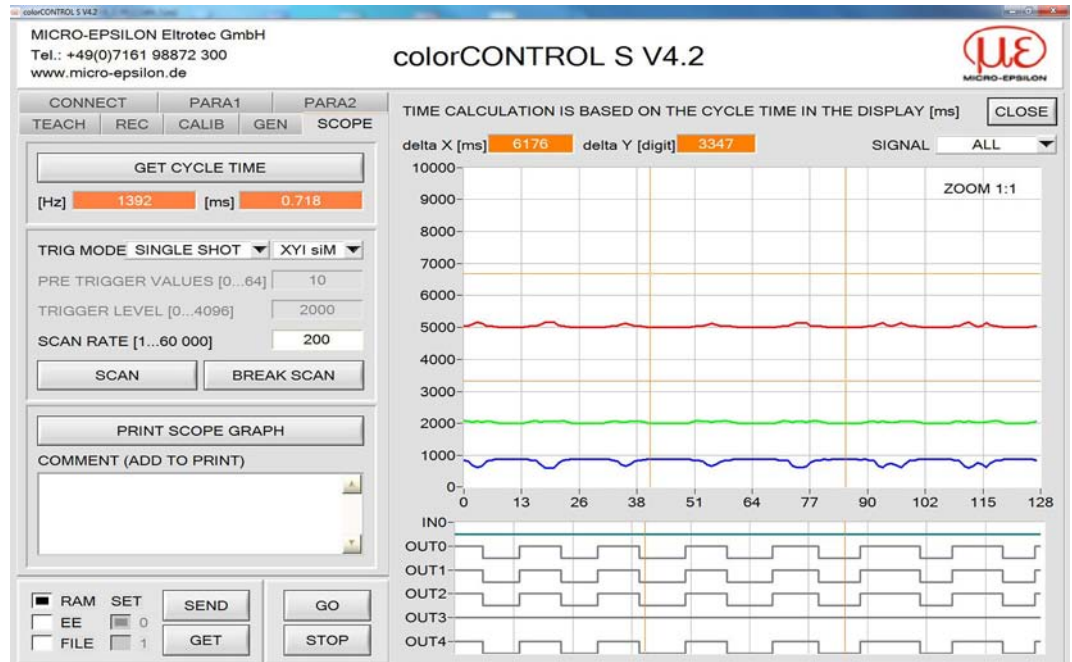

Fig. 61 SCOPE tab

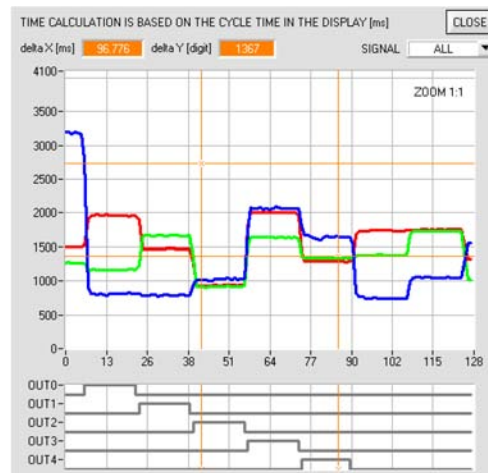

Fig. 62 Details from the SCOPE tab

- Press CTRL and simultaneously draw a window within the graph using your mouse to zoom into the graph.
- Select "ZOOM 1:1" to cancel zooming.
- You can move the two orange cursors with your mouse which updates the display for deltaX[ms] and deltaY[digit].
- `deltaX[ms]` indicates the time between the cursors in X-direction.
- `deltaY[digit]` indicates the difference between the two cursors in Y-direction in digits.
- Specify SIGNAL to display individual curves, see Fig. 62.
- PRINT SCOPE GRAPH prints the current screen including any text in the COMMENT text field, see Fig. 61.

4.11 Graphic Display Elements

RGB tab:

Displays the current raw signals of the triple receiver (red, green, blue).



INTENSITY tab:

Displays the current intensity INT or M.

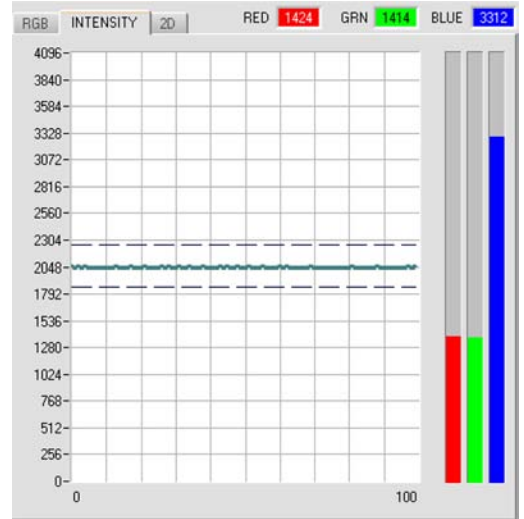

2D tab:

A zoomed graph displays X/Y or s/i pairs. Intensity INT or M with the tolerance window set under No. : is shown directly below.

Two-sided view of the color cylinder in space.

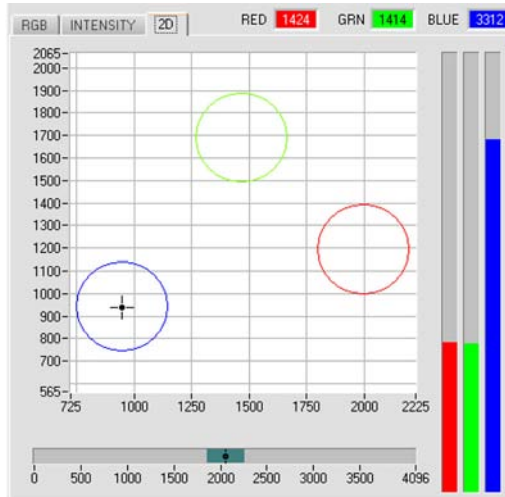

3D tab:

Displays the taught color spheres and the current color position. For improved representation, a three-sided view was selected that includes the graphs X/Y (s/i), X/INT (s/M) and Y/INT (i/M).

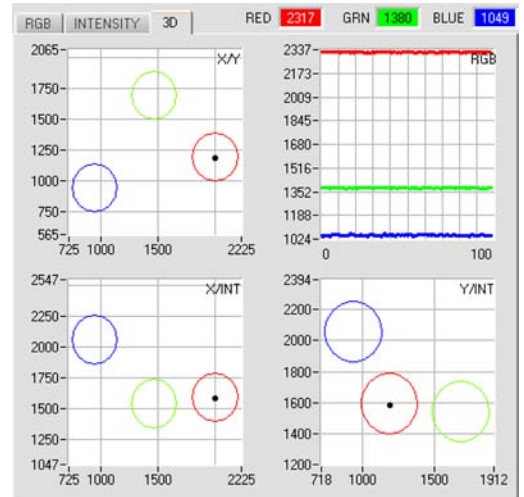

4.11.1 Delta C



Fig. 63 Output field “delta C”

This output field, see Fig. 56, see Fig. 63, shows the deviation from a color hit; delta C corresponds with ΔE which is calculated in a color measurement.

In FIRST HIT evaluation mode, delta C represents the distance from a color hit. If there is no color hit, delta C is calculated based on the last valid color from the color table (depending on MAXCOL-No.).

In the BEST HIT and MIN DIST evaluation modes, delta C also represents the distance from a color hit. If, however, no color was recognized, delta C assumes the value of -1. In COL5 evaluation mode, delta C is not calculated.

If the current intensity (INT or M) falls below the INTLIM parameter, delta C = -1 will be displayed.

In CALCULATION MODE XY INT - 2D and s i M - 2D, delta C represents the distance from the cylinder axis and is calculated as follows:

$$\text{deltaC} = \sqrt{X^2 + Y^2} \quad \text{or} \quad \text{deltaC} = \sqrt{s^2 + i^2}$$

In CALCULATION MODE XY INT - 3D and S i M - 3D, delta C represents the distance to the center of the sphere.

$$\text{deltaC} = \sqrt{X^2 + Y^2 + \text{INT}^2} \quad \text{or} \quad \text{deltaC} = \sqrt{s^2 + i^2 + M^2}$$

Appendix

A 1 Quick Reference Guide for the Operation of Color Sensors

These instructions describe how to perform fast teaching operations for color sensors of the colorSENSOR LT-3 and colorSENSOR OT-3 series with the software application colorCONTROL S.

Basically there are 2 methods of teaching a color. These methods can be specified with CALCULATION MODE.

CALCULATION MODE X Y INT - 3D (or s i M - 3D) uses a color sphere with radius TOL in space. CALCULATION MODE X Y INT - 2D or s i M - 2D on the other hand uses a color cylinder with radius CTO or siTO and with height ITO or M in space, see Fig. 64.

The teach-in procedure is the same for both methods.

Color evaluation for s i M is based on the Lab method of calculation.

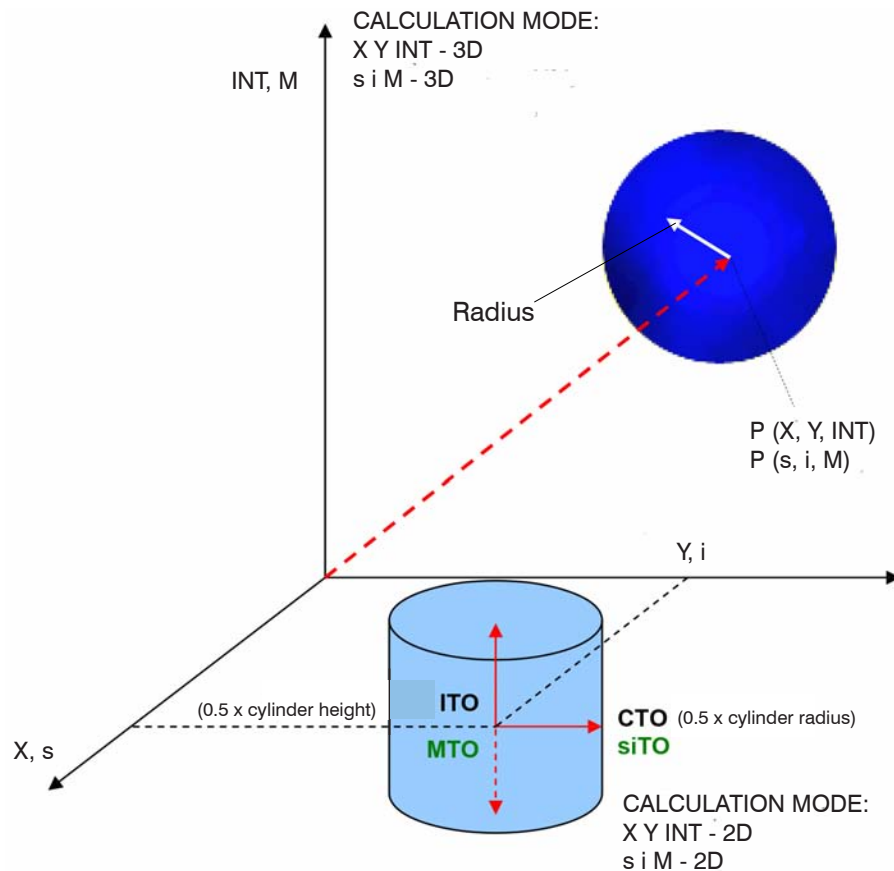

Fig. 64 2D and 3D tolerance models

The following section describes a teach-in procedure with EVALUATION MODE = BEST HIT and CALCULATION MODE = X Y INT - 3D.

Step 1:

Before using software aids (graphic display of sensor signals), the sensor must be manually adjusted to the respective target or background as accurately as possible. You will find the reference distance between sensor and target in the data sheet for your sensor.

Please make sure that the sensor is properly connected and supplied with power. The brightest surface (paper, leather, glass, etc.) of the teach-in color must be placed in front of the sensor. This is imperative to be able to set a suitable POWER value for the sensor.

Step 2:

Start the colorCONTROL S software. Please check whether the status line at the bottom right displays the “colorCONTROL S xx xxx xx xxxx” message.

- i Moving the mouse cursor to a control element and clicking with the right mouse button displays a quick info about the control element.

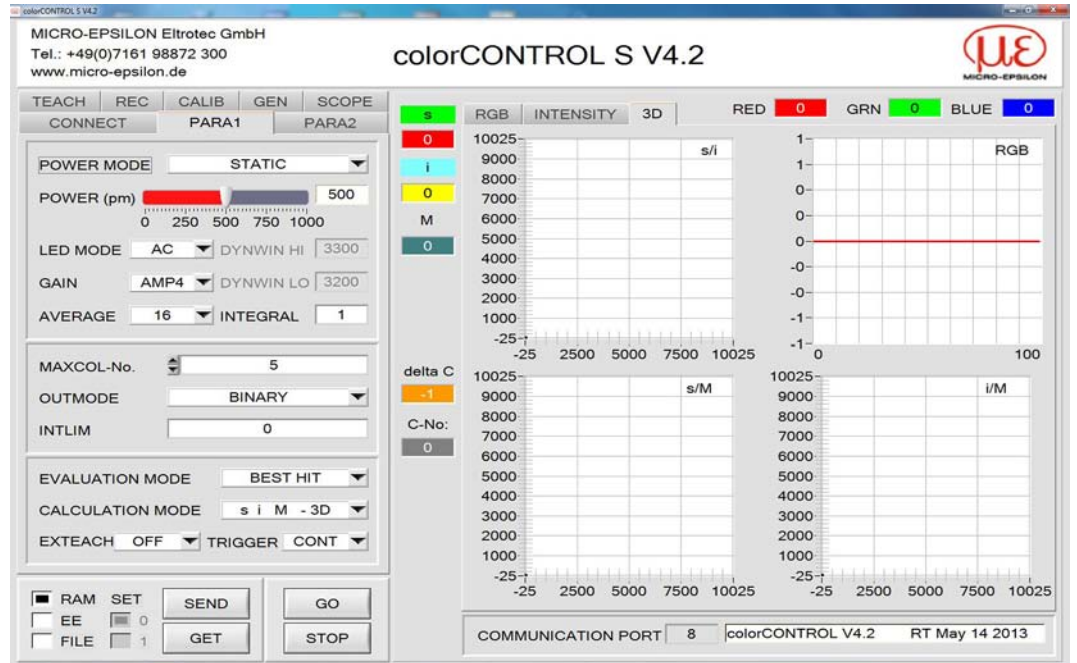

Step 3:

Please make sure that you have selected RAM and not EE (EEProm) for the data exchange with the sensor. RAM is a volatile memory in the sensor, i.e. the data will be lost when power is turned off. EE (EEProm) is a non-volatile memory in the sensor, i.e. the data will not be lost when power is turned off.

All the other parameters should be set as shown in the image below, see Fig. 65.

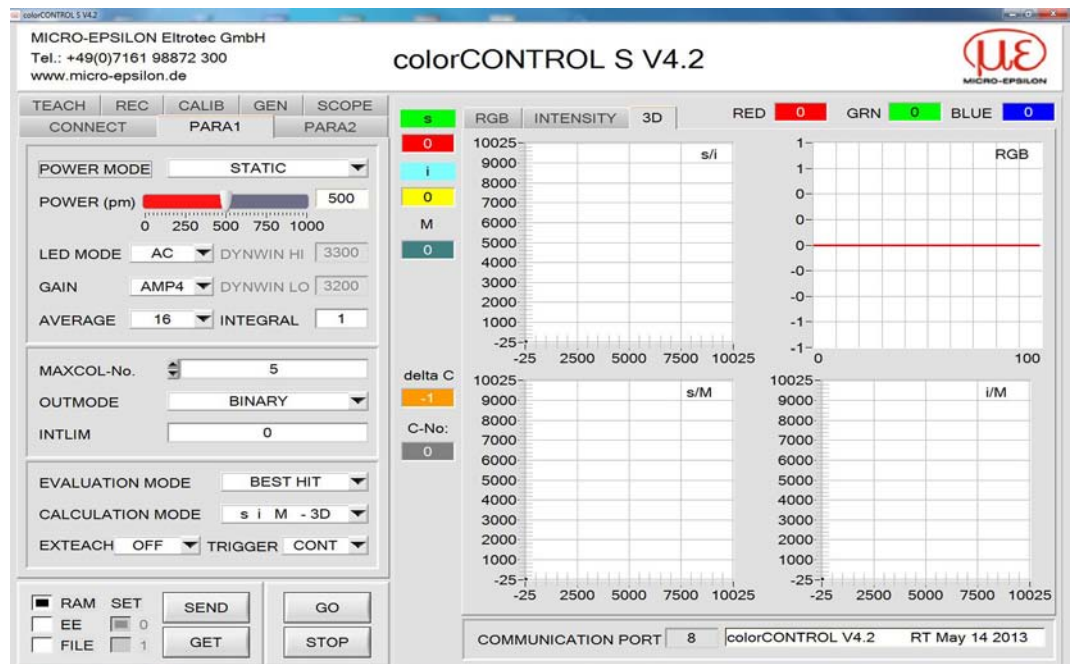

Fig. 65 Para1 tab – Main panel

➡ Select the `PARA1` tab to display the parameters (see also `FILE` feature).

➡ Now click `GO`.

This starts the data exchange between sensor and PC. The `RED`, `GREEN`, and `BLUE` contents which are diffusely reflected from the surface are represented in a graph and in display windows on the software interface.

➡ Set the `POWER` and `GAIN` values so that at least one of the three channels for the brightest teach-in color is in the upper third of its dynamic range, but none of them is in saturation.

Ideally, `POWER` and `GAIN` are set to ensure that `POWER` is in the range between 300 and 900.

ⓘ Any changes to the `POWER` or `GAIN` value must be communicated to the sensor.

➡ To do this, click `SEND`.

➡ Click `GO` again to check the bars.

➡ Repeat this process until you have suitable `POWER` and `GAIN` values.

Ideally, the three bars should be at approximately the same level on a white target/paper. If they vary too much, you may need to perform white light balancing, see Chap. 4.9.1.

There is a trick to quickly finding a suitable `POWER` value:

➡ Place the lightest color for recognition in front of the sensor.

➡ Set `POWER MODE = DYNAMIC`.

The sensor then tries to find a suitable `POWER` value.

➡ Click `SEND` to communicate the change to the sensor.

➡ Click `GO` to check if this step was successful.

➡ Click `STOP` when the channels have leveled out.

➡ Now click `GET`.

The detected `POWER` value is now displayed in the `POWER` function field. In dynamic mode, the `POWER` value is output to the numeric value display instead of the brightness value `INT` or `M`. The smaller the value, the brighter the color.

ⓘ The `INT` or `M` value should be < 900.

➡ Set `POWER MODE = STATIC`, and click `SEND`.

Step 4:

One `X` and one `Y` coordinate as well as intensity `INT` are calculated from the red, green, and blue data.

$$X = (R \cdot 4095) / (R + G + B)$$

$$Y = (G \cdot 4095) / (R + G + B)$$

$$INT = (R + G + B) / 3$$

➡ Click `GO` again to read the current data.

➡ Click `STOP` to end the data exchange.

➡ Select the `TEACH` tab to display the `TEACH` table.

➡ Select a row under `No. :` to which the currently present color is going to be taught.

ⓘ The sensor evaluates only rows marked in green. For teaching more than one color, select the number of teach-in colors under `MAXCOL-No. for PARA1`.

➡ Click `TEACH DATA TO`. The calculated values for `X`, `Y` and `INT` are transferred to the `TEACH` table and applied to the row that you selected under `No. :`

The graphic display shows a circle, which is the tolerance circle for this color. You can specify the radius for this circle under `TOL` (tolerance).

➡ To modify the `TOL` value, double-click the corresponding cell in the `TEACH` table.

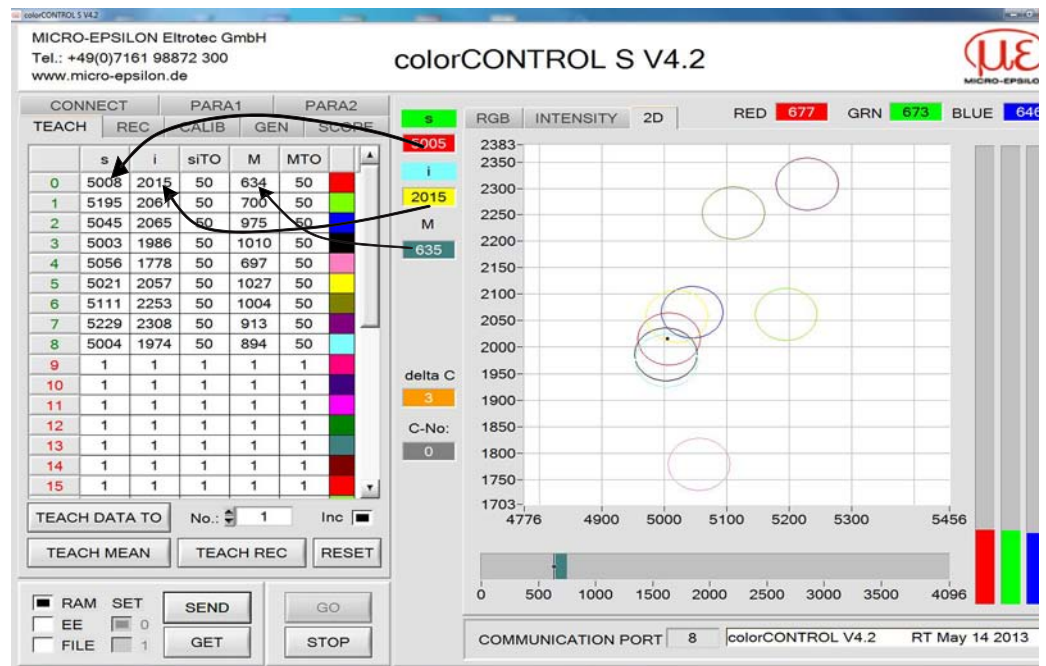
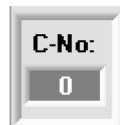

Fig. 66 Teaching colors in s i M - 2D mode

In 2D mode, the row below the graph shows the INT or M values for the color selected under No. : . The tolerance range is displayed in turquoise.

- Click SEND again to communicate the taught color to the sensor.
- Switch back to GO mode. When the sensor recognizes a row vector (color), the corresponding row number appears on the software interface under C-No: . A value of 255 means that none of the taught colors were recognized.



A color is only recognized if its current coordinates are within the tolerance circle.

Step 5:

- When teaching additional colors please make sure that the sensor is directed onto the respective color.
- Continue the teach-in procedure from step 4.

Step 6:

- After teaching all the channels, select EE (EEPROM) and click SEND to store the data in the non-volatile sensor memory.

A 2 Using TEMPCOMP-Scope Software

If a firmware update fails and temperature characteristics stored in the EE (EEPROM) are lost, these characteristics need to be re-created. This process requires a file with the appropriate data, which can be obtained from

MICRO-EPSILON Eltrotec GmbH at eltrotec@micro-epsilon.de

- Please include sensor type and serial number in your communications.
- Start temperature compensation by launching the TEMPCOMP-Scope software from the CD.

The software is located in the Support\Tools\Temperature Compensation directory.

Ensure that you have a functioning sensor connection. You might need to select a connection through CONNECT.

- If not done automatically, go to SELECT SENSOR to specify the correct sensor.

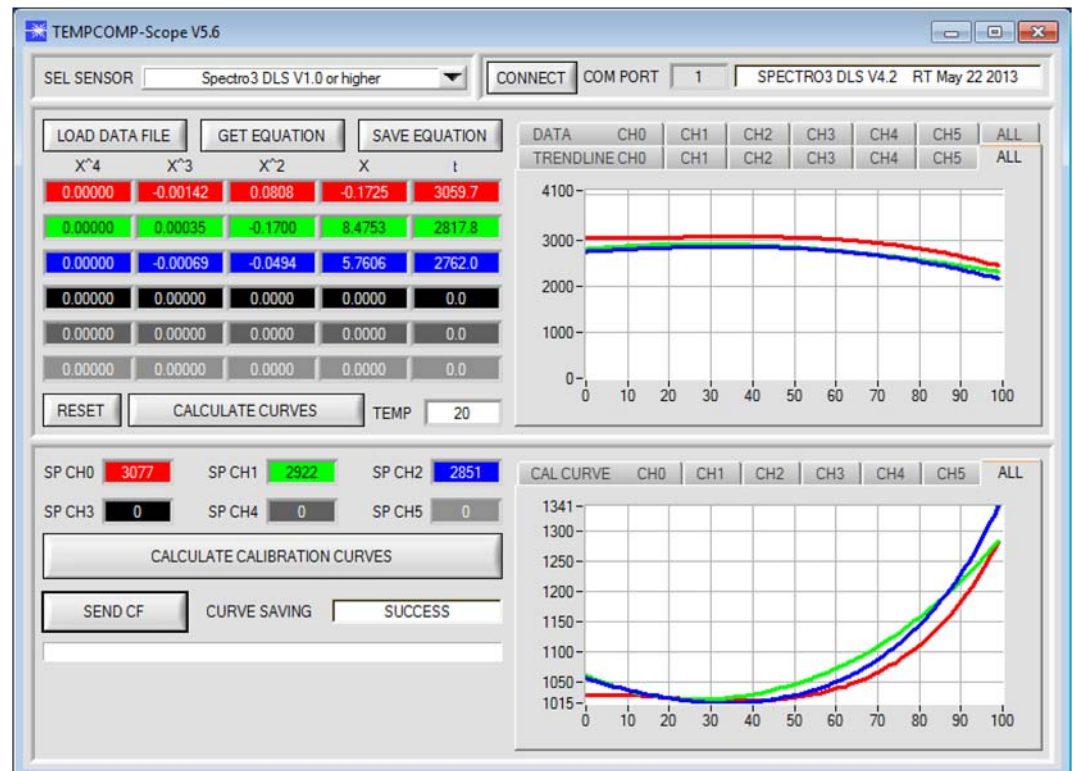

- Step 1:** ➤ Click GET EQUATION or LOAD DATA FILE to load the temperature compensation file obtained from MICRO-EPSILON Eltrotec GmbH.
- Step 2:** ➤ Click CALCULATE CURVES to display the data in the graph.
- Step 3:** ➤ Select the sensor's internal operating temperature (not in °C) which the sensor has at an ambient temperature of 20° (if not done automatically).
This value should be indicated in the file ID.
- Step 4:** ➤ Click CALCULATE CALIBRATION CURVES to calculate the line of best fit.
- Step 5:** ➤ Click SEND CF to save the line of best fit to the sensor's EE (EEPROM) memory.
- Step 6:** A SUCCESS message is displayed when the temperature compensation was successful.

i If you don't have a temperature compensation file,

- launch the TEMPCOMP-Scope software.
- Establish a connection, if none exists, and click SEND-CF.
The sensor will now operate as before but is not temperature-compensated.

A 3 External Triggering of colorSENSOR LT or OT

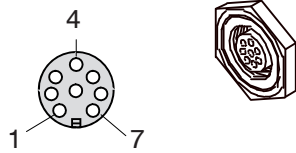

External triggering is performed through pin no. 3 (green) at the 8-pin socket of the colorSENSOR LT-3 or colorSENSOR OT-3 / PLC connection (CAB-M9-8P-St-ge; Xm-PUR; open).

TRIGGER:

➔ First, set the external trigger mode for colorSENSOR LT or colorSENSOR OT under PARA1.

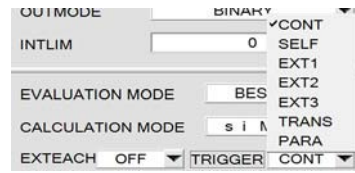
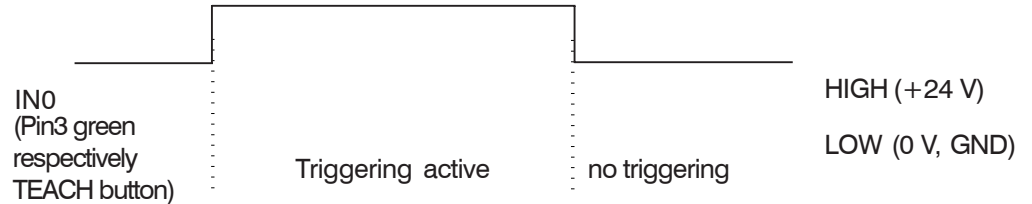

Fig. 67 PARA1 tab – TRIGGER options

➔ To do this, select EXT1, EXT2, EXT3, TRANS or PARA in the TRIGGER selection field, see Chap. 4.4.11 and following.

i The new setting is only activated at the sensor after you click SEND.

i The trigger input (IN0 PIN3 green at cable CAB-M9-8P-St-ge; Xm-PUR; open) is HIGH-active, i.e. a trigger event is detected provided IN0 = HIGH (+24 V).



A 4 LED Displays at the Color Sensors

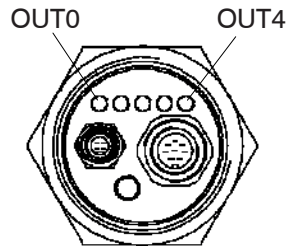

Fig. 68 colorSENSOR OT-3 as example

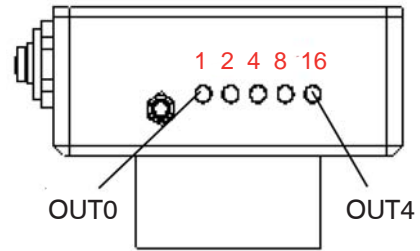

Fig. 69 Binary coding details for the output display using colorSENSOR LT-1-LC-20 as an example

A 4.1 Operating Modes

A 4.1.1 BINARY

5 yellow LEDs are used to visualize color coding at the housing of the color sensor. In BINARY mode (OUT BINARY), the color code indicated by the LEDs is simultaneously output as 5-bit binary data to the OUT0 ... OUT4 digital outputs of the 8-pin PLC socket, see Fig. 69. colorSENSOR LT-3 and colorSENSOR OT-3 can process a maximum of 31 colors (color codes 0 ... 30) based on the individual rows in the TEACH table. If an error occurs or a color is not recognized, all LEDs light up and the digital outputs OUT0 ... OUT4 are set to HIGH.

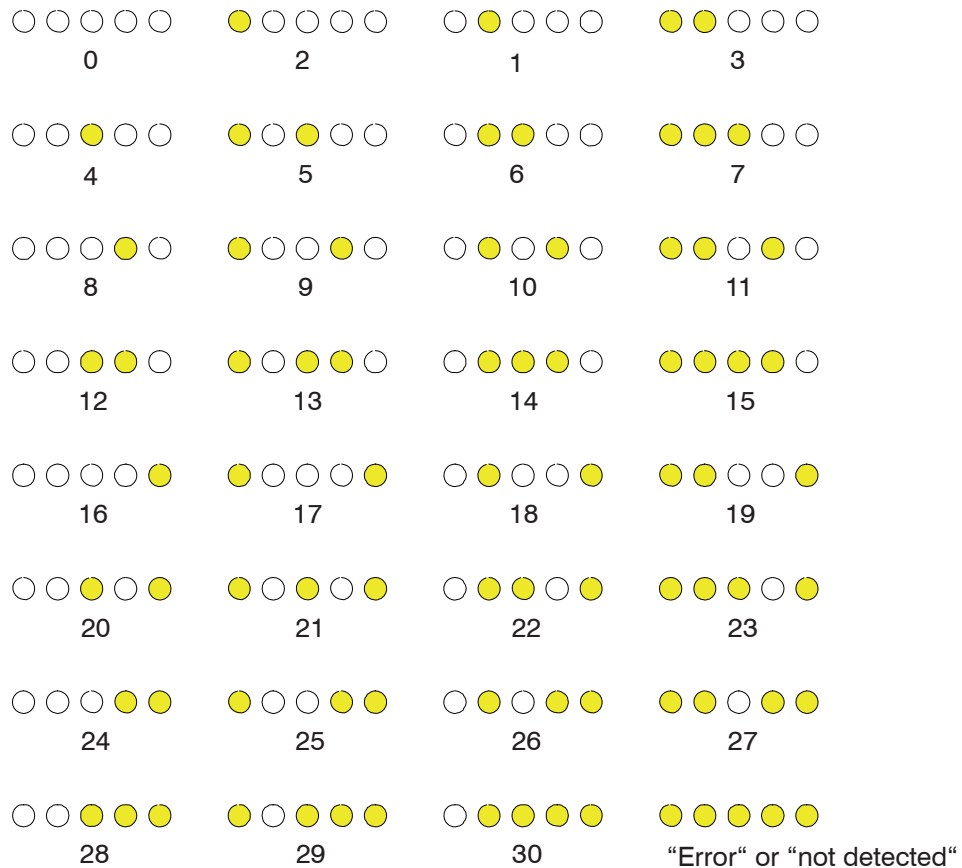

Fig. 70 BINARY mode / TEACH table allocation

A 4.1.2 DIRECT HI

DIRECT mode (OUT DIRECT HI or OUT DIRECT LO) allows for a maximum of 5 teach-in colors (numbers 0, 1, 2, 3, 4). If you selected DIRECT HI in the pull-down menu, see Chap. 4.4.7.2, the respective digital output will be set to HI, and the four other outputs are set to LO. If no color is detected, the digital outputs are set to LO (no LED is lit).

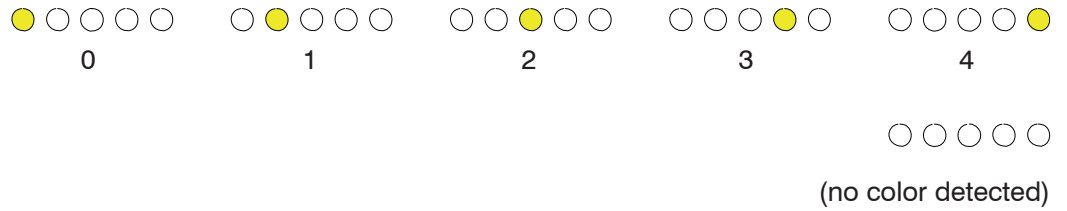

Fig. 71 DIRECT HI mode

A 4.1.3 DIRECT LO

If you selected DIRECT HI in the pull-down menu, see Chap. 4.4.7.2, the respective digital output will be set to LO, and the four other outputs are set to HI. If no color is detected, the digital outputs are set to HI (all LEDs are lit).

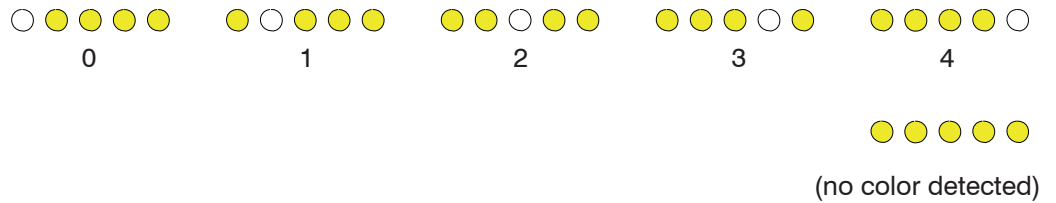

Fig. 72 DIRECT LO mode

A 5 Color Sensor Pin Assignments

A 5.1 Connecting colorSENSOR LT or colorSENSOR OT to a PC

Pin no.	Assignment	
1	24 VDC (+Ub)	
2	0 V (GND)	
3	Rx0	
4	Tx0	

Fig. 73 4-pin M5 connector (type Binder 707) colorSENSOR LT or colorSENSOR OT/PC-RS232

A 5.2 Connecting colorSENSOR LT or OT to a PLC

Pin no.	Color	Assignment	
1	white	0 V (GND)	
2	brown	+24 VDC ($\pm 10\%$)	
3	green	INO	
4	yellow	OUT0 (digital 0: type 0 ... 1V, digital 1: type +Ub - 10%)	
5	gray	OUT1 (digital 0: type 0 ... 1V, digital 1: type +Ub - 10%)	
6	pink	OUT2 (digital 0: type 0 ... 1V, digital 1: type +Ub - 10%)	
7	blue	OUT3 (digital 0: type 0 ... 1V, digital 1: type +Ub - 10%)	
8	red	OUT4 (digital 0: type 0 ... 1V, digital 1: type +Ub - 10%)	

Fig. 74 8-pin connector (type Binder 712) colorSENSOR LT or colorSENSOR OT for connection to a PLC

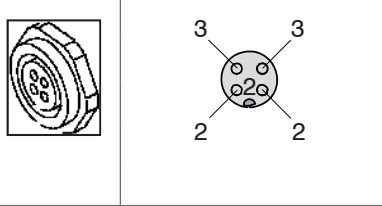
A 6 RS232 Communication Protocol

The sensors of the colorSENSOR LT or colorSENSOR OT series operate with the following parameters which are sent to the sensor or read from the sensor in the stated sequence.

• 2 bytes (8 bit) are one word (16 bit).

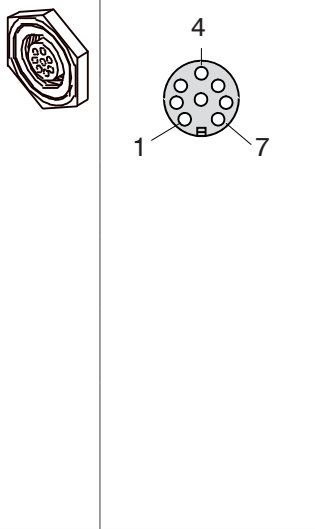
A 6.1 Parameters

	Parameters	Word	Meaning
Para1	POWER	Word	Transmitter intensity (0 ... 1000) Attention! Intensity in thousandth.
Para2	POWER MODE	Word	Transmitter mode: STATIC, DYNAMIC coded to (0, 1)
Para3	AVERAGE	Word	Signal averaging 1, 2, 4, 8, 16, 32, 64, 128, 256, 512, 1024, 2048, 4096, 8192, 16384 or 32768
Para4	EVALUATION MODE	Word	Evaluation mode: FIRST HIT, BEST HIT, MIN DIST, COL5, THD RGB coded to (0,1,2,3,4)
Para5	HOLD for C-No: 255	Word	Hold time for failure conditions (C-No: 255) coded to (0...100) [ms]
Para6	INTLIM	Word	Intensity limit (0 ... 4095)
Para7	MAXCOL-No.	Word	Number of colors (1,2,3,...,31)
Para8	OUTMODE	Word	Digital output function: direct/HI, binary, direct/LO coded to (0,1,2)
Para9	TRIGGER	Word	Trigger mode: CONT, SELF, EXT1, EXT2, EXT3, TRANS, PARA coded to (0, 1, 2, 3, 4, 5, 6)
Para10	EXTEACH	Word	External teach mode: OFF, ON, STAT1, DYN1 coded to (0,1,2,3)
Para11	CALCULA- TION MODE	Word	Calculation mode: "X Y INT - 2D", "s i M - 2D", "X Y INT - 3D", "s i M - 3D" coded to (0,1,2,3)
Para12	DYN WIN LO	Word	Lower limit for a dynamic window if POWER MODE=dynamic (0...4095)
Para13	DYN WIN HI	Word	Upper limit for a dynamic window if POWER MODE=dynamic (0...4095)
Para14	COLOR GROUPS	Word	Color groups enable: OFF, ON coded to (0,1)
Para15	LED MODE	Word	Control for the internal light source DC, AC, PULSE, OFF coded to (0,1,2,3)
Para16	GAIN	Word	Amplification of the integrated receiver AMP1, AMP2, AMP3, AMP4, AMP5, AMP6, AMP7, AMP8 coded to (1, 2, 3, 4, 5, 6, 7, 8)
Para17	INTEGRAL	Word	Signal integration (1... 250)

A 6.2 TEACH VECTOR

Each row in the **TEACH**, **GROUP** and **HOLD** tables determines a **TEACH VECTOR**.

The sensors of the colorSENSOR LT or colorSENSOR OT series use 31 **TEACH VECTORS** that are sent to the sensor or read from the sensor in one block in the stated sequence.

	TEACH VECTOR	Type	Meaning
TEACHVAL1	Teach Table Row 0 Column 0	Word	X / s of row 0
TEACHVAL2	Teach Table Row 0 Column 1	Word	Y / i of row 0
TEACHVAL3	Teach Table Row 0 Column 2	Word	CTO or INT / M of row 0
TEACHVAL4	Teach Table Row 0 Column 3	Word	INT / M or TOL of row 0
TEACHVAL5	Teach Table Row 0 Column 4	Word	ITO or free in row 0
TEACHVAL6	Group Table Row 0	Word	Group to which row 0 belongs if enabled
TEACHVAL7	Hold Table Row 0	Word	Hold time for row 0
TEACHVAL8	Free	Word	Send 0 as dummy
TEACHVAL9	Teach Table Row 1 Column 0	Word	X / s of row 1
TEACHVAL10	Teach Table Row 1 Column 1	Word	Y / i of row 1
TEACHVAL11	Teach Table Row 1 Column 2	Word	CTO or INT / M of row 1
...	
TEACHVAL248	Free	Word	Send as a dummy

The data acquired and processed by the sensor may also be sent by the sensor in the following sequence.

A 6.3 DATA VALUE

	DATA VALUE	Type	Meaning
DatVAL1	RED	Word	Calibrated and temperature compensated signal from channel red
DatVAL2	GREEN	Word	Calibrated and temperature compensated signal from channel green
DatVAL3	BLUE	Word	Calibrated and temperature compensated signal from channel blue
DatVAL4	X or s	Word	Calculated X or s value
DatVAL5	Y or i	Word	Calculated Y or s value
DatVAL6	INT or M	Word	Calculated INT or M value
DatVAL7	delta C	Word	Distance to a color hit
DatVAL8	C-No:	Word	Detected color
DatVAL9	GRP	Word	Detected group
DatVAL10	TRIG	Word	TRIG is 1 if a trigger condition was specified
DatVAL11	TEMP	Word	Temperature in the sensor (not in °C or °F)
DatVAL12	RAW RED	Word	Not calibrated and not temperature compensated signal from channel red
DatVAL13	RAW GREEN	Word	Not calibrated and not temperature compensated signal from channel green
DatVAL14	RAW BLUE	Word	Not calibrated and not temperature compensated signal from channel blue

Digital serial communication is used to exchange data between the software running on the PC and the sensor. For this purpose, the control unit has a EIA-232 compatible interface that uses the fixed parameters

- 8 data bits,
- 1 stop bit,
- no parity,
- no handshake.

Five values are available as baud rate: 9600 baud, 19200 baud, 38400 baud, 57600 baud and 115200 baud. As an option, PC software can also communicate through TCP/IP or USB. In these cases transparent interface converters must be used that allow a connection to the RS232 interface.

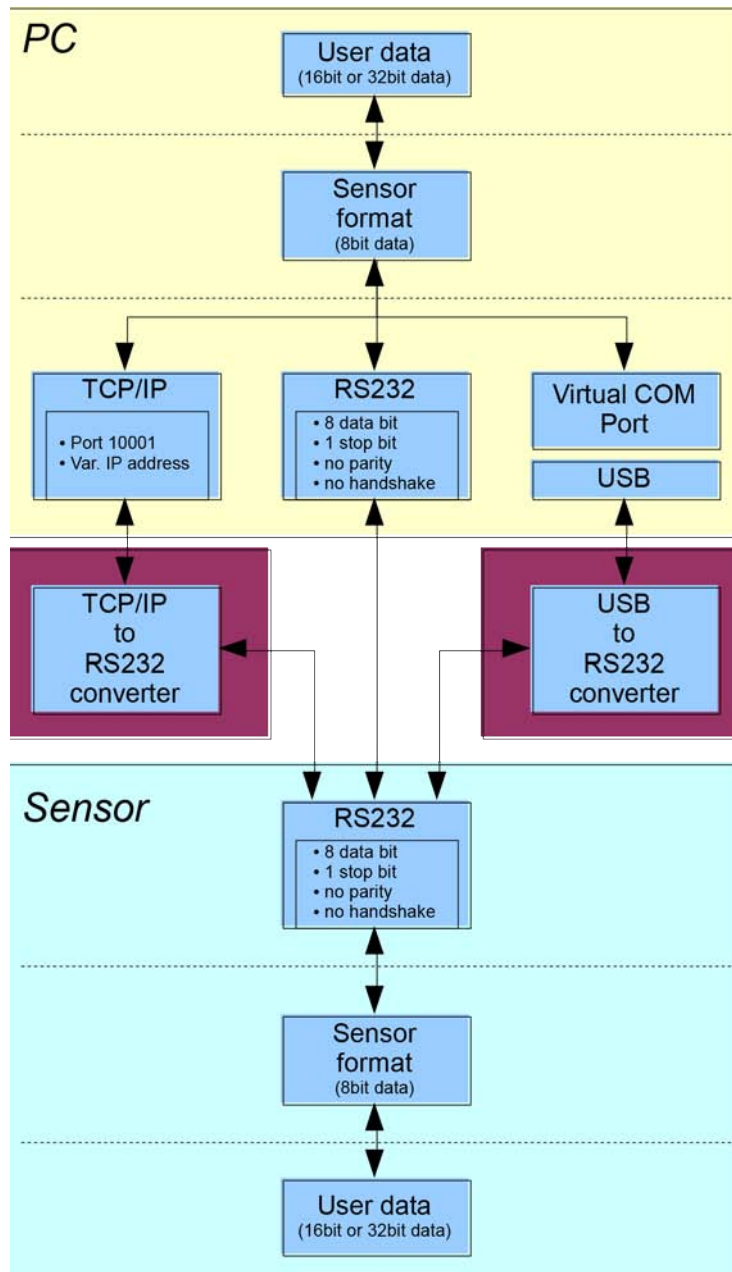

A proprietary protocol format that organizes and bundles the desired data is used for all physical connection variants between PC software and control unit. Depending on their type and function the actual data are 16- or 32-bit variables and represent integer or floating-point values. The protocol format consists of 8-bit wide unsigned words (“bytes”), which is why the actual data are distributed to several bytes at times.

The control unit is always passive (if no other behavior was specified), so the data exchange is always initiated by the PC software. The PC sends a data package (“frame”) that corresponds to the protocol format, either with or without appended data, and the control unit responds with a frame that matches the request.

The protocol format consists of two components:

a “header” and an optional appendix (“data”).

The header always has the same structure.

The first byte is a synchronization byte. It is always 85_{dec} (55_{hex}).

The second byte is called an instruction byte that determines what action is to be executed (e.g. send or store data).

A 16-bit value (argument) follows as the third and fourth byte. The argument is assigned a value based on its position.

The fifth and sixth byte again form a 16-bit value. This value states the number of appended data bytes. If no file is appended, these two bytes are 0_{dec} and 00_{hex} . The maximum number of bytes is 512.

The seventh byte contains the CRC8 checksum of all data bytes (data byte 0 up to and incl. data byte n).

The eighth byte is the CRC8 checksum for the header and is formed from bytes 0 up to and incl. byte 6.

The header always has a total length of 8 bytes. The entire frame may contain between 8 and 520 bytes.

Byte0 Header	Byte1 Header	Byte2 Header	Byte3 Header	Byte4 Header	Byte5 Header	Byte6 Header	Byte7 Header	Byte8 Data	Byte9 Data	...	Byte n+6 Data	Byte n+7 Data
0x55	<order>	<ARG> (lo byte)	<ARG> (hi byte)	<LEN> (lo byte)	<LEN> (hi byte)	CRC8 (Data)	CRC8 (Header)	Data1 (lo byte)	Data1 (hi byte)	...	Data n/2 (lo byte)	Data n/2 (hi byte)

The following sequences can be sent to the sensor:

Number	Sequence (header byte no. 2)	Example
0	Sensor answers with order=0 if a communication error occurs. ARG=1: Invalid order number was sent to the sensor. ARG=2: General communication error (incorrect baud rate, overflow, ...)	
1	Writes parameter to the sensor's RAM.	order = 1
2	Reads parameter from the sensor's RAM.	order = 2
3	Loads parameter and actual baud rate from the sensor's RAM to its EE (EEPROM).	order = 3
4	Loads parameter from the sensor's EE (EEPROM) to its RAM.	order = 4
5	Reads CONNECTION OK from sensor.	order = 5
6	Free	
7	Reads firmware string from the sensor.	order = 7
8	Reads data values from the sensor.	order = 8
30	Start and stop signal triggered sending of data frames.	order = 30
103	Starts white light correction and retrieves calibration factors, target value and maximum raw data difference.	order = 103
105	Retrieves cycle time from the sensor.	order = 105
190	Writes a new baud rate to the sensor.	order = 190

CRC8 checksum

A “cyclic redundancy check” (CRC) is used to verify data integrity. This algorithm makes it possible to detect individual bit errors, missing bytes, and faulty frames. A value (the checksum) is calculated from the data (bytes). This value is going to be checked and then transmitted together with the data package. The calculation uses a specified method which is based on a generator polynomial. The length of the checksum is 8 bit (= 1 byte). The generator polynomial is:

$$X^8 + X^5 + X^4 + X^0$$

Another CRC calculation is performed to verify the data after they have been received. If sent and newly calculated CRC values are identical, the data are deemed to be in order.

The following pseudo code can be used for checksum calculation:

```

calcCRC8 (data[ ], table[ ])
Input:    data[ ], n data of unsigned 8bit
            table [ ], 256 table entries of unsigned 8bit

Output:  crc8, unsigned 8bit
crc8 :      = AAhex
for I:    1 to n do
            idx := crc8 EXOR data [ i ]
            crc8 := table [ idx ]

endfor    crc8
return
    
```

0	94	188	226	97	63	221	131	194	156	126	32	163	253	31	65
157	195	33	127	252	162	64	30	95	1	227	189	62	96	130	220
35	125	159	193	66	28	254	160	225	191	93	3	128	222	60	98
190	224	2	92	223	129	99	61	124	34	192	158	29	67	161	255
70	24	250	164	39	121	155	197	132	218	56	102	229	187	89	7
219	133	103	57	186	228	6	88	25	71	165	251	120	38	196	154
101	59	217	135	4	90	184	230	167	249	27	69	198	152	122	36
248	166	68	26	153	199	37	123	58	100	134	216	91	5	231	185
140	210	48	110	237	179	81	15	78	16	242	172	47	113	147	205
17	79	173	243	112	46	204	146	211	141	111	49	178	236	14	80
175	241	19	77	206	144	114	44	109	51	209	143	12	82	176	238
50	108	142	208	83	13	239	177	240	174	76	18	145	207	45	115
202	148	118	40	171	245	23	73	8	86	180	234	105	55	213	139
87	9	235	181	54	104	138	212	149	203	41	119	244	170	72	22
233	183	85	11	136	214	52	106	43	117	151	201	74	20	246	168
116	42	200	150	21	75	169	247	182	232	10	84	215	137	107	53

Fig. 75 Table [checksum]

A 6.4 Examples

A 6.4.1 Write Parameters to the Sensor RAM

= sample order 1

<ARG> specifies whether to save parameters or teach vectors:

ARG = 0 ⇔ parameter set 0

ARG = 1 ⇔ parameter set 1

ARG = 2 ⇔ teach vector set 0

ARG = 3 ⇔ teach vector set 1

Data frame PC ⇔ sensor for parameter set 0

Byte0 Header	Byte1 Header	Byte2 Header	Byte3 Header	Byte4 Header	Byte5 Header	Byte6 Header	Byte7 Header	Byte8 Data	Byte9 Data	Byte10 Data	Byte11 Data
0x55	<order>	<ARG> (lo byte)	<ARG> (hi byte)	<LEN> (lo byte)	<LEN> (hi byte)	CRC8 (Data)	CRC8 (Header)	Para1 (lo byte)	Para1 (hi byte)	Para2 (lo byte)	Para2 (hi byte)
85 (dec)	1	0	0	34	0	162	249	244	1	0	0
		ARG=0		LEN=34				Para1=500		Para2=0	

Byte12 Data	Byte13 Data	Byte14 Data	Byte15 Data	Byte16 Data	Byte17 Data	Byte18 Data	Byte19 Data	Byte20 Data	Byte21 Data	Byte22 Data	Byte23 Data
Para3 (lo byte)	Para3 (hi byte)	Para4 (lo byte)	Para4 (hi byte)	Para5 (lo byte)	Para5 (hi byte)	Para6 (lo byte)	Para6 (hi byte)	Para7 (lo byte)	Para7 (hi byte)	Para8 (lo byte)	Para8 (hi byte)
1	0	1	0	10	0	0	0	5	0	0	0
Para3=1		Para4=1		Para5=10		Para6=0		Para7=5		Para8=0	

Byte24 Data	Byte25 Data	Byte26 Data	Byte27 Data	Byte28 Data	Byte29 Data	Byte30 Data	Byte31 Data	Byte32 Data	Byte33 Data	Byte34 Data	Byte35 Data
Para9 (lo byte)	Para9 (hi byte)	Para10 (lo byte)	Para10 (hi byte)	Para11 (lo byte)	Para11 (hi byte)	Para12 (lo byte)	Para12 (hi byte)	Para13 (lo byte)	Para13 (hi byte)	Para14 (lo byte)	Para14 (hi byte)
0	0	0	0	2	0	128	12	228	12	0	0
Para9=0		Para10=0		Para11=2		Para12=3200		Para13=3300		Para14=0	

Byte36 Data	Byte37 Data	Byte38 Data	Byte39 Data	Byte40 Data	Byte41 Data
Para15 (lo byte)	Para15 (hi byte)	Para16 (lo byte)	Para16 (hi byte)	Para17 (lo byte)	Para17 (hi byte)
1	0	8	0	1	0
Para15=1		Para16=8		Para17=1	

Data frame PC ⇔ sensor for TEACH vector set 0

Byte0 Header	Byte1 Header	Byte2 Header	Byte3 Header	Byte4 Header	Byte5 Header	Byte6 Header	Byte7 Header	Byte8 Data	Byte9 Data	Byte10 Data	Byte11 Data
0x55	<order>	<ARG> (lo byte)	<ARG> (hi byte)	<LEN> (lo byte)	<LEN> (hi byte)	CRC8 (Data)	CRC8 (Header)	Teach VAL1 (lo byte)	Teach VAL1 (hi byte)	Teach VAL2 (lo byte)	Teach VAL2 (hi byte)
85 (dec)	1	2	0	240	1	28	197	1	0	1	0
		ARG=0		LEN=496				TeachVal1=1		TeachVal2=1	

Byte12 Data	Byte13 Data	Byte14 Data	Byte15 Data	Byte16 Data	Byte17 Data	Byte18 Data	Byte19 Data	Byte20 Data	Byte21 Data	Byte22 Data	Byte23 Data
Teach VAL3 (lo byte)	Teach VAL3 (hi byte)	Teach VAL4 (lo byte)	Teach VAL4 (hi byte)	Teach VAL5 (lo byte)	Teach VAL5 (hi byte)	Teach VAL6 (lo byte)	Teach VAL6 (hi byte)	Teach VAL7 (lo byte)	Teach VAL7 (hi byte)	Teach VAL8 (lo byte)	Teach VAL8 (hi byte)
1	0	1	0	1	0	0	0	10	0	0	0
TeachVal3=1		TeachVal4=1		TeachVal5=1		TeachVal6=0		TeachVal7=10		TeachVal8=0	

Byte24 Data	Byte25 Data	Byte26 Data	Byte27 Data	Byte28 Data	Byte29 Data	Byte30 Data	Byte31 Data	Byte32 Data	Byte33 Data
Teach VAL9 (lo byte)	Teach VAL9 (hi byte)	Teach VAL10 (lo byte)	Teach VAL10 (hi byte)	Teach VAL11 (lo byte)	Teach VAL11 (hi byte)	Teach VAL12 (lo byte)	Teach VAL12 (hi byte)	Teach VAL13 (lo byte)	Teach VAL13 (hi byte)
1	0	1	0	1	0	1	0	1	0
Para9=1		Para10=0		Para11=1		Para12=1		Para13=1		...	

Data frame ⇔ PC

Byte0 Header	Byte1 Header	Byte2 Header	Byte3 Header	Byte4 Header	Byte5 Header	Byte6 Header	Byte7 Header
0x55	<order>	<ARG> (lo byte)	<ARG> (hi byte)	<LEN> (lo byte)	<LEN> (hi byte)	CRC8 (Data)	CRC8 (Header)
85 (dec)	1	0	0	0	0	170	224
ARG=0				LEN=0			

If you receive an argument greater than 0, the ARG parameters were out of range and are set to a default value.

A 6.4.2 Read Parameters from the Sensor RAM

= sample order 2

<ARG> determines whether to read a parameter or teach vectors:

ARG = 0 ⇔ parameter set 0

ARG = 1 ⇔ parameter set 1

ARG = 2 ⇔ teach vector set 0

ARG = 3 ⇔ teach vector set 1

Data frame PC ⇔ sensor

Byte0 Header	Byte1 Header	Byte2 Header	Byte3 Header	Byte4 Header	Byte5 Header	Byte6 Header	Byte7 Header
0x55	<order>	<ARG> (lo byte)	<ARG> (hi byte)	<LEN> (lo byte)	<LEN> (hi byte)	CRC8 (Data)	CRC8 (Header)
85 (dec)	2	0	0	0	0	170	185
ARG=0				LEN=0			

Data frame sensor ⇔ PC

Byte0 Header	Byte1 Header	Byte2 Header	Byte3 Header	Byte4 Header	Byte5 Header	Byte6 Header	Byte7 Header	Byte8 Data	Byte9 Data	Byte10 Data	Byte11 Data
0x55	<order>	<ARG> (lo byte)	<ARG> (hi byte)	<LEN> (lo byte)	<LEN> (hi byte)	CRC8 (Data)	CRC8 (Header)	Para1 (lo byte)	Para1 (hi byte)	Para2 (lo byte)	Para2 (hi byte)
85 (dec)	2	0	0	34	0	162	160	244	1	0	0
ARG=0				LEN=34				Para1=500		Para2=0	

Byte12 Data	Byte13 Data	Byte14 Data	Byte15 Data	Byte16 Data	Byte17 Data	Byte18 Data	Byte19 Data	Byte20 Data	Byte21 Data	Byte22 Data	Byte23 Data
Para3 (lo byte)	Para3 (hi byte)	Para4 (lo byte)	Para4 (hi byte)	Para5 (lo byte)	Para5 (hi byte)	Para6 (lo byte)	Para6 (hi byte)	Para7 (lo byte)	Para7 (hi byte)	Para8 (lo byte)	Para8 (hi byte)
1	0	1	0	10	0	0	0	5	0	0	0
Para3=1		Para4=1		Para5=10		Para6=0		Para7=5		Para8=0	

Byte24 Data	Byte25 Data	Byte26 Data	Byte27 Data	Byte28 Data	Byte29 Data	Byte30 Data	Byte31 Data	Byte32 Data	Byte33 Data	Byte34 Data	Byte35 Data
Para9 (lo byte)	Para9 (hi byte)	Para10 (lo byte)	Para10 (hi byte)	Para11 (lo byte)	Para11 (hi byte)	Para12 (lo byte)	Para12 (hi byte)	Para13 (lo byte)	Para13 (hi byte)	Para14 (lo byte)	Para14 (hi byte)
0	0	0	0	2	0	128	12	228	12	0	0
Para9=0		Para10=0		Para11=2		Para12=3200		Para13=3300		Para14=0	

Byte36 Data	Byte37 Data	Byte38 Data	Byte39 Data	Byte40 Data	Byte41 Data
Para15 (lo byte)	Para15 (hi byte)	Para16 (lo byte)	Para16 (hi byte)	Para17 (lo byte)	Para17 (hi byte)
1	0	8	0	1	0
Para15=1		Para16=8		Para17=1	

A 6.4.3 Load Parameters and Current Baud Rate from the Sensor RAM to its EEPROM

= sample order 3

Data frame PC ↔ sensor

Byte0 Header	Byte1 Header	Byte2 Header	Byte3 Header	Byte4 Header	Byte5 Header	Byte6 Header	Byte7 Header	
0x55	<order>	<ARG> (lo byte)	<ARG> (hi byte)	<LEN> (lo byte)	<LEN> (hi byte)	CRC8 (Data)	CRC8 (Header)	
85 (dec)	3	0	0	0	0	170	142	
ARG=0			LEN=0					

Data frame sensor ↔ PC

Byte0 Header	Byte1 Header	Byte2 Header	Byte3 Header	Byte4 Header	Byte5 Header	Byte6 Header	Byte7 Header	
0x55	<order>	<ARG> (lo byte)	<ARG> (hi byte)	<LEN> (lo byte)	<LEN> (hi byte)	CRC8 (Data)	CRC8 (Header)	
85 (dec)	3	0	0	0	0	170	142	
ARG=0			LEN=0					

A 6.4.4 Load Parameters from the Sensor EEPROM to its RAM

= sample order 4

Data frame PC ↔ sensor

Byte0 Header	Byte1 Header	Byte2 Header	Byte3 Header	Byte4 Header	Byte5 Header	Byte6 Header	Byte7 Header	
0x55	<order>	<ARG> (lo byte)	<ARG> (hi byte)	<LEN> (lo byte)	<LEN> (hi byte)	CRC8 (Data)	CRC8 (Header)	
85 (dec)	4	0	0	0	0	170	11	
ARG=0			LEN=0					

Data frame sensor ↔ PC

Byte0 Header	Byte1 Header	Byte2 Header	Byte3 Header	Byte4 Header	Byte5 Header	Byte6 Header	Byte7 Header	
0x55	<order>	<ARG> (lo byte)	<ARG> (hi byte)	<LEN> (lo byte)	<LEN> (hi byte)	CRC8 (Data)	CRC8 (Header)	
85 (dec)	4	0	0	0	0	170	11	
ARG=0			LEN=0					

A 6.4.5 Read Connection OK from the Sensor

= sample order 5

Data frame PC ↔ sensor

Byte0 Header	Byte1 Header	Byte2 Header	Byte3 Header	Byte4 Header	Byte5 Header	Byte6 Header	Byte7 Header	
0x55	<order>	<ARG> (lo byte)	<ARG> (hi byte)	<LEN> (lo byte)	<LEN> (hi byte)	CRC8 (Data)	CRC8 (Header)	
85 (dec)	5	0	0	0	0	170	60	
ARG=0			LEN=0					

Data frame sensor ↔ PC

Byte0 Header	Byte1 Header	Byte2 Header	Byte3 Header	Byte4 Header	Byte5 Header	Byte6 Header	Byte7 Header	
0x55	<order>	<ARG> (lo byte)	<ARG> (hi byte)	<LEN> (lo byte)	<LEN> (hi byte)	CRC8 (Data)	CRC8 (Header)	
85 (dec)	5	170	0	0	0	170	178	
ARG=170			LEN=0					

A 6.4.6 Read Firmware Sequence from the Sensor

= sample order 7

Data frame PC ⇨ sensor

Byte0 Header	Byte1 Header	Byte2 Header	Byte3 Header	Byte4 Header	Byte5 Header	Byte6 Header	Byte7 Header
0x55	<order>	<ARG> (lo byte)	<ARG> (hi byte)	<LEN> (lo byte)	<LEN> (hi byte)	CRC8 (Data)	CRC8 (Header)
85 (dec)	7	0	0	0	0	170	82
ARG=0				LEN=0			

Data frame sensor ⇨ PC

Byte0 Header	Byte1 Header	Byte2 Header	Byte3 Header	Byte4 Header	Byte5 Header	Byte6 Header	Byte7 Header	Byte8 Data	Byte9 Data	Byte10 Data	Byte11 Data
0x55	<order>	<ARG> (lo byte)	<ARG> (hi byte)	<LEN> (lo byte)	<LEN> (hi byte)	CRC8 (Data)	CRC8 (Header)	ASCII	ASCII	ASCII	ASCII
85 (dec)	7	0	0	72	0	183	38	F	I	R	M
ARG=0				LEN=72							

Byte12 Data	Byte13 Data	Byte14 Data	Byte15 Data	Byte16 Data	Byte17 Data	Byte18 Data	Byte19 Data	Byte20 Data	Byte21 Data	Byte22 Data	Byte23 Data
ASCII	ASCII	ASCII	ASCII	ASCII	ASCII	ASCII	ASCII	ASCII	ASCII	ASCII	ASCII
W	A	R	E		S	T	R	I	N	G	

Byte24 Data	Byte25 Data	Byte26 Data	Byte27 Data	Byte28 Data	Byte29 Data	Byte30 Data	Byte31 Data	Byte32 Data	Byte33 Data	Byte34 Data	Byte35 Data
ASCII	ASCII	ASCII	ASCII	ASCII	ASCII	ASCII	ASCII	ASCII	ASCII	ASCII	ASCII
										...	R

Byte36 Data	Byte37 Data	Byte38 Data	Byte39 Data	Byte40 Data	Byte41 Data	Byte42 Data	Byte43 Data	Byte44 Data	Byte45 Data	Byte46 Data	Byte47 Data
ASCII	ASCII	ASCII	ASCII	ASCII	ASCII	ASCII	ASCII	ASCII	ASCII	ASCII	ASCII
T	:	K	W	x	x	/	x	x			

Byte48 Data	Byte49 Data	Byte50 Data	Byte51 Data	Byte52 Data	Byte53 Data	Byte54 Data	Byte55 Data	Byte56 Data	Byte57 Data	Byte58 Data	Byte59 Data
ASCII	ASCII	ASCII	ASCII	ASCII	ASCII	ASCII	ASCII	ASCII	ASCII	ASCII	ASCII

Byte60 Data	Byte61 Data	Byte62 Data	Byte63 Data	Byte64 Data	Byte65 Data	Byte66 Data	Byte67 Data	Byte68 Data	Byte69 Data	Byte70 Data	Byte71 Data
ASCII	ASCII	ASCII	ASCII	ASCII	ASCII	ASCII	ASCII	ASCII	ASCII	ASCII	ASCII

Byte72 Data	Byte73 Data	Byte74 Data	Byte75 Data	Byte76 Data	Byte77 Data	Byte78 Data	Byte79 Data	Byte80 Data	Byte81 Data
ASCII	ASCII	ASCII	ASCII	ASCII	ASCII	ASCII	ASCII	ASCII	ASCII

A 6.4.7 Read Data Values from the Sensor

= sample order 8

Data frame PC ⇔ sensor

Byte0 Header	Byte1 Header	Byte2 Header	Byte3 Header	Byte4 Header	Byte5 Header	Byte6 Header	Byte7 Header
0x55	<order>	<ARG> (lo byte)	<ARG> (hi byte)	<LEN> (lo byte)	<LEN> (hi byte)	CRC8 (Data)	CRC8 (Header)
85 (dec)	8	0	0	0	0	170	118
ARG=0			LEN=0				

Data frame sensor ⇔ PC

Byte0 Header	Byte1 Header	Byte2 Header	Byte3 Header	Byte4 Header	Byte5 Header	Byte6 Header	Byte7 Header	Byte8 Data	Byte9 Data	Byte10 Data	Byte11 Data
0x55	<order>	<ARG> (lo byte)	<ARG> (hi byte)	<LEN> (lo byte)	<LEN> (hi byte)	CRC8 (Data)	CRC8 (Header)	DatVAL1 (lo byte)	DatVAL1 (hi byte)	DatVAL2 (lo byte)	DatVAL2 (hi byte)
85 (dec)	8	0	0	28	0	166	36	115	10	55	6
ARG=0			LEN=28					DatVAL=2675		DatVAL=1591	

Byte12 Data	Byte13 Data	Byte14 Data	Byte15 Data	Byte16 Data	Byte17 Data	Byte18 Data	Byte19 Data	Byte20 Data	Byte21 Data	Byte22 Data	Byte23 Data
DatVAL3 (lo byte)	DatVAL3 (hi byte)	DatVAL4 (lo byte)	DatVAL4 (hi byte)	DatVAL5 (lo byte)	DatVAL5 (hi byte)	DatVAL6 (lo byte)	DatVAL6 (hi byte)	DatVAL7 (lo byte)	DatVAL7 (hi byte)	DatVAL8 (lo byte)	DatVAL8 (hi byte)
175	4	212	7	168	4	29	7	255	255	255	0
DatVal3=1199		DatVal4=2004		DatVal5=1192		DatVal6=1821		DatVal7=65534		DatVal8=255	

Byte24 Data	Byte25 Data	Byte26 Data	Byte27 Data	Byte28 Data	Byte29 Data	Byte30 Data	Byte31 Data	Byte32 Data	Byte33 Data	Byte34 Data	Byte35 Data
DatVAL9 (lo byte)	DatVAL9 (hi byte)	DatVAL10 (lo byte)	DatVAL10 (hi byte)	DatVAL11 (lo byte)	DatVAL11 (hi byte)	DatVAL12 (lo byte)	DatVAL12 (hi byte)	DatVAL13 (lo byte)	DatVAL13 (hi byte)	DatVAL14 (lo byte)	DatVAL14 (hi byte)
255	0	0	0	20	0	115	10	55	6	175	4
DatVal9=255		DatVal10=0		DatVal11=20		DatVal12=2675		DatVal13=1591		DatVal14=1199	

A 6.4.8 Start and Stop Triggered Sending of Data Frame Values from the Sensor

= sample order 30

Start triggered sending of data frames

Data frame PC ⇔ sensor

Byte0 Header	Byte1 Header	Byte2 Header	Byte3 Header	Byte4 Header	Byte5 Header	Byte6 Header	Byte7 Header
0x55	<order>	<ARG> (lo byte)	<ARG> (hi byte)	<LEN> (lo byte)	<LEN> (hi byte)	CRC8 (Data)	CRC8 (Header)
85 (dec)	30	1	0	0	0	170	82
ARG=1			LEN=0				

Data frame sensor ⇔ PC

Byte0 Header	Byte1 Header	Byte2 Header	Byte3 Header	Byte4 Header	Byte5 Header	Byte6 Header	Byte7 Header
0x55	<order>	<ARG> (lo byte)	<ARG> (hi byte)	<LEN> (lo byte)	<LEN> (hi byte)	CRC8 (Data)	CRC8 (Header)
85 (dec)	30	1	0	0	0	170	82
ARG=1			LEN=0				

Stop triggered sending of data frames

Data frame PC ⇔ sensor

Byte0 Header	Byte1 Header	Byte2 Header	Byte3 Header	Byte4 Header	Byte5 Header	Byte6 Header	Byte7 Header
0x55	<order>	<ARG> (lo byte)	<ARG> (hi byte)	<LEN> (lo byte)	<LEN> (hi byte)	CRC8 (Data)	CRC8 (Header)
85 (dec)	30	0	0	0	0	170	159
ARG=0			LEN=0				

Data frame sensor ⇨ PC

Byte0 Header	Byte1 Header	Byte2 Header	Byte3 Header	Byte4 Header	Byte5 Header	Byte6 Header	Byte7 Header
0x55	<order>	<ARG> (lo byte)	<ARG> (hi byte)	<LEN> (lo byte)	<LEN> (hi byte)	CRC8 (Data)	CRC8 (Header)
85 (dec)	30	0	0	0	0	170	159
ARG=0				LEN=0			

A 6.4.9 Start White Light Correction and Obtain Calibration Factors, Set Value and Max Delta of Raw Data

= sample order 103

Data frame PC ⇨ sensor

Byte0 Header	Byte1 Header	Byte2 Header	Byte3 Header	Byte4 Header	Byte5 Header	Byte6 Header	Byte7 Header
0x55	<order>	<ARG> (lo byte)	<ARG> (hi byte)	<LEN> (lo byte)	<LEN> (hi byte)	CRC8 (Data)	CRC8 (Header)
85 (dec)	103	0	0	0	0	170	145
ARG=0				LEN=0			

Data frame sensor ⇨ PC

Byte0 Header	Byte1 Header	Byte2 Header	Byte3 Header	Byte4 Header	Byte5 Header	Byte6 Header	Byte7 Header	Byte8 Data	Byte9 Data	Byte10 Data	Byte11 Data
0x55	<order>	<ARG> (lo byte)	<ARG> (hi byte)	<LEN> (lo byte)	<LEN> (hi byte)	CRC8 (Data)	CRC8 (Header)	CF RED (lo byte)	CF RED (hi byte)	CF GREEN (lo byte)	CF GREEN (hi byte)
85 (dec)	103	0	0	10	0	212	28	228	3	223	3
ARG=0				LEN=28				CF_RED=996		CF_GREEN=991	

Byte12 Data	Byte13 Data	Byte14 Data	Byte15 Data	Byte16 Data	Byte17 Data
CF BLUE (lo byte)	CF BLUE (hi byte)	SET VALUE (lo byte)	SET VALUE (hi byte)	MAX DELTA (lo byte)	MAX DELTA (hi byte)
65	4	134	12	43	1
CF_BLUE=1089		SETVALUE=3206		MAX DELTA=299	

A 6.4.10 Obtain Cycle Time from the Sensor

= sample order 105

Data frame PC ⇨ sensor

Byte0 Header	Byte1 Header	Byte2 Header	Byte3 Header	Byte4 Header	Byte5 Header	Byte6 Header	Byte7 Header
0x55	<order>	<ARG> (lo byte)	<ARG> (hi byte)	<LEN> (lo byte)	<LEN> (hi byte)	CRC8 (Data)	CRC8 (Header)
85 (dec)	105	0	0	0	0	170	130
ARG=0				LEN=0			

Data frame sensor ⇨ PC

Byte0 Header	Byte1 Header	Byte2 Header	Byte3 Header	Byte4 Header	Byte5 Header	Byte6 Header	Byte7 Header	Byte8 Data	Byte9 Data	Byte10 Data	Byte11 Data
0x55	<order>	<ARG> (lo byte)	<ARG> (hi byte)	<LEN> (lo byte)	<LEN> (hi byte)	CRC8 (Data)	CRC8 (Header)	lo word lo byte	lo word hi byte	hi word lo byte	hi word hi byte
85 (dec)	105	0	0	8	0	206	163	40	28	2	0
ARG=0				LEN=8				CYCLE COUNT=138280			

Byte12 Data	Byte13 Data	Byte14 Data	Byte15 Data
lo word lo byte	lo word hi byte	hi word lo byte	hi word hi byte
144	1	0	0
COUNTER TIME=400			

$$\text{Cycle Time [Hz]} = \text{CYCLE COUNT} / (\text{COUNTER TIME} * 0.01)$$

$$\text{Cycle Time [ms]} = (\text{COUNTER TIME} * 0.01) / \text{CYCLE COUNT}$$

A 6.4.11 Send New Baud Rate to the Sensor

= sample order 190

Data frame PC ⇄ sensor

Byte0 Header	Byte1 Header	Byte2 Header	Byte3 Header	Byte4 Header	Byte5 Header	Byte6 Header	Byte7 Header
0x55	<order>	<ARG> (lo byte)	<ARG> (hi byte)	<LEN> (lo byte)	<LEN> (hi byte)	CRC8 (Data)	CRC8 (Header)
85 (dec)	190	1	0	0	0	170	14
ARG=1			LEN=0				

The argument determines the new baud rate:

ARG=0: baud rate = 9600

ARG=1: baud rate = 19200

ARG=2: baud rate = 38400

ARG=3: baud rate = 57600

ARG=4: baud rate = 115200

Data frame sensor ⇄ PC

Byte0 Header	Byte1 Header	Byte2 Header	Byte3 Header	Byte4 Header	Byte5 Header	Byte6 Header	Byte7 Header
0x55	<order>	<ARG> (lo byte)	<ARG> (hi byte)	<LEN> (lo byte)	<LEN> (hi byte)	CRC8 (Data)	CRC8 (Header)
85 (dec)	190	0	0	0	0	170	195
ARG=0			LEN=0				



MICRO-EPSILON Eltrotec GmbH
Heinkelstraße 2 · 73066 UHINGEN / Germany
Tel. +49 (0) 7161 / 98872-300 · Fax +49 (0) 7161 / 98872-303
eltrotec@micro-epsilon.de · www.micro-epsilon.com

X9751279-A021054HDR

