



More Precision.

induSENSOR

Linear inductive displacement sensors



LDR series - linear displacement sensors



No wear and no maintenance
Excellent temperature stability
Operating temperature range up to 160°C
Compact design - short installed length
Small sensor diameter
High measurement signal quality

The specific sensor configuration of the linear displacement sensors in the LDR series is characterised by a short, compact design with small diameter. Three connections are required as an interface to the sensor. The compact design and the small sensor diameter facilitate the installation of the measurement systems in locations where space is restricted.

Fields of use and applications

The inexpensive LDR sensors are also particularly suitable for large-scale installation under restricted spatial conditions and in industrial environments with a high measuring rate.

Model	LDR-10-		LDR-25-		LDR-50-	
Connection	SA	CA	SA	CA	SA	CA
Measuring range	10mm		25mm		50mm	
Measuring principle	LDR - sensor					
Linearity	typ. $\pm 0.30\%$ FSO $\pm 0.030\text{mm}$		typ. $\pm 0.35\%$ FSO $\pm 0.088\text{mm}$ max. $\pm 0.50\%$ FSO		typ. $\pm 0.7\%$ FSO $\pm 0.35\text{mm}$	
Excitation frequency	16kHz		12kHz		8kHz	
Excitation amplitude	$1V_{\text{eff}}$		$1V_{\text{eff}}$		$2.6V_{\text{eff}}$	
Sensitivity	51mV/Vmm		21mV/Vmm		5.5mV/Vmm	
Temperature range	SA	storage: $-40^{\circ}\text{C} \dots +80^{\circ}\text{C}$ / operation: $-15^{\circ}\text{C} \dots +80^{\circ}\text{C}$				
	CA	storage: $-40^{\circ}\text{C} \dots +160^{\circ}\text{C}$ / operation: $-40^{\circ}\text{C} \dots +160^{\circ}\text{C}$				
Temperature stability	zero	$\pm 30\text{ppm} / ^{\circ}\text{C}$				$\pm 40\text{ppm} / ^{\circ}\text{C}$
	sensitivity	$\pm 100\text{ppm} / ^{\circ}\text{C}$				$\pm 150\text{ppm} / ^{\circ}\text{C}$
Housing (material)	ferromagnetic stainless steel					
Weight sensor (without plunger)	9g	24g	14g	28g	23g	37g
Weight plunger	1.5g		2.2g		3.5g	
Sensor cable - minimum bending radius fixed / moved	8 / 15mm	10 / 30mm	8 / 15mm	10 / 30mm	8 / 15mm	10 / 30mm
Outer cable diameter	3.1mm	1.8mm	3.1mm	1.8mm	3.1mm	1.8mm
Protection class	IP 67					
Shock	40g, 3000 shocks / axis 100g radial, 300g axial					
Vibration	5Hz ... 44Hz $\pm 2.5\text{mm}$ / 44Hz ... 500Hz $\pm 20\text{g}$					
Electric connection	SA	3-pin connector (accessory cable, article 0157047/047, 3 or 5m)				
	CA	integral axial cable (shielded), 2m				
Electronics	MSC7210 (page 12 - 13)					

F50 = Full Scale Output SA = connector axial CA = cable axial

LDR-x-SA

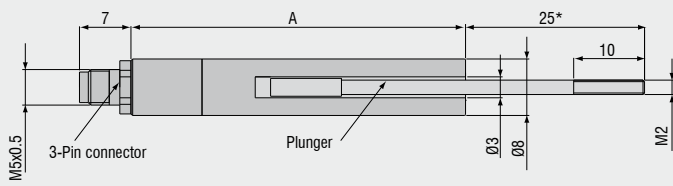

* Plunger at start of measuring range

Model	A
LDR-10-SA	47mm
LDR-25-SA	73mm
LDR-50-SA	127mm

LDR-x-CA

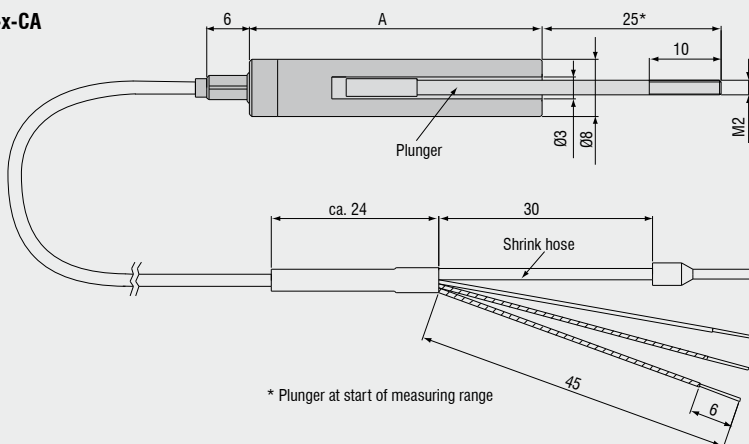

* Plunger at start of measuring range

Model	A
LDR-10-CA	41mm
LDR-25-CA	67mm
LDR-50-CA	121mm

MSC7210 Sensor controller for LDR series



- Rugged die-cast housing**
- For all sensors in the LDR series**
- Adjustable excitation frequency**
4 ... 33kHz
- Zero point and gain can be adjusted**
- High resolution and linearity**

The MSC7210 is a single-channel electronic unit for the operation of inductive displacement transducers according to the LDR principle. The zero point and gain can be set over a wide range using trimming potentiometers. Due to the small size, the electronic unit is versatile in mounting.

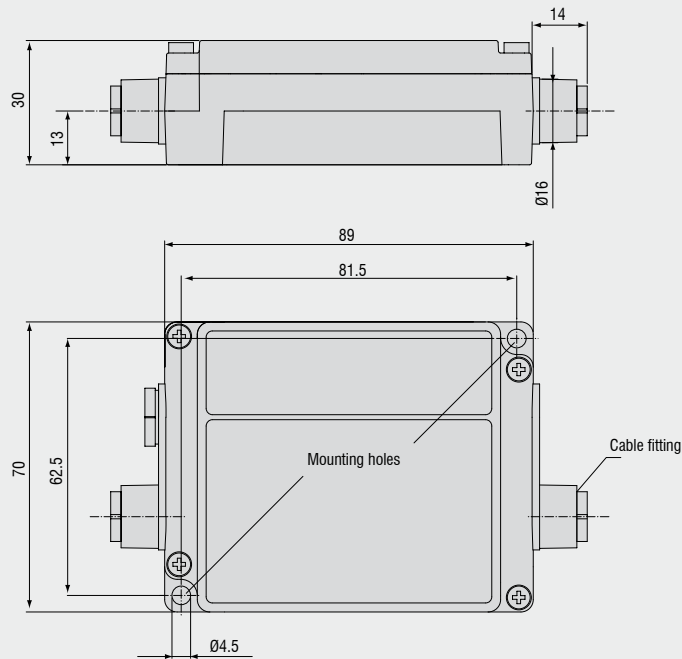

Model	MSC7210-U	MSC7210-I
Power supply	18 ... 30VDC	
Protection	polarity reversal and overvoltage protection	
Sensor principle	LDR sensor	
Sensor excitation	1000 ... 2600mV 4 bis 33kHz (16 steps selectable via DIPswitch)	
Range	gain zero	-20 ... +270% FSO (trimpot) ±70% FSO (trimpot)
Output signal	2 ... 10VDC	4 ... 20mA
Noise	< 1.5mV _{eff} * < 15mV _{ss}	< 3μA _{eff} * < 30 μA _{ss}
Linearity	< ± 0.02% FSO	
Frequency response	300Hz	
Temperature range	storage operating	-40°C ... +85°C 0°C ... +70°C
Temperature stability	±100ppm / °C	
Housing material	zinc die cast	
Electromagnetic compatibility (EMC)	EN 61326-1:2006 (spurious emission) EN 61326-2-3:2006 (immunity to interference)	
Protection class	IP 65	
Shock	test signal: half sine wave peak acceleration 15g shock duration 6ms test axes x, y, z No. of impacts per axis: 1000	
Vibration	test signal: sine - sweep frequency: 20 ... 500Hz test axes x, y, z No. of frequency cycles per axis: 10	
Sensor connection	plugable screw clamp 4-pin	
Signal/supply connection	plugable screw clamp 5-pin	

FSO = Full Scale Output

* RMS AC measurement, frequency 3Hz ... 300Hz

High performance sensors made by Micro-Epsilon



Sensors and systems for displacement and position



Sensors and measurement devices for non-contact temperature measurement

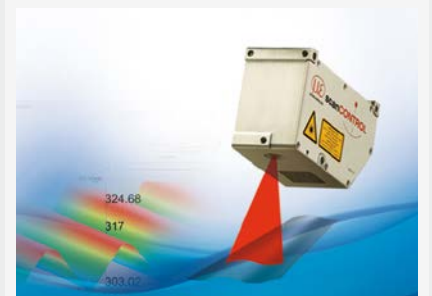

2D/3D profile sensors (laser scanner)

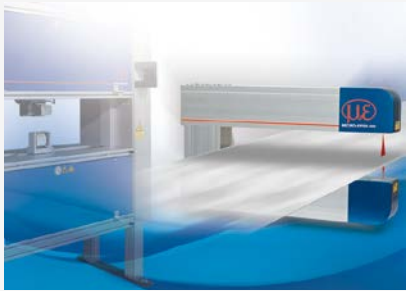

Measurement and inspection systems for quality assurance



Optical micrometers, fibre optic sensors and fiber optics



Colour recognition sensors, LED analyzers and colour online spectrometer