



# More Precision

## wire**SENSOR**

Draw-wire displacement sensors





- Robust plastic housing
- Customized versions for OEM
- Wire potentiometer

Model MK77 Output P25

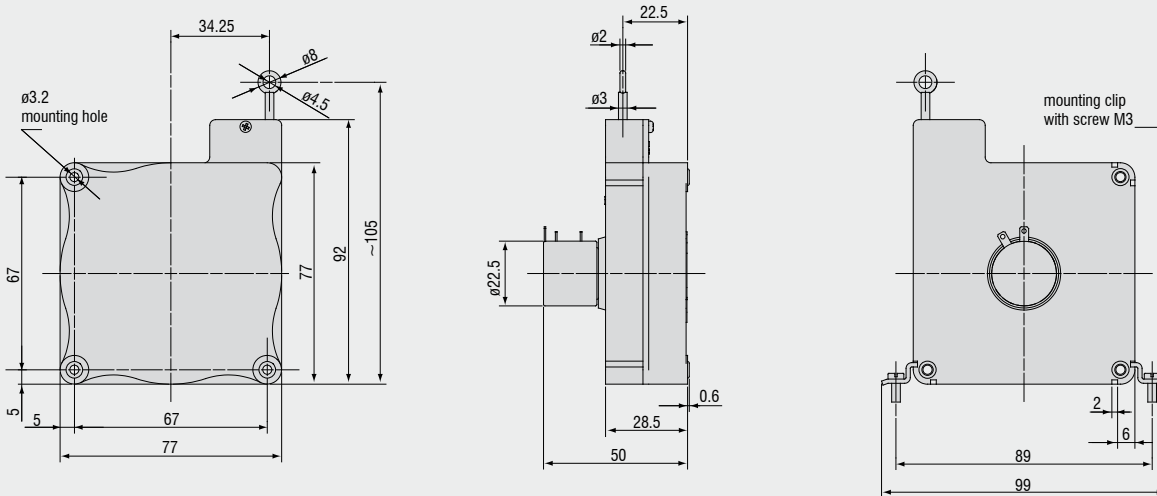

Model MK77 Output CR-P25

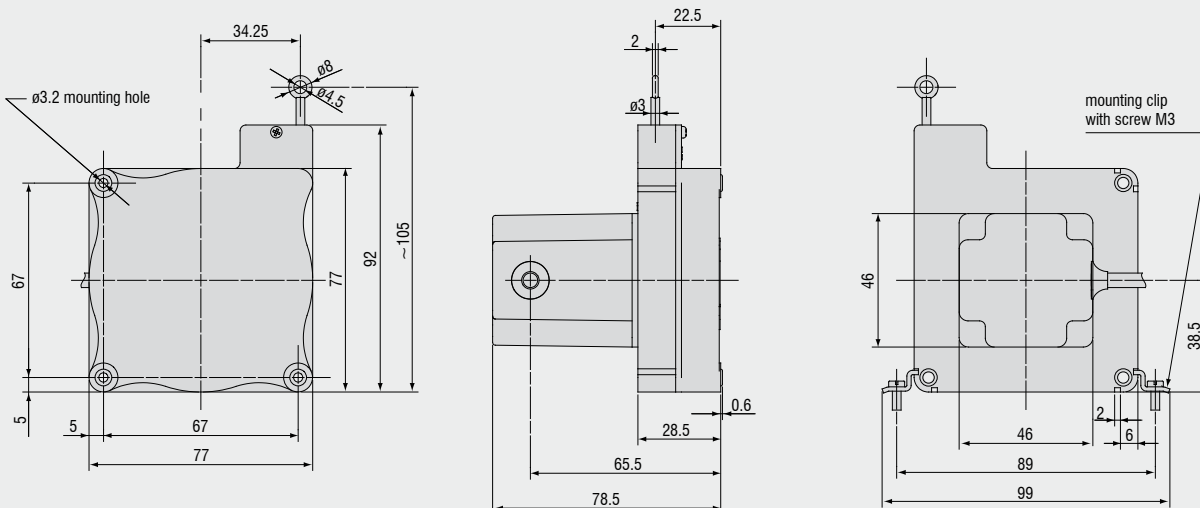

| Model                       |           | WPS-2100-MK77    |                                   |
|-----------------------------|-----------|------------------|-----------------------------------|
| Output                      |           |                  | P25                               |
| Measuring range             |           |                  | 2100mm                            |
| Linearity                   | wire pot. | $\pm 0.25\%$ FSO | 5.25mm                            |
| Resolution                  | wire pot. |                  | 0.55mm                            |
| Sensor element              |           |                  | wire potentiometer                |
| Temperature range           |           |                  | -20 to 80°C                       |
| Material                    | housing   |                  | plastic                           |
|                             | draw wire |                  | coated polyamid stainless steel   |
| Wire mounting               |           |                  | eyelet                            |
| Sensor mounting             |           |                  | mounting holes / mounting grooves |
| Cable diameter              |           |                  | 0.45mm                            |
| Wire retraction force (min) |           |                  | 3.5N                              |
| Wire extension force (max)  |           |                  | 5N                                |
| Wire acceleration           |           |                  | 5g                                |
| Protection class            |           |                  | IP 20                             |
| Electrical connection       | P25       |                  | soldering tag                     |
|                             | CR-P25    |                  | integrated cable radial, 1m       |
| Weight                      | P25       |                  | ca. 0.2kg                         |
|                             | CR-P25    |                  | ca. 0.25kg                        |

FSO = Full Scale Output  
 Specifications for analog outputs on page 47.

#### Article description

##### WPS - 2100 - MK77 - P25

Output option:  
 potentiometer P25 (linearity  $\pm 0.25\%$  FSO)  
 potentiometer CR-P25, integrated cable, radial, 1m

Model MK77

Measuring range in mm



- Robust plastic housing
- Customized versions for OEM
- Incremental/absolute encoder

### Model MK77

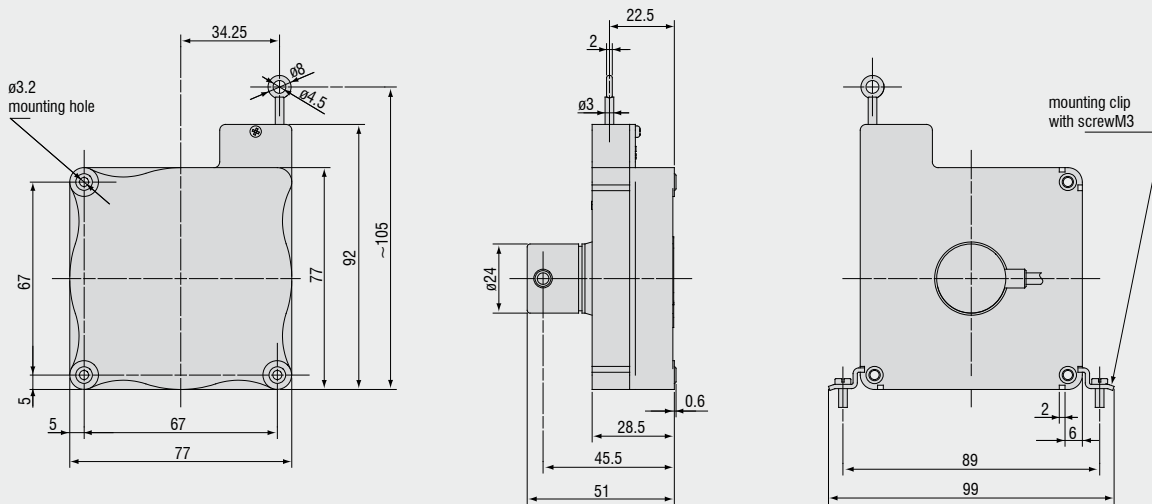

| Model                       | WPS-2100-MK77                     |  |
|-----------------------------|-----------------------------------|--|
| Output                      | E/E830                            |  |
| Measuring range             | 2100mm                            |  |
| Linearity                   | 1.05mm                            |  |
|                             | ±0.05% FSO                        |  |
| Resolution                  | 0.43mm                            |  |
| Sensor element              | incremental encoder               |  |
| Temperature range           | -20 to 80°C                       |  |
| Material                    | housing                           | Plastic                                    |
|                             | draw wire                         | coated polyamid stainless steel (ø 0.45mm) |
| Wire mounting               | Eyelet                            |  |
| Cable diameter              | 0.45mm                            |  |
| Sensor mounting             | mounting holes / mounting grooves |  |
| Wire retraction force (min) | 3.5N                              |  |
| Wire extension force (max)  | 5N                                |  |
| Wire acceleration           | 5g                                |  |
| Protection class            | IP 54                             |  |
| Electrical connection       | cable radial, 2m                  |  |
| Weight                      | appr. 0.27kg                      |  |

FSO = Full Scale Output  
 Specifications for digital outputs on page 48.

#### Article description

**WPS - 2100 - MK77 - E**

Output option:  
 encoder E (5 ... 24VDC)  
 encoder E830 (8 ... 30VDC)

Model MK77

Measuring range in mm

|                           |   |
|---------------------------|---|
| <b>WE-x-M4, WE-x-Clip</b> | Wire extension x=length   |
| <b>TR1-WDS</b>            | Pulley wheel, adjustable  |
| <b>TR3-WDS</b>            | Pulley wheel, fixed   |
| <b>GK1-WDS</b>            | Attachment head for M4  |
| <b>MH1-WDS</b>            | Magnetic holder for wire mounting   |
| <b>MH2-WDS</b>            | Magnetic holder for sensor mounting   |
| <b>MT-60-WDS</b>          | Mounting clamp for WDS-P60  |
| <b>FC8</b>                | Female connector for WDS, 8-pin   |
| <b>FC8/90</b>             | Female connector 90° for WDS  |
| <b>PC 3/8</b>             | Sensor cable, length 3 m  |
| <b>PS 2010</b>            | Power supply (chassis mounting 35 x 7.5 mm);<br>input 120/230 VAC; output 24 VDC/2.5 A;<br>L/B/H 120 x 20 x 40 mm |
| <b>WDS-MP60</b>           | Mounting plate for P60 sensors  |

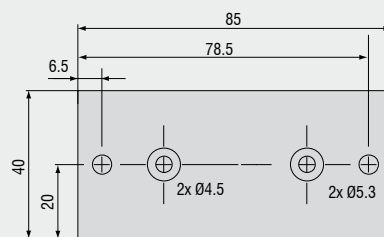
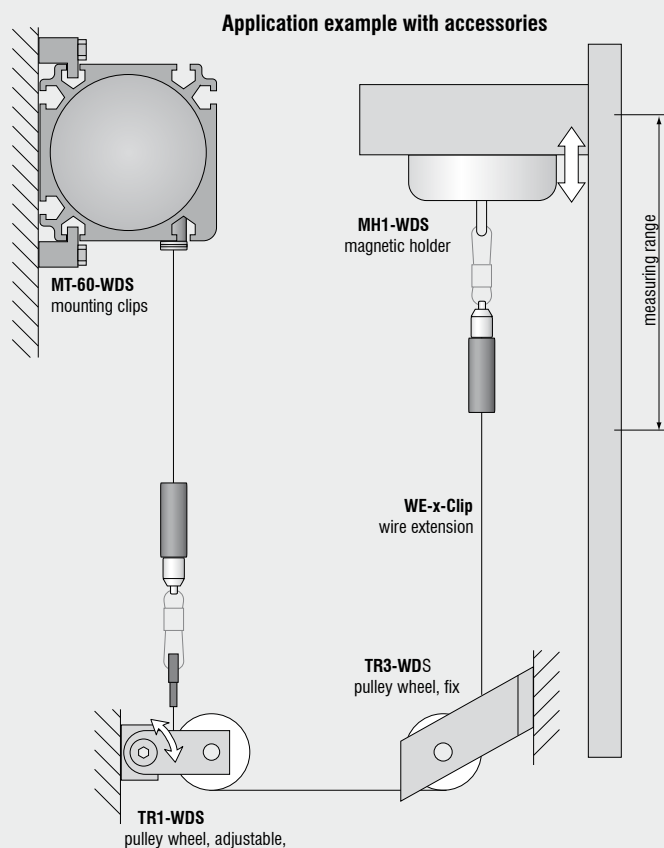

Mounting plate WDS-MP60

**Installation information:**

Wire attachment: The free return of the measurement wire is not permissible and it is essential that this is avoided during installation.

**Wire exit angle:**

When mounting a draw-wire displacement sensor, a straight wire exit ( $\pm 3^\circ$  tolerance) must be taken into account. If this tolerance is exceeded, increased material wear on the wire and at the wire aperture must be expected.

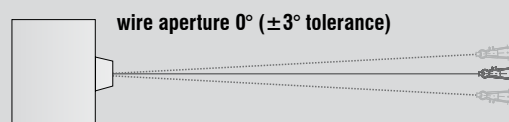

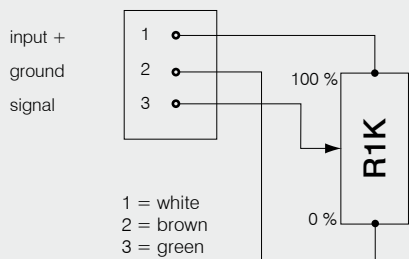

| Potentiometric output (P) |   |
|---------------------------|---|
| Supply voltage            | max. 32VDC at 1kOhm / 1 Wmax                                    |
| Resistance                | 1kOhm ±10% (potentiometer)                                      |
| Temperature coefficient   | ±0.0025% FSO/°C   |
| Sensitivity               | depends on measuring range<br>individually shown on test report |

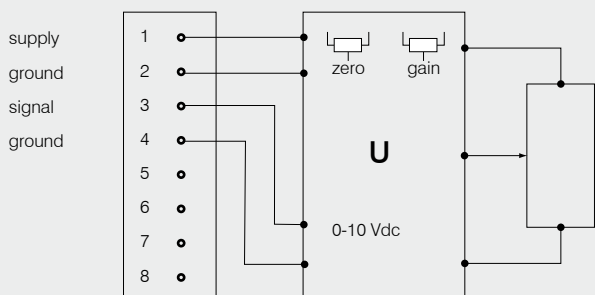

| Voltage output (U)                  |                                     |
|-------------------------------------|-------------------------------------|
| Supply voltage                      | 14 ... 27VDC (non stabilized)       |
| Current consumption                 | 30mA max                            |
| Output voltage                      | 0 ... 10VDC<br>Option 0 ... 5 / ±5V |
| Load impedance                      | >5kOhm                              |
| Signal noise                        | 0.5mV <sub>eff</sub>                |
| Temperature coefficient             | ±0.005% FSO/°C                      |
| Electromagnetic compatibility (EMC) | EN 50081-2<br>EN 50082-2            |
| Adjustment ranges                   |                                     |
| Zero                                | ±20 %FSO                            |
| Sensitivity                         | ±20 %                               |

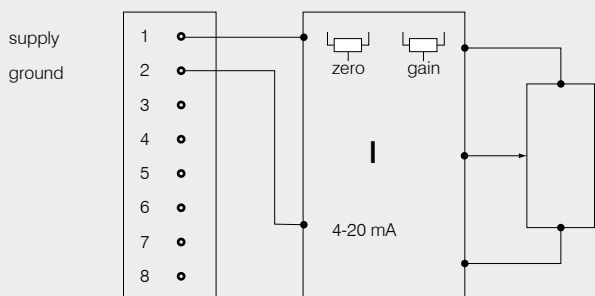

| Current Output (I)                  |                               |
|-------------------------------------|-------------------------------|
| Supply voltage                      | 14 ... 27VDC (non stabilized) |
| Current consumption                 | 35mA max                      |
| Output current                      | 4 ... 20mA                    |
| Load                                | <600Ohm                       |
| Signal noise                        | <1.6µA <sub>eff</sub>         |
| Temperature coefficient             | ±0.01% FSO/°C                 |
| Electromagnetic compatibility (EMC) | EN 50081-2<br>EN 50082-2      |
| Adjustment ranges                   |                               |
| Zero                                | ±18% FSO                      |
| Sensitivity                         | ±15%                          |

## Output specifications SSI

### Contact description

|   |   |
|---|---|
| 1 UB  | Encoder power supply connection.  |
| 2 GND   | Encoder ground connection. The voltage drawn to GND is UB.  |
| 3 Pulses +  | Positive SSI pulse input. Pulse + forms a current loop with pulse -. A current of approx. 7 mA in direction of pulse + input generates a logical 1 in positive logic.   |
| 4 Data +  | Positive, serial data output of the differential line driver. A High level at the output corresponds to logical 1 in positive logic.  |
| 5 ZERO  | Zero setting input for setting a zero point at any desired point within the entire resolution. The zeroing process is triggered by a High pulse (pulse duration $\geq 100$ ms) and must take place after the rotating direction selection (UP/DOWN). For maximum interference immunity, the input must be connected to GND after zeroing.   |
| 6 Data -  | Negative, serial data output of the differential line driver. A High level at the output corresponds to logical 0 in positive logic.  |
| 7 Pulses -  | Negative SSI pulse input. Pulse - forms a current loop with pulse +. A current of approx. 7 mA in direction of pulse - input generates a logical 0 in positive logic.   |
| 8 / 10<br>$\overline{\text{DATAVALID}}$<br>$\overline{\text{DATAVALID MT}}$ | Diagnosis outputs $\overline{\text{DV}}$ and $\overline{\text{DV MT}}$ Jumps in data word, e.g. due to defective LED or photoreceiver, are displayed via the $\overline{\text{DV}}$ output. In addition, the power supply of the multiturn sensor unit is monitored and the $\overline{\text{DV MT}}$ output is set when a specified voltage level is dropped below. Both outputs are Low-active, i.e. are switched through to GND in the case of an error. |
| 9 UP/DOWN   | UP/DOWN counting direction input. When not connected, this input is on High. UP/ $\overline{\text{DOWN}}$ -High means increasing output data with a clockwise shaft rotating direction when looking at the flange. UP/ $\overline{\text{DOWN}}$ -Low means increasing values with a counter-clockwise shaft rotating direction when looking at the flange.  |
| 11 / 12   | Not in use  |

### Anschlussbelegung

| Pin | Cable color  | Assignment                       |
|-----|--------------|----------------------------------|
| 1   | brown        | UB                               |
| 2   | black        | GND                              |
| 3   | blue         | Pulses +                         |
| 4   | beige        | Data +                           |
| 5   | green        | ZERO                             |
| 6   | yellow       | Data -                           |
| 7   | violet       | Pulses -                         |
| 8   | brown/yellow | $\overline{\text{DATAVALID}}$    |
| 9   | pink         | UP/ $\overline{\text{DOWN}}$     |
| 10  | black/yellow | $\overline{\text{DATAVALID MT}}$ |
| 11  | -            | -                                |
| 12  | -            | -                                |

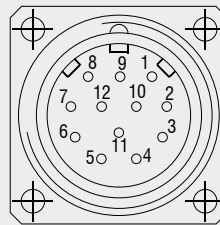

Please use leads twisted in pairs for extension cables.

### Inputs

Control signals UP/DOWN and Zero

|            |         |
|------------|---------|
| Level High | > 0.7UB |
| Level Low  | < 0.3UB |

Connection: UP/DOWN input with 10kohms to UB, zeroing input with 10kohms to GND.

SSI pulse

Optocoupler inputs for electrical isolation

### Outputs

|   |                             |
|---|-----------------------------|
| SSI data                                  | RS485 driver                |
| Diagnostic outputs                        |                             |
| Push-pull outputs are short-circuit-proof |                             |
| Level High                                | > UB -3.5V (with I = -20mA) |
| Level Low                                 | $\leq 0.5V$ (with I = 20mA) |



## CANopen features

|                                   |  |
|-----------------------------------|--|
| Bus protocol                      | CANopen  |
| Device profile                    | CANopen - CiA DSP 406, V 3.0   |
| CANopen Features                  | Device Class 2, CAN 2.0B   |
| Operating modes (with SDO progr.) | <p>Polling Mode (asynch, via SDO)</p> <p>Cyclic Mode (asynch-cyclic) The encoder cyclically sends the current process actual value without a request by a master. The cycle time can be parameterized for values between 1 and 65535 ms. Synch Mode (synch-cyclic) The encoder sends the current actual process value after receiving a synch telegram sent by a master. The synch counter in the encoder can be parameterized so that the position value is not sent until after a defined number of synch telegrams.</p> <p>Acyclic Mode (synch-acyclic)</p> |
| Preset value                      | With the "Preset" parameter the encoder can be set to a desired actual process value that corresponds to the defined axis position of the system. The offset value between the encoder zero point and the mechanical zero point of the system is saved in the encoder.   |
| Rotating direction                | With the operating parameter the rotating direction in which the output code is to increase or decrease can be parameterized. Scaling The steps per revolution and the total revolution can be parameterized.  |
| Scaling:                          | The steps per revolution and the total revolution can be parameterized.  |
| Diagnose                          | <p>The encoder supports the following error messages:</p> <ul style="list-style-type: none"> <li>- Position and parameter error</li> <li>- Lithium cell voltage at lower limit (Multiturn)</li> </ul>  |
| Default setting                   | 50kbit/s, node number 1  |

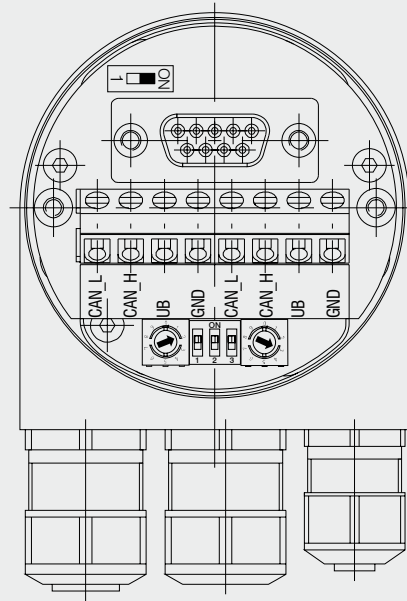

Setting of terminating Resistor for CANopen



ON = Last user  
OFF = User X

## Setting CANopen baud rate

| Baud rate | Setting Dip Switch |     |     |
|-----------|--------------------|-----|-----|
|           | 1                  | 2   | 3   |
| 10kBit/s  | OFF                | OFF | OFF |
| 20kBit/s  | OFF                | OFF | ON  |
| 50kBit/s  | OFF                | ON  | OFF |
| 125kBit/s | OFF                | ON  | ON  |
| 250kBit/s | ON                 | OFF | OFF |
| 500kBit/s | ON                 | OFF | ON  |
| 800kBit/s | ON                 | ON  | OFF |
| 1MBit/s   | ON                 | ON  | ON  |

## Contact description CANopen

|       |                                |
|-------|--------------------------------|
| CAN_L | CAN Bus Signal (dominant Low)  |
| CAN_H | CAN Bus Signal (dominant High) |
| UB    | Versorgungsspannung 10...30VDC |
| GND   | Ground contact for UB          |

(Terminals with the same designation are internally interconnected)

## Settings of user address for CANopen

Address can be set with rotary switch. Example: User address 23

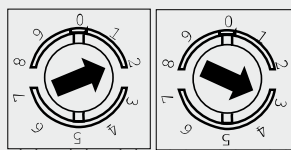

## Output specifications Profibus

### Profibus-DP features

|                      |  |
|----------------------|--|
| Bus protocol         | Profibus-DP  |
| Profibus features    | Device Class 1 and 2   |
| Data exch. functions | Input: Position value<br>Additional parameterized speed signal (readout of the current rotary speed)<br>Output: Preset value                       |
| Preset value         | With the "Preset" parameter the encoder can be set to a desired actual value that corresponds to the defined axis position of the system.          |
| Parameter functions  | Rotating direction: With the operating parameter the rotating direction for which the output code is to increase or decrease can be parameterized. |
| Diagnose             | The encoder supports the following error messages:<br>- Position error<br>- Lithium cell voltage at lower limit (Multiturn)                        |
| Default setting      | User address 00  |

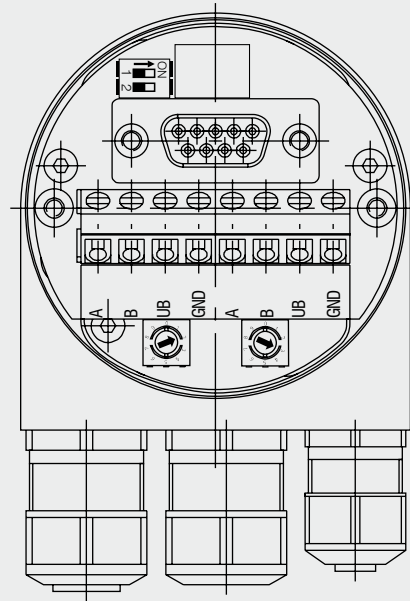

Settings of terminating resistors for Profibus-DP



ON = last user  
OFF = user X

### Settings of user address for Profibus-DP

Address can be set with rotary switch. Example: User address 23

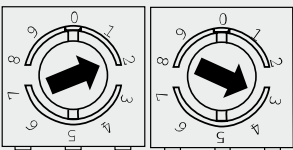

### Contact description Profibus-DP

|     |                             |
|-----|-----------------------------|
| A   | A negative serial data line |
| B   | Positive serial data line   |
| UB  | Supply voltage 10...30VDC   |
| GND | Ground contact for UB       |

(Terminals with the same designation are internally interconnected)

## Signal output

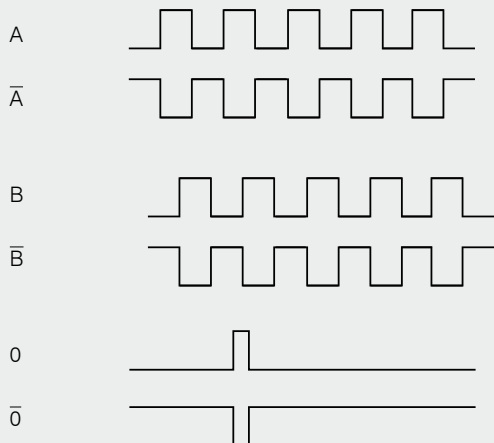

| Output TTL | Linedriver (5VDC)               |
|------------|---------------------------------|
| Level High | $\geq 2.5V$ (with $I = -20mA$ ) |
| Level Low  | $\leq 0.5V$ (with $I = 20mA$ )  |
| Load High  | $\leq 20mA$                     |
| Output     | A, $\bar{A}$ , B, $\bar{B}$ , O |

| Output HTL | Push-pull (10 ... 30VDC)          |
|------------|-----------------------------------|
| Level High | $\geq UB -3V$ (with $I = -20mA$ ) |
| Level Low  | $\leq 1.5V$ (with $I = 20mA$ )    |
| Load High  | $\leq 40mA$                       |
| Output     | A, $\bar{A}$ , B, $\bar{B}$ , O   |

| Output E   | Push-pull (5VDC) |
|------------|------------------|
| Level High | UB -2.5V         |
| Level Low  | $\leq 0.5V$      |
| Load High  | $\leq 50mA$      |
| Output     | A, B, O          |

| Output E830 | Push-pull (8 ... 30VDC) |
|-------------|-------------------------|
| Level High  | UB -3V                  |
| Level Low   | $\leq 2.5V$             |
| Load High   | $\leq 50mA$             |
| Output      | A, B, O                 |

## Pin assignment TTL, HTL

| Pin | Cable color | Assignment                 |
|-----|-------------|----------------------------|
| 1   | pink        | B inv.                     |
| 2   | blue        | UB Sense                   |
| 3   | red         | N (Nullimpulses)           |
| 4   | black       | N inv. (Nullimpulses inv.) |
| 5   | brown       | A                          |
| 6   | green       | A inv.                     |
| 7   | -           | -                          |
| 8   | grey        | B                          |
| 9   | -           | -                          |
| 10  | white/green | GND                        |
| 11  | white       | GND Sense                  |
| 12  | brown/green | UB                         |

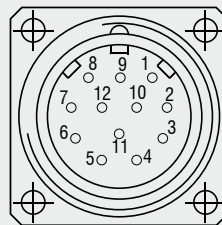

Pin 2 and Pin 12 are internally connected as well as Pin 11 and 10.  
For cable length >10m twisted pair wires are required.

## Connection assignment E, E830

| Pin | Cable color | Assignment |
|-----|-------------|------------|
| -   | white       | 0V         |
| -   | brown       | +UB        |
| -   | green       | A          |
| -   | -           | $\bar{A}$  |
| -   | yellow      | B          |
| -   | -           | $\bar{B}$  |
| -   | grey        | O          |

## High performance sensors made by Micro-Epsilon



Sensors and systems for displacement and position

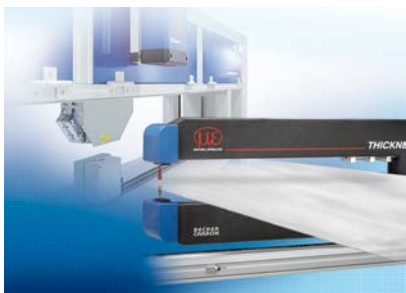

Measurement and inspection systems for quality assurance



Sensors and measurement devices for non-contact temperature measurement



Optical micrometers, fibre optic sensors and fibre optics



2D/3D profile sensors (laser scanner)



Colour recognition sensors, LED analyzers and colour online spectrometer



MICRO-EPSILON Headquarters  
Koenigbacher Str. 15 · 94496 Ortenburg / Germany  
Tel. +49 (0) 8542 / 168-0 · Fax +49 (0) 8542 / 168-90  
info@micro-epsilon.com · www.micro-epsilon.com

MICRO-EPSILON UK Ltd.  
No.1 Shorelines Building · Shore Road · Birkenhead · CH41 1AU  
Phone +44 (0) 151 355 6070 · Fax +44 (0) 151 355 6075  
info@micro-epsilon.co.uk · www.micro-epsilon.co.uk